

Standards of Power Quality with reference to the Code of Practice for Energy Efficiency of Electrical Installations

Ir. Martin WU Kwok-tin,

Energy Efficiency Office, Electrical & Mechanical Services Department
September 2003

Abstract

The Code of Practice for Energy Efficiency of Electrical Installations (Electrical Energy Code) developed under a dedicated Task Force of the Energy Advisory Committee (EnAC) was completed in May 1998. The Electrical Energy Code forms part of the comprehensive building energy codes established for Hong Kong. The Code sets out the minimum requirements to achieve energy efficiency design for electrical installations on distribution losses, utilisation losses, power quality, metering facilities, etc. The main objectives of the Electrical Energy Code are as follows:

- to enhance energy efficiency in electrical installation design for buildings;
- to reduce losses, conserve energy, save money and minimise impact to local and global environment;
- to complement existing safety standards; and
- to supplement requirements of other Energy Codes (e.g. A/C, Lighting and Lift & Escalator) and help to improve power quality.

This paper focuses on the energy issues in relation to the power quality problems in the power distribution systems of buildings and describes the proposed standards and requirements of power quality as set out in the Electrical Energy Code.

1. Introduction

The Electrical Energy Code applies to all fixed electrical installations for all types of buildings except, emergency systems, small domestic houses, buildings with total installed capacity of 100A or less, single or three phases, at nominal low voltage, and buildings used solely for public utility services.

The general approaches used for the Electrical Energy Code are as follows:

- a) To set out the minimum requirements for achieving energy efficient design of electrical installations in buildings without sacrificing the relevant safety and health regulations.
- b) To minimise copper losses in the complete power distribution systems in buildings.
- c) To reduce equipment losses and energy wastage in the utilisation of electrical energy.
- d) To reduce all associate losses and inefficient use of electrical energy related to power quality problems in buildings.
- e) To introduce appropriate metering and monitoring facilities to carry out future energy audit and building management works.

As far as energy efficiency is concerned in a building power distribution system, the two dominant factors in power quality are its harmonic distortion and unbalanced distortion. Harmonic currents will generate additional heat in conductors due to skin and proximity

effects, causing accelerated cable ageing and insulation breakdown. Unbalanced distortion in three-phase supply voltages will create negative sequence component causing additional power losses in conductors and motors. Both distortions will add undesirable currents and voltage drop in neutral conductors.

2. Harmonic Distortion

2.1 Requirements for Maximum Total Harmonic Distortion (THD) of Current

Clause 6.1 of the Code requires that the total harmonic distortion (THD) of current for any circuit should not exceed the appropriate figures in Table 6.1. According to the quantity and nature of the known non-linear equipment to be installed in the building, design calculations are required to demonstrate sufficient provision of appropriate harmonic reduction devices to restrict harmonic currents of the non-linear loads at the harmonic sources, such that the maximum THD of circuit currents, at rated load conditions, shall be limited to those figures as shown in Table 6.1 below.

Table 6.1: Maximum THD of current in percentage of fundamental

Circuit Current at Rated Load Condition ' I at 380V/220V	Maximum Total Harmonic Distortion (THD) of Current
$I < 40A$	20.0%
$40A \leq I < 400A$	15.0%
$400A \leq I < 800A$	12.0%
$800A \leq I < 2000A$	8.0%
$I \geq 2000A$	5.0%

In case of motor circuits using Variable Speed Drives (VSD), group compensation at the sub-main panel or Motor Control Centre (MCC) is allowed, provided that the maximum allowable fifth harmonic current distortion at the VSD input terminals during operation within the variable speed range is less than 35%.

If the quantity and nature of non-linear equipment to be installed in the building cannot be assessed initially, appropriate harmonic reduction devices shall be provided at a later date after occupation.

2.2 Harmonic-Related Loss Mechanisms in Power Wiring

The problems associated with the present of harmonics on power distribution systems are not just the power quality problems but also affect the energy efficiency of the system. Typical problems include overheating transformers, motors, phase and neutral conductors, causing unacceptable neutral-to-earth voltage, voltage distortion, electromagnetic interference (EMI), capacitor bank failure, etc.

Many of the problems are related to the proliferation of non-linear loads such as variable speed motor drives, rectifiers for direct-current power supplies, electronic ballasts in energy efficient lighting and switch-mode power supplies in computers and other electronic office equipment.

Figure 1 below shows a typical current waveform of a personal computer with a total current harmonic distortion of 130%.

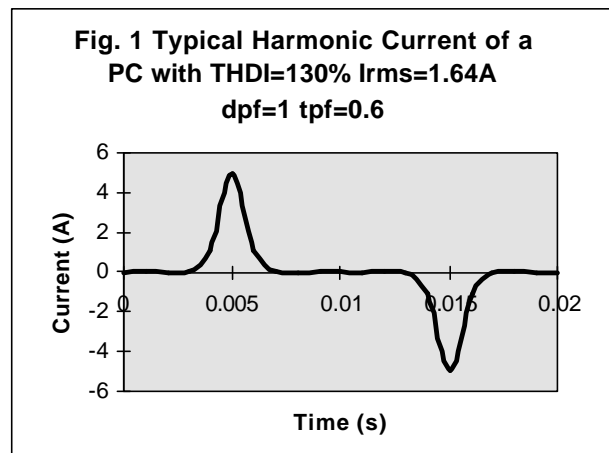
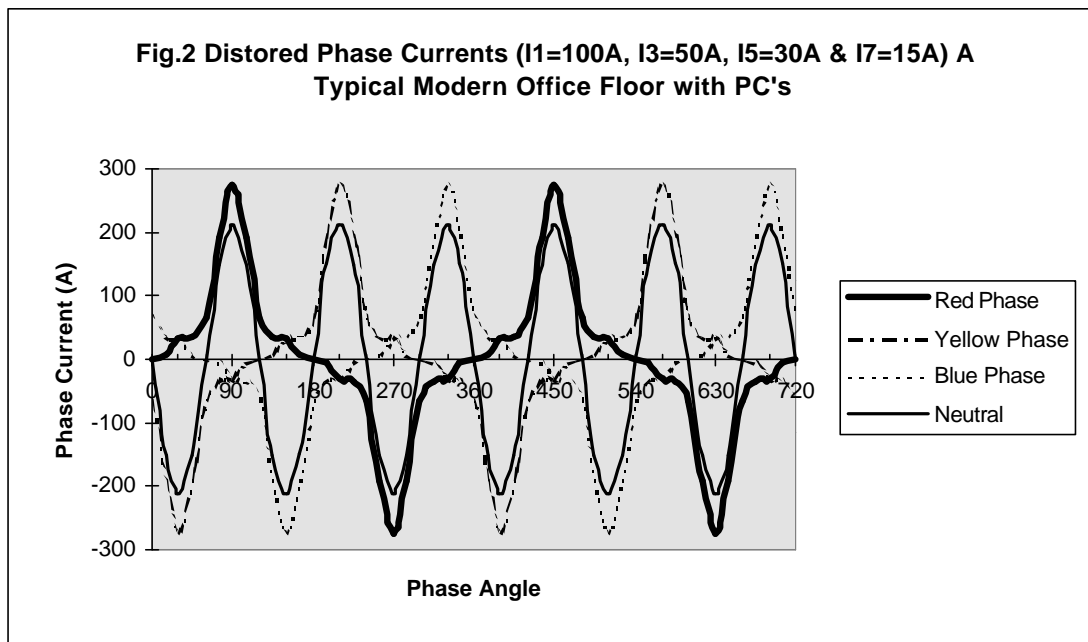

Figure 2 shows a 3-phase 4-wire small power distribution system for a typical modern office floor with personal computers and other office machinery. It is noted that the system consists of large triplen harmonic currents and high neutral current.



Another example is the installations of compact fluorescent luminaires with integrated electronic ballasts or linear fluorescent lamps with low-cost electronic ballasts (i.e. old design without effective harmonic filters). Figure 3 shows a typical waveform of one phase and neutral currents of such lighting installations.

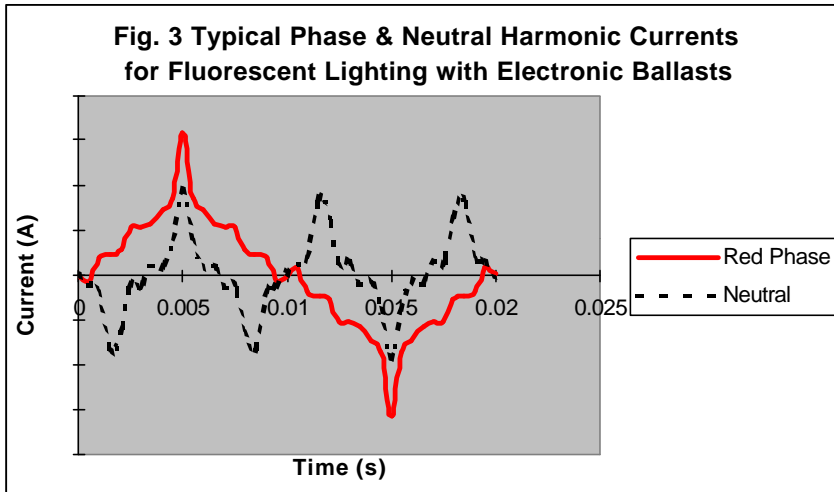
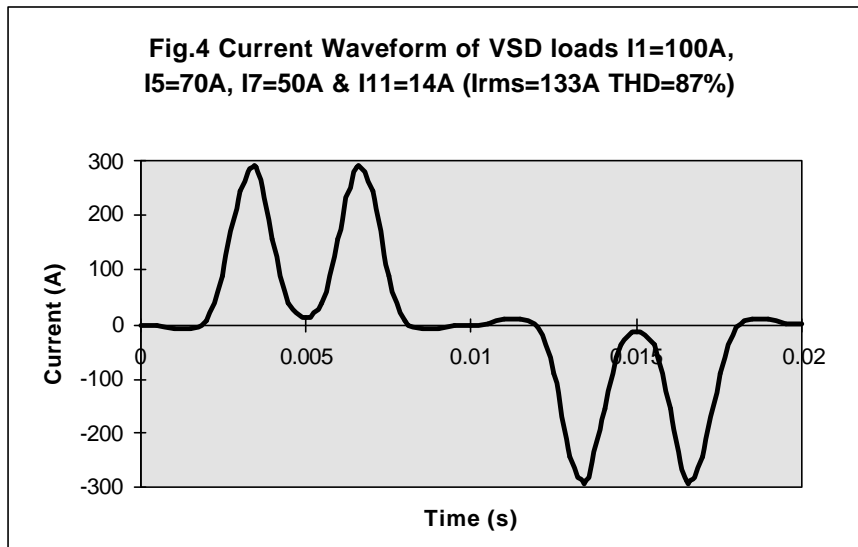

Figure 4 shows the current waveform of one phase of a typical variable speed drive system using pulse width modulation (PWM) type inverter. The total harmonic distortion is very high and is well over 80%.



Electronic equipment nowadays tends to be distributed in the building on various final circuits and socket outlets rather than centralised in one area as in a computer room where special power provisions (e.g. UPS system) are made. Most of the losses associated with harmonics are in the building wiring circuits. Harmonic distortion is serious at the terminals of the non-linear loads, but tends to be diluted when combined with linear loads at points upstream in the system.

The total harmonic distortion (THD) is defined by

$$THD = \frac{\sqrt{\sum_{h=2}^{\infty} (I_h)^2}}{I_1} \quad (1)$$

where I_h is the rms current of the h^{th} harmonic current, and I_1 is the rms value of the fundamental current. A typical supply voltage waveform at a consumer's metering point (or point of common coupling) normally doesn't exceed 5% THD in Hong Kong but for some high-rise commercial buildings, the voltage THD exceeding 10% is not uncommon especially at those higher level floors fed with a common rising mains. The third harmonic is normally the most prominent component (zero sequence), resulting in high neutral current flow in the neutral conductors of a power distribution system. The adverse effects of high neutral current will be addition energy losses, overcurrent and additional voltage drop causing undesirable high neutral to earth voltage and low phase to neutral voltage.

For electronic appliances that are retrofitted to comply with the other energy codes and save energy, such as electronic ballasts, VSDs, VVVF lift drive system etc., an important point needs to be considered is how much of the energy savings must not be diminished by added harmonic losses in the power system.

2.2.1 Cables

The only cable power loss component is I^2R , where I could be increased by the harmonic distortion, and the R value is determined by its dc value plus ac skin and proximity effects. The rms value including harmonic currents is defined by:

$$I = \sqrt{\sum_{h=1}^{\infty} I_h^2} = \sqrt{I_1^2 + I_2^2 + I_3^2 + \dots} \quad (2)$$

Manipulating (1) and (2) yields the total rms current in

$$I = I_1 \sqrt{1 + THD^2} \quad (3)$$

Equation (3) indicates that, without harmonics, the total rms current is simply the value of the fundamental component. For the above PC example, with 130% THD, the total current is nearly 64% higher than the fundamental current.

Taking into account the frequency-related effects, a ratio of ac to dc resistance, k_c , can be defined as

$$k_c = \frac{R_{ac}}{R_{dc}} = 1 + y_s + y_p \quad (4)$$

Where y_s is the resistance gain due to skin effect, and y_p is the resistance gain due to proximity effect.

The resistance gain due to skin and proximity effects for multicore cables, as a function of frequency, conductor diameter and spacing of cores, can be assessed from the formula and information given in IEC287-1-1 "Current rating equations and calculation of losses".

Consider three different sized cables: 10mm², 150mm² and 400mm² 4-core PVC/SWA/PVC cables, typically used in a building power distribution system. Their ac/dc resistance ratios at different frequencies can be calculated according to IEC287-1-1 shown in Fig. 5 below. Series 1, 2 and 3 indicate the variation of resistance with frequencies for 10mm² cable, 150mm² cable and 400mm² cable respectively. It is noted that for smaller-sized cable, the effects of skin and proximity is small for the 3rd and 5th harmonics which are normally dominated in the power distribution system of a building.

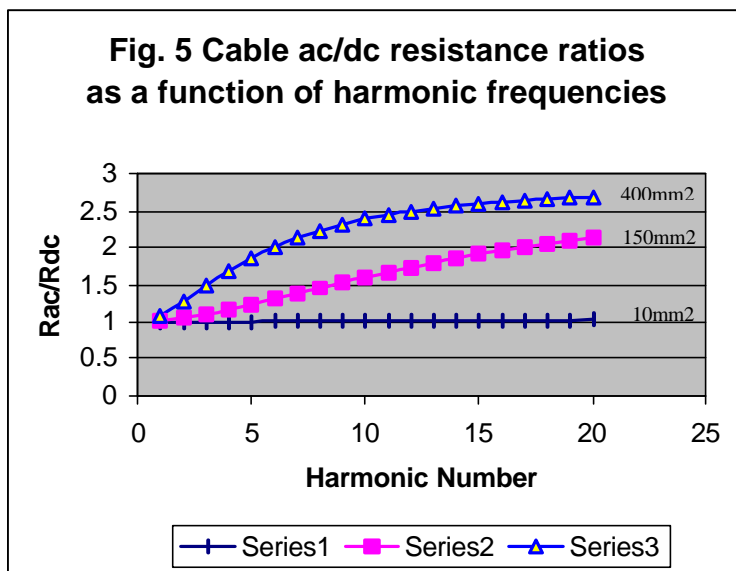

2.2.2 Transformers

Most of the distribution transformers in Hong Kong are provided by the two power supply companies and all these transformer losses are therefore absorbed by the power companies. Harmonics produce extra losses in transformers and these costs could not be recovered from their consumers. Both CLP and HEC have been considering to specify requirements that the consumer must comply with in order to limit the magnitudes of harmonic distortion at the consumer's metering point.

Transformer loss components include no-load (P_{NL}) and load-related loss (P_{LL}). The load loss, as a function of load current, can be divided into I^2R (P_R) loss and stray losses. The stray losses are caused by eddy-currents that produce stray electromagnetic flux in the windings, core, core clamps, magnetic shield and other parts of the transformer. For harmonic-rich currents, the eddy-current loss (P_{EC}) in the windings is the most dominant loss component.

$$P_{Loss} = P_{NL} + P_R + P_{EC} \quad (5)$$

For non-linear load currents, the total rms current can be obtained by (2) and (3), and the power loss can be obtained by the sum of the squares of the fundamental and harmonic currents, as shown in (6)

$$P_R = \sum_{h=1}^{\infty} I_h^2 R_h \quad (6)$$

The winding eddy current loss in transformers increases proportional to the square of the product of harmonic current and its corresponding frequency. Given the winding eddy current

loss at the fundamental frequency as P_{ECI} , the approximate total eddy current losses including harmonic frequency components can be calculated by

$$P_{EC} = P_{ECI} \sum_{h=1}^{\infty} I_h^2 h^2 \quad (7)$$

2.3 Other Electrical Equipment in the Building

Other equipment that may be affected by harmonics includes protective devices, computers, motors, capacitors, reactors, relays, metering instrument, emergency generators, etc. The major harmonic effects to these equipment include performance degradation, increased losses and heating, reduced life, and possible resonance. For motor and relays, the primary loss mechanism is the negative sequence harmonic voltage (e.g. 5th and 11th order) that is present at the terminals of the equipment.

3. Unbalanced Distortion

3.1 Requirement for Unbalanced Distortion

Clause 6.2 of the Electrical Energy Code requests that all single-phase loads, especially those with non-linear characteristics, in an electrical installation with a three-phase supply should be evenly and reasonably distributed among the phases. Such provisions are required to be demonstrated in the design for all three-phase 4-wire circuits exceeding 100A with single-phase loads.

The maximum unbalanced single-phase load distribution, in term of percentage current unbalance shall not exceed 10%. The percentage current unbalance can be determined by the following expression:

$$I_u = (I_d \times 100) / I_a \quad (8)$$

Where I_u = percentage current unbalance

I_d = maximum current deviation from the average current

I_a = average current among three phases

3.2 Effect on Neutral Conductors

The connection of single-phase loads of different characteristics and power consumption to the three-phase power supply system will result in unequal currents flowing in the three-phase power circuits and unbalanced phase voltages at the power supply point, i.e. unbalanced distortion.

The adverse effects of unbalanced distortion on the power distribution system include:

- i) addition power losses and voltage drop in the neutral conductors
- ii) causing unbalanced 3-phase voltages in the power distribution system
- iii) reduced forward operating torque and overheating of induction motors
- iv) excessive electromagnetic interference (EMI) to sensitive equipment in buildings
- v) additional error in power system measurement

All single-phase loads are potential sources of unbalanced distortion. They should be carefully planned at design stage for balancing, even though the random connection and operation of large number of small rating single-phase loads on the final circuits will tend to cancel their unbalance distortion effect in the main and sub-main circuits.

A 10% unbalanced phase current in a 3-phase 4-wire power distribution system with an average phase current of 100A (Fig. 6) would produce a neutral current of about 17A and increase the total copper loss by about 1%. The combination effect of 10% unbalanced and 30% THD phase currents (Fig. 7) on the same circuit would produce a neutral current almost the same magnitude as the phase current resulting in much higher losses in a 3-phase 4-wire power distribution system.

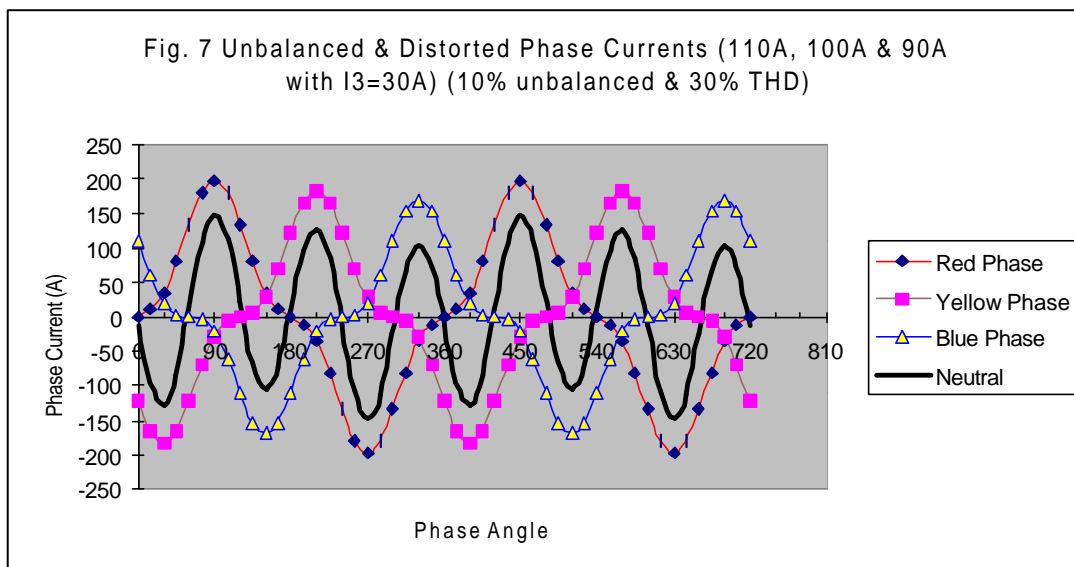
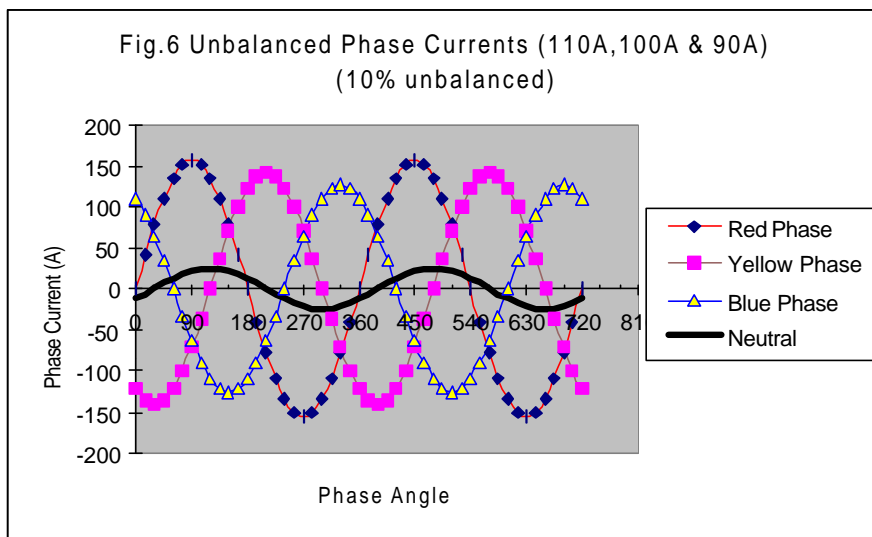

3.3 Effect on AC Motor Operation

Voltage level variation and unbalanced voltage caused by unbalanced distortion of single-phase loads are some of the voltage deviations which can affect motor operating cost and reliability. The published 3-phase induction motor characteristics are based on perfect

balanced voltages between phases. Overheating (additional loss) and reduction in output torque are serious ill effects caused by operation of induction motors on unbalanced voltages. The magnitude of these ill effects is directly related to the degree of voltage unbalance.

The adverse effects of unbalanced voltage on 3-phase induction motor operation come from the fact that the unbalanced voltage break down into the positive sequence component and the opposing negative sequence component.

The positive sequence component produces the wanted positive torque. This torque is generally of less magnitude than the normal torque output from a balanced voltage supply and with somewhat higher than normal motor losses, because the positive sequence voltage is usually lower than rated voltage. The negative sequence component produces a negative torque which is not required. All the motor power that produces this torque goes directly into the loss that must be absorbed by the motor. By increasing the amount of unbalanced voltage, the positive sequence voltage decreases and the negative sequence voltage increases. Both of these changes are detrimental to the successful operation of motor. Positive (E_{+ve}) and negative (E_{-ve}) sequence voltages can be calculated by the symmetrical components relationship as (9) and (10)

$$E_{+ve} = \frac{1}{3}(E_R + aE_Y + a^2E_B) \quad (9)$$

$$E_{-ve} = \frac{1}{3}(E_R + a^2E_Y + aE_B) \quad (10)$$

Where E_R , E_Y and E_B are the original unbalanced voltages for red, yellow and blue phases and $a = -1/2 + j\sqrt{3}/2$.

The application of negative sequence voltage to the terminal of a 3-phase machine produces a flux which rotates in the opposite direction to that produced by positive sequence voltage. Thus, at synchronous speed, voltages and currents are induced in the rotor at twice the line frequency. The application of negative sequence voltage can therefore affect torque, stator and rotor copper losses, rotor iron losses and consequently machine overheating. It is interesting to note that harmonic voltages of the 5th, 11th, 17th, etc. order are also negative sequence and would produce similar adverse effect as unbalanced voltages.

4. Requirements for Metering & Monitoring Facilities

The last category of requirement of the Electrical Energy Code is the metering and monitoring of various electrical characteristics and energy consumption to facilitate future work on energy audit and building management.

The first requirement is that all main circuits exceeding 400A rating must be incorporated with meters or metering facilities to measure all voltages, currents including neutral, power factor, maximum demand in kVA and energy consumption in kWh.

The other requirement is that all sub-main distribution and dedicated feeder circuits exceeding 200A rating must be complete with meters or metering facilities to measure phase and neutral currents and energy consumption.

The advanced power monitoring instrument available nowadays can be used for metering, power quality analysis, energy management and supervisory control for power distribution systems. The instrument can be linked into the building management system of the building as one element in an energy management network. Selection for applying the most beneficial tariff system could also be analysed by the instrument from the logged data of energy consumption and load profile of the building.

5. Methodology for Energy Efficient Design of Circuits with Harmonics

5.1 Conventional Cable Sizing Procedure

The majority of electrical engineers base their design and specification calculations on the assumption that the voltages and currents in power distribution systems are sinusoidal and perfectly balanced.

For conventional cable sizing method, the relationship among circuit design current (I_b), nominal rating of protective device (I_n) and effective current-carrying capacity of conductor (I_z) for an electrical circuit can be expressed as follows:

Co-ordination among I_b , I_n & I_z : $I_b \leq I_n \leq I_z$

Calculated minimum tabulated value of current : $I_{t(min)} = I_n \times \frac{1}{C_a} \times \frac{1}{C_g} \times \frac{1}{C_i}$

Effective current-carrying capacity : $I_z = I_t \times C_a \times C_g \times C_i$

where I_t = the value of current tabulated in Appendix 4 of BS7671:1992 - The Regulations for Electrical Installations

C_a = Correction factor for ambient temperature

C_g = Correction factor for grouping

C_i = Correction factor for thermal insulation

This conventional cable sizing technique needs co-ordination among the design current, nominal rating of a protective device and the effective current-carrying capacity of conductors of a circuit. All relevant correction factors, such as grouping, ambient temperature, thermal insulation, etc. should then be applied to determine an appropriate cable sizing of a circuit to fulfil the safety requirement.

Although the correction factors applied in cable sizing have the effect of using larger cable size and eventually reduce the copper loss, the actual calculation work to fulfil both safety and energy requirements are very tedious. In order to simplify the calculation work, a second approach based on the maximum conductor resistance could be used instead.

5.2 Energy Efficient Method for Cable Sizing

This energy efficiency method for cable sizing requires the calculation of the maximum allowable conductor resistance based on the maximum copper loss requirement as stipulated in the code.

For a 3-phase 4-wire circuit (assuming balanced, linear or non-linear):

Active power transmitted via the circuit conductors, $P = \sqrt{3}U_L I_1 \cos\phi$

Total copper losses in conductors, $P_{copper} = (3 \times I_b^2 + I_n^2) \times r \times L$

where U_L = Line to line voltage, 380V

I_b = Design current of the circuit in ampere

I_1 = Fundamental current of the circuit in ampere

I_n = Neutral current of the circuit in ampere

$\cos \mathbf{q}$ = Displacement power factor of the circuit

r = a.c. resistance / conductor / metre at the conductor operating temperature

L = Length of the cable in metre

Percentage copper loss with respect to the total active power transmitted,

$$\% \text{ copper loss} = \frac{(3 \times I_b^2 + I_n^2) \times r \times L}{P} \times 100 = \frac{(\sum I^2) \times r \times L}{P} \times 100$$

$$\text{Therefore, max. } r \text{ (m}\Omega\text{/m)} = \frac{\text{max. \% loss} \times P \times 1000}{(\sum I^2) \times L}$$

Table 4.2A and 4.2B in the draft code provide a quick initial assessment of cable size required for the common cable types and installation methods used in Hong Kong.

The tabulated current rating of the selected cable could then be corrected by applying the correction factors accordingly. The effective-current carrying capacity of the selected cable must be checked so that its value is larger than or equal to the nominal rating of the circuit protective device. Computer programmes could be used to release designers on the tedious task of cable sizing using the energy efficient method.

5.3 Total and Displacement Power Factor

Consider a circuit with non linear loads current I , which is the rms values of fundamental (I_1) and all harmonic components (I_2, I_3, I_4, \dots), an expression of the power factor could be found as follows, assuming the circuit is fed from a line voltage having a low value of distortion and only the fundamental sinusoidal value U_1 is significant:

$$\begin{aligned} \text{Apparent Power: } S &= UI \\ S^2 &= (UI)^2 = U_1^2 (I_1^2 + I_2^2 + I_3^2 + I_4^2 + \dots) \\ &= U_1^2 I_1^2 \cos^2 \mathbf{q} + U_1^2 I_1^2 \sin^2 \mathbf{q} + U_1^2 (I_2^2 + I_3^2 + I_4^2 + \dots) \end{aligned}$$

According to this expression in the distorted circuit, the apparent power contained three major components:

1. Active Power in kW $P = U_1 I_1 \cos \mathbf{q}$
(This is the effective useful/active power)
2. Reactive Power in kvar $Q_1 = U_1 I_1 \sin \mathbf{q}$
(This is the fluctuating power due to the fundamental component and coincides with the conventional concept of reactive power in an inductive circuit consumed and returned to the network during the creation of magnetic fields)

- Distortion Power in kvad $D^2 = U_1^2 \cdot (I_2^2 + I_3^2 + I_4^2 + \dots)$
(This power appears only in distorted circuits and its physical meaning is that of a fluctuating power due to the presence of harmonic currents)

The relationship among these three power components could further be shown in the following power triangles:

- Fundamental Components: $S_1^2 = P^2 + Q_1^2$
(Note: Displacement Power Factor, $\cos \mathbf{q} = P/S_1$)
- Fluctuating Power: $Q_T^2 = Q_1^2 + D^2$
- Power Triangle in Distorted Circuit: $S^2 = Q_T^2 + P^2$
(Note: Total Power Factor, $\cos \mathbf{g} = P/S$, is always smaller than the Displacement Power Factor, $\cos \mathbf{q}$ and could be improved by either reducing the amount of harmonic distortion power (kvad) or reactive power (kvar))

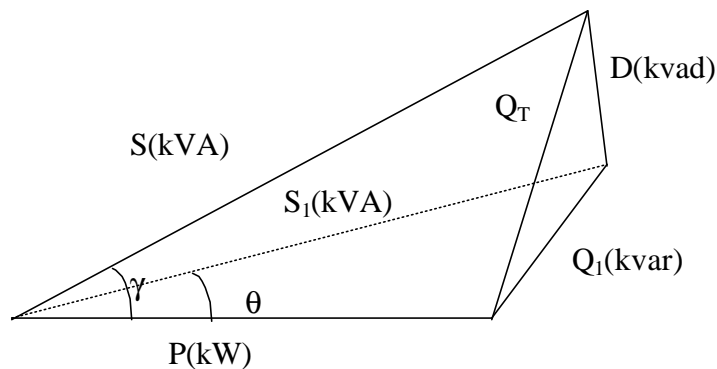

Power Triangles for Apparent Power, Active Power, Reactive Power & Distortion Power

The expression only gives an approximate formula without any voltage distortion caused by voltage drop in line impedance. These harmonic voltages will also give active and reactive components of power but the active power is generally wasted as heat dissipation in conductors and loads themselves.

5.4 Apparent and Active Power with Harmonics

Apparent power transmitted along the circuit conductors in VA,

$$S = \sqrt{3} U_L I_b \quad \text{where } I_b = \sqrt{\sum_{h=1}^{\infty} I_h^2} = \sqrt{I_1^2 + I_2^2 + I_3^2 + \dots}$$

From definition:
$$THD = \frac{\sqrt{\sum_{h=2}^{\infty} (I_h)^2}}{I_1}$$

Therefore,
$$I_b = I_1 \sqrt{1 + THD^2}$$

Assuming voltage distortion is small, $U_L = U_1$, and active power transmitted along the circuit conductors in W is given by:

$$P = \sqrt{3}U_L I_1 \cos \mathbf{q}$$

where U_L = Line to line voltage, 380V
 I_1 = Fundamental phase current of the circuit in ampere
 $\cos \mathbf{q}$ = Displacement power factor of the circuit

Assuming the skin and proximity effects are small, total copper losses in conductors including neutral in W are given by:

$$P_{copper} = (3 \times I_b^2 + I_n^2) \times r \times L$$

where I_n = Neutral current of the circuit in ampere
 $= 3 \times \sqrt{I_3^2 + I_6^2 + I_9^2 + \dots}$
 I_b = Design rms phase current of the circuit in ampere
 $\cos \mathbf{q}$ = Displacement power factor of the circuit
 r = a.c. resistance per metre at the conductor operating temperature
 L = Length of the cable in metre

5.5 Conductor Operating Temperature in 3-phase 4-wire Circuits

For circuits run singly and not totally enclosed in thermally insulated material, the conductors' actual operating temperature at phase current I_b & neutral current I_n is given by:

$$t_1 = t_a + \frac{(3I_b + I_n)^2}{(3I_t)^2} (t_p - t_r) \text{ } ^\circ\text{C}$$

where t_a = actual or expected ambient temperature
 t_p = maximum permitted conductor operating temperature
 t_r = reference ambient temperature (given as 30°C in IEE Regulations)

The resistance of a copper conductor R_t at temperature t_1 is given by:

$$R_t = R_0 (1 + \mathbf{a}_0 t_1)$$

where R_0 = conductor resistance at 0°C
 \mathbf{a}_0 = temperature coefficient of resistance of copper at 0°C (0.00428/°C)

Therefore, $\frac{R_t}{R_p} = \frac{1 + \mathbf{a}_0 t_1}{1 + \mathbf{a}_0 t_p} \approx \frac{230 + t_1}{230 + t_p}$

This ratio can be used to correct cable resistance value at its maximum permitted conductor operating temperature provided by the manufacturer for more accurate assessment of actual copper loss in the circuit.

6. Sample Calculations

6.1 Copper Loss in a 3-phase 4-wire Circuit at Various Load Conditions

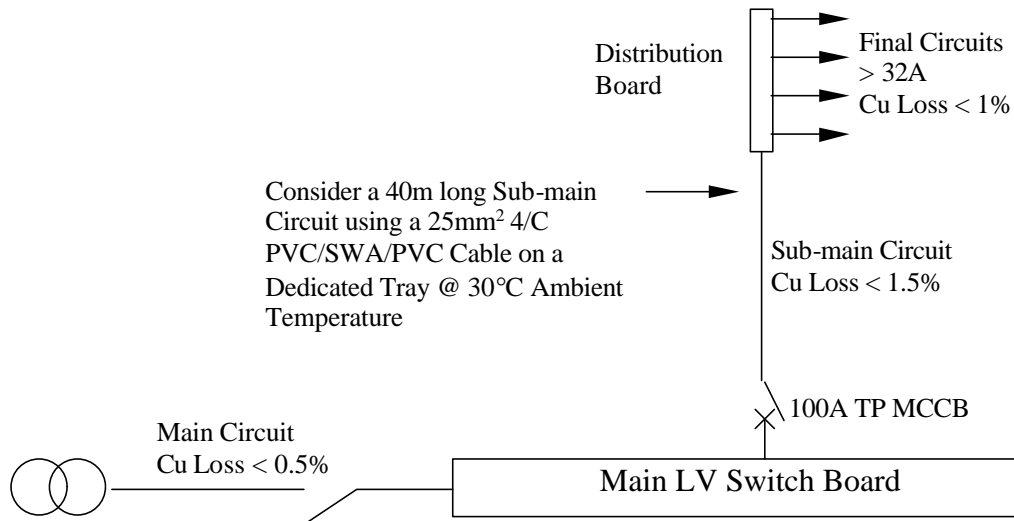

The single line diagram above shows a typical sub-main circuit 40m long and wired in 25mm² 4-core PVC/SWA/PVC cable on a dedicated cable tray at an ambient temperature of 30°C. Using the formula described above, the total power losses of conductors at various load conditions can be summarised as tabulated below:

Case no.	Circuit Load Conditions	I _R (A)	I _Y (A)	I _B (A)	I _N (A)	Conductor Temp. (°C)	Power Losses (kW)
1	100A linear & balanced	100	100	100	0	63	1.02
2	Linear but 10% unbalanced	90	100	110	17	67	1.06
3	100A balanced but 10% THD (triplen)	100	100	100	30	70 (max. temp.)	1.07
4	100A balanced but 30% THD (triplen)	100	100	100	86	85 (overtemperature)	1.36
5	10% unbalanced & 10% THD (triplen)	90	100	110	47	74 (overtemperature)	1.12
6	10% unbalanced & 30% THD (triplen)	90	100	110	103	90 (overtemperature)	1.51

From the table above, it is noted that a 3-phase 4-wire sub-main circuit originally designed for balanced and linear load conditions, would become overtemperature, unsafe and energy inefficient if unbalance or harmonics occurred later on in the circuit due to the change of load characteristics or power quality.

6.2 Conventional Method and Energy Efficient Method for Cable Sizing

Using the example in case (1) above, the effect of cable sizing based on (a) conventional method (i.e. minimum safety requirements to comply with Electricity (Wiring) regulations), and (b) Energy Efficiency Method (i.e. maximum power loss requirements to comply with Electrical Energy Code), can be analysed in the following table:

	Conventional Method	Energy Efficient Method
Balance & linear load rating	100A	100A
Power factor	0.85	0.85
Protective device	100A TP MCCB	100A TP MCCB
Circuit length	40m	40m
Correction Factors	1	1
Minimum cable size required	25mm ² 4/C PVC/SWA/PVC	35mm ² 4/C PVC/SWA/PVC
Current-carrying capacity	110A	135A
Conductor temperature	63°C	52°C
Voltage drop	5V (1.3%)	3.7V (1%)
Copper losses	1.02kW	0.7kW
Active power transmitted	56kW	56kW
Percentage copper loss	1.8% (> 1.5%)	1.2% (< 1.5%)

By limiting the power loss to within 1.5% and applying the energy efficiency method for cable sizing, the minimum conductor size required is 35mm² square. The 35mm² armoured cable will provide a current-carry capacity of 135A, conductor operating temperature of 52°C and a power loss of 700W (i.e. only 1.2% of useful power). The circuit should then be safer and more energy efficient and allow more spare capacity to minimise the risk of inadvertent overheating from temporary overload or harmonics. This has an end result of complementing the existing electrical safety standards and regulations.

6.3 To Supplement Other Energy Codes

Other Building Energy Codes for lighting, air conditioning and lifts & escalators, recommend the utilisation of energy efficient equipment such as electronic ballasts, variable speed drives (VSD), VVVF etc. which are regarded as non-linear loads requiring special attention with respect to both safety and energy efficiency in the circuit design. The example below demonstrates how the Electrical Energy Code can supplement the requirements of variable flow systems in Air Conditioning Code and the way to reduce harmonic-related losses in the power system.

Supposing the sub-main circuit considered previously is now required to handle AHU loads with variable speed drives (VSD) to comply with the Air Conditioning Code. The cable sizing shall be carried out according to the characteristics of the harmonic currents at full load and full speed conditions (Fig. 4), taking into account both the safety and energy requirements for the circuit.

It is very important to note that the circuit must be designed to operate at its worst case condition (i.e. all VSDs are at full load full speed) even harmonic filters are used to compensate its distortion power, otherwise, the circuit might be overloaded in case of filter failure. The table below summarise the circuit design calculations:

	Circuit 1	Circuit 2
Cable size	35mm ² 4/C PVC/SWA/PVC	50mm ² 4/C PVC/SWA/PVC
Protective devices (I _n)	100A TP MCCB	160A TP MCCB
Design Current (I _b)	133A	133A
Current-carrying Capacity (I _z)	135A	163A
Conductor temperature	69°C	57°C
Copper loss	1.5kW	0.94kW
Active power	6.6kW	6.6kW
Percentage loss	2.2% (>1.5%)	1.4% (<1.5%)
Comply with safety requirements	No (I _b > I _n)	Yes
Comply with energy efficiency requirements	No (>1.5%)	Yes

It is interesting to note that the displacement power factor of the circuit is almost unity, as the phase shift between the supply voltage and the fundamental current component is small, but the total power factor is found to be 0.75. In this case, capacitors cannot be used to correct the power factor and other means of harmonic filtering can only be used to compensate the distortion power and improve the total power factor of the circuit.

Circuit 1 was the original design of the sub-main circuit to cope with the previous balanced and linear load conditions. If the loads were changed to non-linear VSDs with harmonics, the circuit would become unsafe and have to be redesigned as Circuit 2 above with a minimum conductor size of 50mm² in order to comply with both safety and energy efficiency requirements.

7. Elimination of Harmonic-Related Losses

The cost of harmonic-related losses depends on the loading condition, time of operation, and the conductor length. Harmonic elimination or reactive compensation at the source of harmonic generation, before any additional current flows in the power system, will always be the most complete and effective approach. However, this will lead to many small rather than a few large filtering devices. The expected economy of a large-scale harmonic filter suggests that the best location is where several distorted currents are combined, such as the motor control centre (MCC) feeding several VSDs. Compensation of harmonics near the service entrance, or metering point, has very little value for reduction of harmonic-related losses.

With incentives like IEC Standard 1000-3-2, which require some mitigation of harmonics at equipment terminals, many electronic equipment manufacturers are now looking for cost-effective ways to reduce harmonics inside their products. Recent tests on some electronic ballasts in Hong Kong revealed that THD current could be lower than 5% with built-in harmonic filters as compared with the previous products with THD above 40%. Similar harmonic filtering devices could also be incorporated into the design of electronic office equipment and other consumers' products to limit harmonics for compliance with the IEC standard. As far as the large non-linear loads are concerned, such as VSD with 6-pulse Pulse Width Modulation (PWM) and VVVF lift drive system, reduction of harmonics could be

achieved by the installation of individual dc-link inductor, ac-side inductor, passive or active filter, etc.

8. Conclusion

With the proliferation of non-linear loads nowadays, harmonic-related losses in building wiring systems will be worsened. These losses may cause significant safety problems, overheating conductors, increasing power bill, and tying up capacity of the power system. Reducing harmonics will save energy and release additional capacity to serve other loads.

Compliance with the harmonic requirements of the Electrical Energy Code could be achieved by applying harmonic filtering devices at appropriate location. The great potential for loss reduction and released power system capacity is near the harmonic generating loads, while compensation near the service entrance is of little value. For designing the power system of a new commercial building, future harmonic problems need to be considered and a certain percentage of harmonic distortion must be allowed for and incorporated into the design. The general practice of installing capacitor banks at the main LV switchboards for main power factor correction should be re-considered. Ordinary capacitor banks can no longer be used to correct low total power factor caused by harmonics. The capacitor would act as a harmonic sink and could be damaged by high frequency harmonic or resonance currents passing through it.

Active filters, tuned or broadband passive filters are required to solve existing and future harmonic problems for compliance with the requirements specified by the government and the power companies. Application data on these filters, for use in both harmonic reduction and reactive compensation, is not adequately available in the market or in standards. Further investigation comparing the effectiveness and cost of various harmonic mitigation technology requires further elaboration among the government, electrical consultants, manufacturers and the power companies.

There are many opportunities for reducing losses and consumption of electricity in Hong Kong buildings. It is the aim of the Government to improve, in long term, the use of energy in Hong Kong buildings particularly of electricity through energy efficiency and conservation measures. Harmonic distortion, being one of the major factors affecting the efficient use of electrical energy and safety in a modern power distribution system, have already been raised by the government and the power companies as a main issue to be tackled urgently.

Reference

- [1] "Draft Code of Practice for Energy Efficiency of Electrical Installations", January 1997, Energy Advisory Committee.
- [2] "Code of Practice for Energy Efficiency of Lighting/Air Conditioning Installations", 1998 Edition, EMSD.
- [3] RS Chin and KC Chan, 'The Efficient Use of Energy in Electrical Systems of Buildings', Symposium paper on Electrical Services in Buildings, 6 November, 1996.
- [4] IEEE Recommended Practices and Requirements for Harmonic Control in Electrical Power Systems, IEEE Standard 519-1992.
- [5] T. Key and J. Lai, "Cost and Benefits of Harmonic Current Reduction for Switch-Mode Power Supplies in a Commercial Office Building", IEEE Transactions on Industry Application, Vol.32, No. 5, September/October 1996.
- [6] "Supply Rules", December 1999, CLP Power.

- [7] IEC 1000-3-2 “Limits for harmonic current emissions (equipment input current $\leq 16\text{A}$)”, 1995.
- [8] IEC 287-1-1 “Electric Cables – Calculation of the current rating – Part 1”, 1994.
- [9] “Code of Practice for the Electricity (Wiring) Regulations” 1997 Edition, EMSD.