

**Guidelines on Application of
Central Control and Monitoring Systems**

Energy Efficiency Office

1.	PREFACE	3
2.	Introduction	4
2.1	General Description	4
2.2	System Benefit and Cost Analysis	6
3.	Applications and Functions	7
3.1	Real Time Display	7
3.2	Alarm Status	8
3.3	Management Information, maintenance, fault attendance logging	8
3.4	Simple and economic integration of CCMS	9
3.5	Remote programming of DDC controller	9
4.	Hardware and Software	10
4.1	Hardware	10
4.2	Software	13
5.	Trend & Development	14
5.1	Open Protocol and Interoperability	14
5.2	Web-based interface	14
5.3	System integration	15
5.4	Control technologies	15
5.5	Sensor technologies	15
6.	Energy Management Strategies	16
6.1	Operation and Maintenance Schedule	16
6.2	Lighting Installation	17
6.3	Electrical Installation	17
6.4	Lifts and Escalator Installations	18
6.5	Air-conditioning System	19
7.	Inter-action between Systems	27
7.1	Air-conditioning systems	28
7.2	Lighting system	28
7.3	Electrical System	29
7.4	Lift system	30
7.5	Integrated design	30

1. PREFACE

The Building Energy Codes on Energy Efficiency of Air-conditioning, Lighting, Electrical and Lifts & Escalator Installations were written in a prescriptive nature on the requirements of design practice and equipment performance standards and with less regards on energy management. To supplement the foregoing, this Guideline is developed to introduce methods of energy saving opportunities through the use of Central Control Management System (CCMS). It is not intended to issue a Code of Practice to accompany with this Guideline as energy saving can be achieved through various means beside using CCMS. It is the objective of this handbook to provide some guidelines in the application of CCMS to achieve energy efficiency in building for the reference to designers and building operators.

2. Introduction

The main objective of this Guideline is to introduce the application of Central Control and Monitoring System (CCMS) for energy management in buildings. Contemporary application of the technology in CCMS in the energy management of modern buildings is briefly introduced. This Guideline serves to assist building services system designers and operators to apply CCMS to energy efficient building operation.

The Building Energy Codes in Air-conditioning, Lighting, Electrical and Lift & Escalator Installations are prepared to address good energy efficiency practices in buildings. However, for those buildings, where the systems are interacting with one another, higher overall energy efficiency can be achieved, if integrated design, particularly at the design stage is incorporated, such that operation change in any particular system can well be reflected to its associating systems so that they, as a whole can effectively self-adjust themselves to cope with all such changes.

In order to allow for good communication between systems, employing modern CCMS is a good choice as it provides great flexibility for expansion and changes in operation. Besides, CCMS also provides convenience for automatic day-to-day operation and can reduce the frequency of failure due to occurrence of human errors.

2.1 General Description

As we have entered the new age of information technology, electronically enhanced buildings have gone through more than 20 year of the development history. A modern building is one equipped with the information technology infrastructure that enables it to continuously respond and adapt to changing conditions, allowing for a more efficient use of resources and increasing the comfort and security of its occupants. Due to hardware and software limitations, older buildings lack the necessary integrations among various control aspects. Nowadays, modern buildings are usually controlled and monitored by a CCMS which is the “brain” of the buildings during their daily operations. The most widely accepted framework for the CCMS in an intelligent building is a two-tier or three-tier distributed architecture. These two tiers include the outstation controllers and the central monitoring computer with data communication wiring connection in between. The controllers are local microprocessor based devices to implement actual control algorithm (e.g. PID algorithm) for the actuators under control. They are usually installed next to the equipment to be controlled. The controllers receive control commands such as set point,

on/off instructions from the central control and monitoring computer to carry out the designated functions. This two-tier configuration ensures the building's functionality even the central control and monitoring computer is temporarily out of service. Additionally, sensors and transducers are installed at various parts of the engineering systems to send the condition signal back to the controller for control and monitoring purpose. The new trend of Intelligent Buildings is concentrated on both economic and environmental sensitive developments. Flexibility and low energy have become the issues that must be addressed to cope with the fast growing technology and ever changing of the modern world. Besides operational advantages, Intelligent Buildings also project high technology image to the property market. This gives the buildings additional cutting edges in the tight market.

The building's features that can be looked after by the CCMS basically fall into four categories. They are:-

- Energy efficiency - reduction of energy consumption through effective energy management algorithms,
- Life-safety systems – reduction of manpower dependence, access control, smoke detection, fire alarm, intrusion alarm, and emergency control of HVAC and lifts etc,
- Telecommunications systems – telephone system, electronic mail system and cablevision etc,
- Workplace automation – central data processing, facility management etc.

The following diagram outlines the features that modern CCMS addresses:

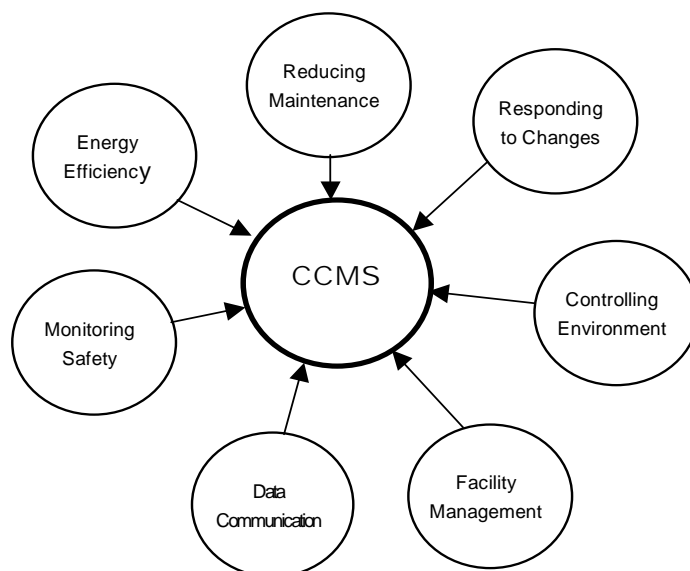

Through the use of CCMS, the building under controlled can be monitored and operated 24 hours a day, 7 days a week. Compared with traditional facility management set up, CCMS provides a systematic tool for building manager to operate the building. Routine operations can be programmed and operated automatically everyday. Building manager can set free more time to take care of other strategic issues or attending, serving the tenant.

2.2 System Benefit and Cost Analysis

Implementing and using a CCMS will bring several advantages. Some are quantifiable and some are not quantifiable. Quantifiable advantages are energy savings, the reduction of operation and maintenance costs, better returns on investments on CCMS, and possibly higher property leasing rate. Non-quantifiable advantages include more comfortably built environment, increased building’s facilities availability, enhanced productivities, and better deployment of technical skilled personnel, faster information exchange, less complaints from tenants, and enhancement of the building’s image.

The cost for implementing a CCMS exclusively follows the economy of scale. Although the total cost increases with raising number of monitoring points and control points, the unit cost per point is lower for large system with more points installed than one with less points. Preliminary capital cost estimate is based on the quantity of points to be installed in the system that is in turn related to the building area as well as the desired function level. Typical application such as the control for institutional building of a hospital block can involve as much as 2000-3000 points, while those prestigious buildings or major facility with full CCMS implementation ranges from 4,000 to 40,000 points. Simple applications such as controlling the HVAC system merely involve only 100-200 points. The following graph showed the unit cost per point plotting for one of the manufacturer’s projects:

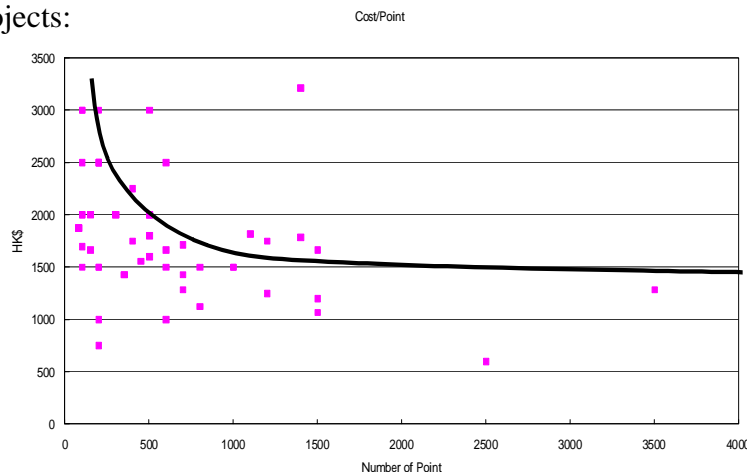

Although the above graph indicates price scattering for CCMS installation, it can be used as a reference for preliminary capital cost trend. The scattering may be due to site areas differences as well as difference in implemented function. It can be seen that price per control point drop rapidly with the increase in total points number. When the system is exceeding 1000 points, the price stabilised. Thus from the capital point of view, large system is more cost effective than small system. A number of manufacturers quoted that installing CCMS can cut down the electricity bill by about 20%. It should be noted that a number of factors affect this saving. Example of these factors include:

- The condition of the plant equipment
- Existing O&M service levels
- The skill and knowledge of the O&M team
- The operating features of the premises

The designer must work closely together with the management and manufacturer to ensure the CCMS systems may be implemented and integrated with the main plant and equipment smoothly and effectively. The essential elements for a successful CCMS system need to include the followings, i.e. guarantee energy savings, accurate controls, real-time problem analysis, prompt alarm reporting, accurate management reporting, sufficient history data trend reporting, maintenance cost saving and increasing operation efficiency.

3. Applications and Functions

3.1 Real Time Display

One of the advantages of utilising CCMS is its real time display function. This function improves building manager's attendant time especially if the building area is widely spread or the facility contains multiple blocks. The application program that runs on the central control and monitoring computer provides the user interface, usually in graphical form, to operate and monitor the system. Control status as well as sensors' readings can be displayed real time on a computer monitor screen. Furthermore, data can also be displayed in different format, grouping, carry out arithmetic calculations, and any possible ways. This allows the building manager be presented with reports that identify the problem areas. Users of the CCMS can switch on/off or change the settings of equipment directly on the computer screen. Nowadays, CCMS are usually developed under windows base platform and providing graphical user interface to reduce the use of keyboard. This reduces the need to memorise commands. Real time data, if properly

attended, can foretell potential problems well before they actually occur. This can effectively reduce building tenants' complaint due to service interruption or lowering comfort levels. Building manager visualising the real time data of the whole system on a computer screen can diagnose the system problems more easily and focus more effectively on the problem solving strategies.

3.2 Alarm Status

The central control and monitoring system can monitor a building system performance 24 hours a day. Program can be set to produce alarm if certain combination of performance data exceeding some thresholds and need attention and necessary action. Examples are unexpected security intrusion, air temperature too high/low and humidity of critical storage too high, etc. Alarm status can be customised and logged for recording service history of the building or for improvement analysis. The alarm status can be integrated with an overall alarm management system for processing or forwarding to other workstations in the network.

3.3 Management Information, maintenance, fault attendance logging

As CCMS monitor the engineering services 24 hours a day, data collected can form useful management information to enhance facility utilisation and maintenance. Some examples include:

- Automatic trending and reporting of a building's key performance indicators such as energy cost per square meter.
- Comparison of operating efficiency between several floors of a building. For example, when a CCMS reports that the energy of Floor A costs more than that of per square meter of Floor B, the building manager knows that there is problem with Floor A that needs to be checked. Further investigation could result in determination of a piece of equipment, such as a chiller unit, that needs to be replaced or repaired.

On the other hand, CCMS can keep track of equipment's total running hours and generate reports for maintenance team on items that are due for replacement or servicing. Preventive maintenance can be managed in a more systematic and cost effective manner to avoid excessive maintenance before the equipment's actual failure. Besides, preventive maintenance can also be planned basing on variation on energy use or equipment

performance that can also be tracked by CCMS.

When the equipment under monitoring having unexpected failure or service interruption, CCMS will generate fault alarm to draw the attention of the operator. In some systems, the alarm can be directed to pagers or other communication equipment for immediate action. The time for the maintenance team to reinstate the service can also be logged for evaluation and record purpose.

3.4 Simple and economic integration of CCMS

CCMS can provide a simple platform for integrating engineering services within a building. Security system, life safety systems, HVAC, data communication systems etc. can be monitored and controlled in a single workstation. In large development, several buildings can be integrated via modern Internet technology. It should be pointed out that integration does not merely mean a common control for a number of building services installations, it should also provide opportunity to cut cost, enhance reliability through sharing resources.

Beside systems integration, advanced CCMS can also be integrated with other building management and business accounting systems to program the auto-switching of the supporting facilities to match the occupancy schedule, for example, to save energy and to protect the control area, CCMS can switch off air conditioning, lighting systems and to turn on the security system after the area is vacated. Also the energy consumption of production floor can be directly benchmarked with business turnover or revenue to evaluate and monitor business performance and efficiency.

3.5 Remote programming of DDC controller

Direct Digital Controllers are microprocessor-based controller equipped with digital/analogue input/output points and real time clock. It is most commonly used as the second or third tier controller in a CCMS and is installed next to the plant. Its function is to carry out the actual control algorithm between the sensors and actuators. Common control algorithms include standard PID control loops, heating/cooling control loops, switching and windowing functions, maximum and minimum functions, logic functions, delay functions and numerous configurable delays and overrides, etc. DDC usually contain pre-installed firmware, however, it has to be configured before it can actually work. This configuration specifies how the inputs to the DDC are to be processed to drive the

DDC outputs. Most systems distribute the software to remote controllers to eliminate the need for continuous communication capability (stand-alone). The central workstation is primarily used to monitor the status of the system, store back-up copies of the programs and record alarming and trending functions. Complex strategies such as energy management functions are readily available at the lowest level in the system architecture. Programs and parameters distribution can be carried out in a remote terminal via the communication network. The communication network can be a twisted pair network or an Ethernet network. In case an Ethernet network is used, the CCMS can be integrated with WAN or LAN.

4. Hardware and Software

4.1 Hardware

Modern CCMS utilise distributed processing configuration and structure to maximise efficiency and reliability.

The basic elements of a CCMS include:

- Central monitoring computer / workstation
- Alarm & log printer
- Pointing device
- Network interface unit
- Outstation
- Communication network
- Sensors
- Actuators

Other optional parts include:

- Uninterrupted power supply
- Standby workstation
- Standby alarm & log printer

The basic arrangement is illustrated in the following diagram:

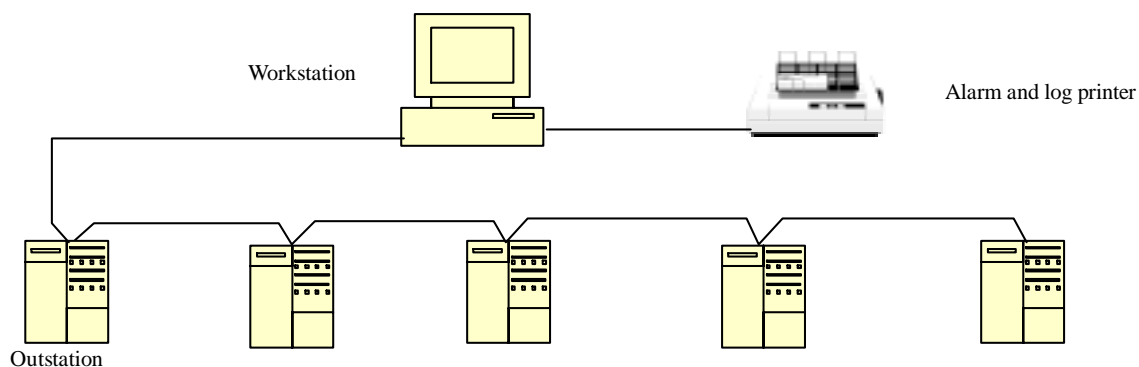

The workstation provides a graphical interface for operator to operate and monitor the services under the CCMS control. All on/off scheduling, set point and operation instructions are entered into the workstation. The workstation then communicates with the outstations through the communication network, distributing the instruction to the outstations to perform the actual control actions. Sensors signals can also be read from the outstations through the network. It should be noted that under this two-tier structure, the plant can still be operated even when the workstation or the network is out of service. This increases the reliability of the whole system.

Outstations nowadays are usually microprocessor-based controllers, i.e. the Direct Digital Controller (DDC) with control logic carried out by software. They receive control instructions from the workstation and react to the sensors input.

Large system may involve multiple workstations. Nowadays, they are usually linked up together with Ethernet. An example arrangement is as follows:

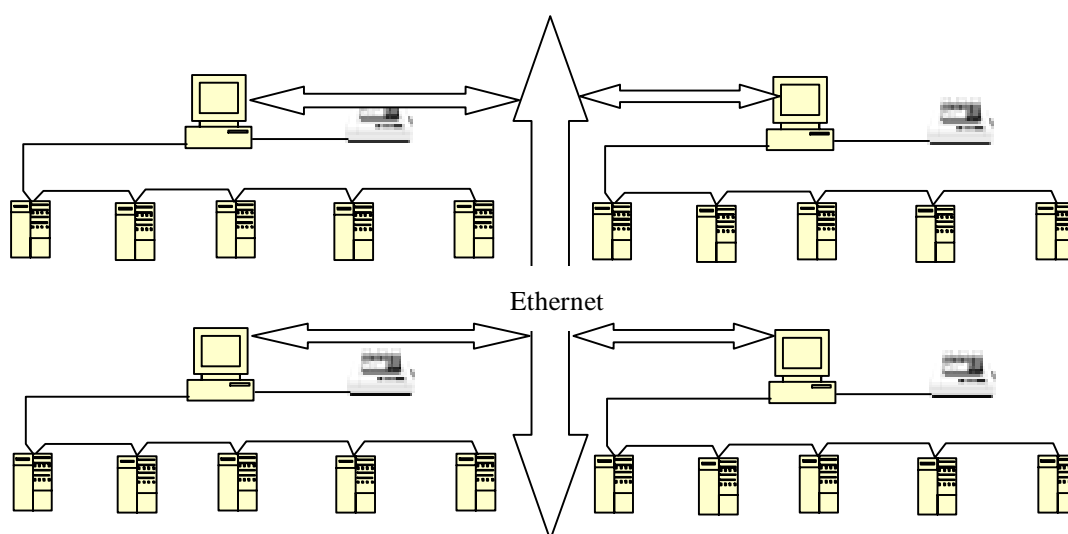

One of the important issues on CCMS is the compatibility among different manufacturers. It is usually referred as “interoperability”. It is especially important when future expandability is considered.

Incompatibilities between products from different manufacturers are encountered when designers attempted to interconnect DDC systems or devices from different manufacturers. Incompatible communication protocols, data formats, and electrical interconnections made it very difficult to exchange information. Some CCMS use communication gateway at workstation level to share information. However, the translation of different

communication protocol still does not guarantee 100% compatibility. In an effort to create a standardized method of interconnecting building services subsystems from different manufacturers, the American Society of Heating Refrigeration and Air Conditioning Engineers (ASHRAE) set about to create an open standard called Building Automation and Control NETWORK (BACnet). BACnet was originally intended to eliminate the need for proprietary gateways between workstations by defining a standardized means of communicating over a local area network (LAN) to which the workstations were connected. However, BACnet compatible devices from different manufacturers are still not 100% compatible because of the optional features of these devices. All of the features of a device are presented in a device's Protocol Implementation Conformance Statement (PICS). A specifying engineer needs to know which objects and services are supported by which devices, since this varies from device to device, and the PICS provides most of this information. The difference in PICS may defeat the compatibility between BACnet conformance devices.

BACnet was designed specifically for building automation and control applications while LonWorks was designed to be a general-purpose control network solution. The consequence is that some of the functions intimately associated with building controls, and central to BACnet, such as time-of-day scheduling, alarm generation, and control prioritisation, are simply not present in LonWorks. Moreover, BACnet is designed to be scalable, i.e., it can be applied to very small or very large systems with equal effect. LonWorks, as it exists today, is most suitable for systems with a small number of nodes. The capabilities of the Neuron, and performance limitations imposed by limited memory architecture within the Neuron chip and the design of LonWorks place practical limits on the size and scope of LonWorks. In the market product, LonWorks are usually used in the outstation level while BACnet is on the workstation level.

4.2 Software

Software used in the workstation is usually developed on windows base platform providing multitasking capability for concurrent processing of different programs. The software usually provides the graphical operator's terminal interface, allowing user to interrogate and collate information. Graphical user interface is usually multiple windows and in the form of schematic representation of buildings and installed plant. The following diagram shows one of the examples:

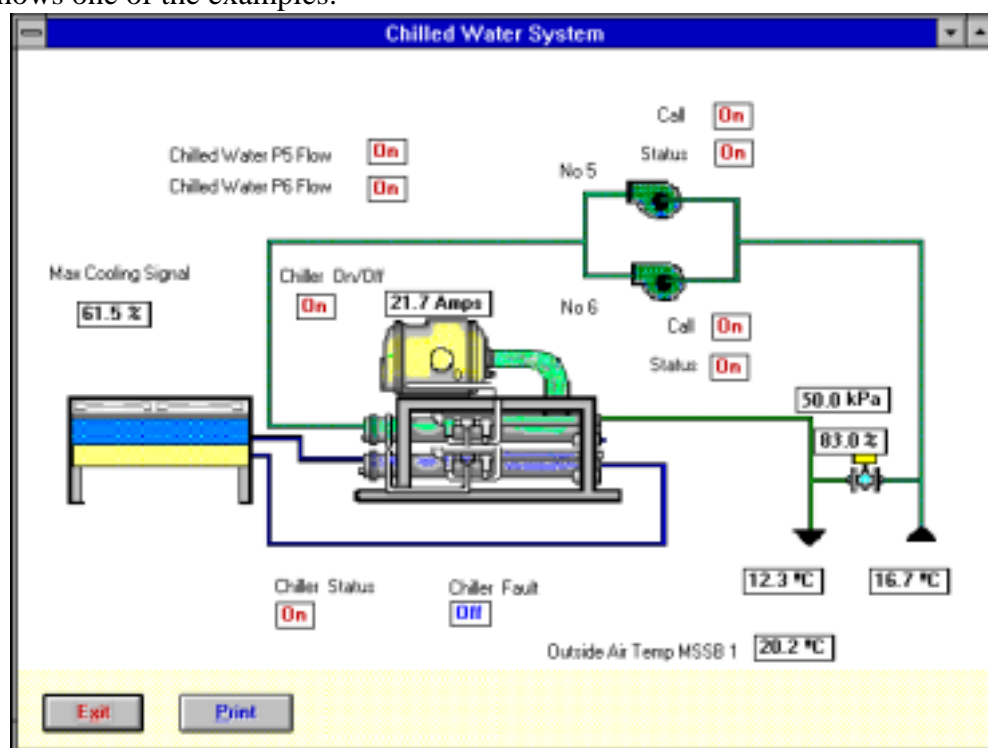

Data logging capability is usually built into the software for recording current state or value of points or groups of points. Data logged can be presented as line graphs or any other format for easy management analysis.

Software used in outstations is usually firmware that is pre-installed in the controller. Standard control algorithms are pre-programmed and user only needs to choose the correct control algorithm and set the parameters to suit his needs. There are basically three common approaches used to program the logic of DDC systems. They are line programming, template or menu-based programming and graphical or block programming. Line programming-based systems use BASIC or FORTRAN-like languages with HVAC subroutines. A familiarity with computer programming is helpful in understanding and writing logic for HVAC applications. Menu-driven, database or template/tabular

programming involves the use of templates for common HVAC logical functions. These templates contain the detailed parameters necessary for the functioning of each logical program block. Data flow (how one block is connected to another or where its data comes from) is programmed in each template. Graphical or block programming is an extension of tabular programming in that graphical representations of the individual function blocks are depicted using graphical symbols connected by data flow lines. The process is depicted with symbols as on electrical schematics and logical control diagrams. Graphical diagrams are created and the detailed data is entered in background menus or screens.

5. Trend & Development

The development trend of CCMS is greatly influenced by the blooming of information technologies. Most of the developments are now on the system integration part. The following are some trends in CCMS development:

5.1 Open Protocol and Interoperability

The communication protocol will be fully based on open protocol to ensure product interoperability from different manufacturers.

To avoid coordination problem among the users and various manufacturers, the designer must be familiar with the standard and open protocols to specify the exact details of the control system, such as the communication levels, communication properties, system objects, etc. Furthermore, the manufacturer should submit for acceptance before installation the Protocol Implementation Conformance Statements (PICS) for the BACnet systems. Besides, the designer should also specify the procedures and arrangement for commissioning, future maintenance and modification works among the manufacturers.

5.2 Web-based interface

The workstation software will utilise the Internet technologies. Instead of proprietary made software, ordinary web browsers can be used for the graphic interface of the system. The web interface enhancement makes building data available to everyone in the organisation, and may be the best way to demonstrate the true value of DDC on a broad scale. This is because data that was only available to facilities staff can be used for decision making throughout the organisation by such diverse groups as finance and operations staff. In addition, this web interoperability makes a host of management advances possible.

5.3 System integration

Control systems in the future will be networked to operate as integrated systems. The system will link up with a robust performance tracking database engine to monitor and record information on various performance aspects of building systems and their real-time attributes including HVAC, lighting, and shell components. Integrated building systems and their control technology will be linked to software modules that compare actual performance to original design objectives, metrics, and functional intent.

5.4 Control technologies

Some specific control developments will include:

- Adaptive/optimized/self-generating control algorithms: Development of techniques whereby control algorithms adapt to changing building or system conditions, adjust set-points and subsequently algorithms themselves to be optimal, and eventually support automatic generation of control strategies based on the equipment and systems present
- Advanced control techniques: Development of control techniques based on artificial neural networks, fuzzy logic, and genetic algorithms.

5.5 Sensor technologies

Existing sensor problems such as severe sensor calibration, drift, and placement errors resulting in unreliable measurements have to be solved before control technologies can be successfully implemented. Sensors in the future should be self-identifying, self-diagnosing, and self-calibrating sensors. Future buildings will need far more sensors than today's, with additional measurements of energy use for evaluating system and component energy use, plus indoor environmental quality to identify contaminants, and comfort measurements that include radiant temperatures, local air flow and humidity. Specific R&D outputs are as follows:

- New cost-effective sensors and monitoring systems related to indoor air quality.
- New cost-effective and practical sensors related to thermal environmental conditions, including radiant temperature and humidity.
- New cost-effective sensors for water and air flows in central plants and distribution systems.

- Sensors with improved calibration and uncertainty characteristics, including self-diagnostics and reduced drift.
- Protocols for sensor installation, placement, and commissioning, including documentation methods.
- Modeling of real sensor characteristics.
- Protocols for uncertainty analysis for sensors used in buildings.
- Protocols for sensor selection including costs and performance (error) characteristics.

6. Energy Management Strategies

The CCMS is able to process simultaneously large quantity of data influx from hundreds or even thousands equipment, sensors and in return, issue instructions to assure the most optimum and comfortable condition for our client. Besides, we can also make use of the CCMS technology to save energy for the building services equipment or systems. These include:

- Load profiling to determine load factor, peak demands, facility consumptions,
- Cost allocation to analysis the departmental, or process energy costs,
- System monitoring to measure the overall major items performance,
- Load shedding or trimming to reduce power charge,
- Demand management,
- Power quality monitoring for harmonic, surge, etc.

The most commonly applied technology includes the followings:

6.1 Operation and Maintenance Schedule

Good operation and maintenance scheduling can ensure that systems are always running at their best efficiency. Consequently, it would reduce system downtime and also ensure that the most efficient units are running at most of the time especially during part load conditions.

When sufficient transducers are installed at suitable location of a network, energy flow in the whole building can be accurately monitored. This can help checking whether any systems are complying with the BECs. It is also useful when it is necessary to determine what kind of improvement work is required to enhance energy efficiency.

Besides tracing how energy is being consumed, energy audit will be found useful one day when the tenants of a building ask for a fair billing arrangement. Billing the tenants on the exact amount of energy, or air-conditioning, consumed shall be encouraged or otherwise all tenants would not concern about energy wastage.

6.2 Lighting Installation

By integrating control of artificial lighting with the availability of day lighting, lighting can be dimmed down or switched off whenever luminous intensity level is sufficiently supplemented by daylight. On the other hand, switching off lighting in unoccupied areas by occupancy sensors can achieve substantial savings. If lighting components can communicate with each other easily, such a control can enhance energy efficient greatly but without impairing the visual comfort of tenants.

Outdoor lighting can be controlled to cater for the seasonal change in the availability of daylight.

6.3 Electrical Installation

Sometime switching off part of the non-critical loads during peak hours may help reducing the tariff charge, hence it is so worthwhile to control these loads individually so as to gain the tariff benefit. Of course, energy savings is associated with all these managerial procedures, besides savings in tariff charge.

Power companies in Hong Kong offer special tariff rates, e.g. bulk supply tariff, for large consumers. More favourable tariff rate will be charged to the consumers when consumptions are mainly with active power. For the sake of acquiring the most favourable tariff rate during peak load condition, control of non-active power consumption in the system is critical. This is commonly achieved by compensating the load reactive power by switching in appropriate amount of capacitors. Usually this is done by an automatic controller provided by the capacitor bank manufacturer but over-compensation may occur if the capacitors are not divided into sufficient number of banks.

Power factor corrected to a minimum of 0.85 is encouraged in the Electrical Code. Distribution losses can be much reduced if power factor is improved to well above this limit. By carefully controlling the amount of capacitor added, power factor of unity can be attained. Should it be attained, copper loss in the circuit will be reduced by 27.75%.¹

It is a good practice to monitor the on-line true power factor of the system and calculate the amount of capacitor required to achieve unity power factor and then switch on them.

As power factor of a distribution system fluctuates a lot, the above arrangement will be successful if power thyristors are employed for fast switching of capacitor.

For systems incorporated with active harmonic filter, unity power factor can be achieved easier as some filters do have the ability to correct the power factor to unity on top of filtering harmonic currents.

Copper loss in every major circuit can be calculated and monitored. Some other important power quality indicators specified in the Electrical Code, such as total power factor, reactive power, distortion power, voltage unbalance, motor efficiency etc., can also be calculated and monitored as long as sufficient and appropriate transducers are installed. In the case of exceeding any limits occasionally, the problematic areas can be identified easily and proper mitigation actions can be taken. Deterioration in system performance, such as drop in motor efficiency, can be revealed at early stage and sufficient time for planning maintenance and outage can be allowed.

6.4 Lifts and Escalator Installations

The status of each lift, such as position of lift car, going up or down, answering call etc., can be monitored. CCTV signal within lift cars can also be accessed through CCMS. Besides, no other controls on these systems will be found.

In section 4.6 of the Lift Code, the requirement for total power factor of lift supply feeder to be above 0.85, is addressed. For lift motor drives using power electronic technology, it is inevitably that harmonic currents exist in the supply feeder. Present power factor correction controllers are sometimes not intelligent enough to determine whether poor power factor is due to harmonic current or due to reactive power consumption of the lift drive. If this is due to harmonic currents, switching in compensating capacitor will not help improving the power factor and may even make it worst. If CCMS is employed to monitor the electrical supply parameters mentioned in section, then the correct amount of capacitor required for achieving the best power factor can be determined.

There are similar requirements for escalators and passenger conveyors as stipulated in

sections 5.1 & 5.4 of the Lift Code. Again, CCMS can do the task well. Lift traffic for most of the commercial buildings are busiest during the morning peak when people return to their office and also during the evening peak when most of the people are off duty. However, traffic in other periods of the day is much less busy. If buildings are designed with lift system capable of handling the peak demand well, during other periods, the system is supposed to have surplus capacity. By shutting down some of the lifts during off-peak hours, the energy efficiency of lift system can be much improved.

Section 4.2 of the Lift Code mentioned about the Energy Management of Lift System. It is suggested that during off-peak hours, at least one lift car per lift bank shall operate under standby mode. Since exact off-peak hours of each building various and in order to have the best energy management, this off-peak hours can be determined by past records of usage of the lift system. CCMS is a good tool for tracking the usage pattern of lift system.

Traffic analysis is used to determine the strategy for lift parking during off-peak hours and past records of usage is essential for lift traffic analysis.

As specified in section 4.2 of the Lift Code, monitoring some of the electrical supply parameters on the supply feeder is required. All these data can be logged accurately if CCMS is employed.

6.5 Air-conditioning System

6.5.1 Optimum Start-up/Switch-Off Times

It is usually necessary to start-up and switch off the HVAC system to pre-cold or pre-heat the building before and switch them off earlier after the occupancy period. The “optimum start-up/switch-off times” is aiming to consider and define the minimum time start-up and stopping the HVAC equipment without losing control of the internal environmental conditions. This needs to take into account of the indoor, outside conditions, i.e. temperatures, and relative humidity, occupancy schedules. The built-in program will measure all variables from the temperature and humidity sensors to calculate the thermal load requirement and hence the shortest lead time to pre-start and stopping of the HVAC system and equipment to enable the optimum energy saving. ^{II} Several algorithms had been developed and applied in the HVAC systems. It is not uncommon to reduce the operating capacity of the fresh air or exhaust fans, during the pre-start up and stopping periods, while still need to take the special consideration to maintain the healthy

and comfortable, safe interior environmental condition for the occupants.^{III}

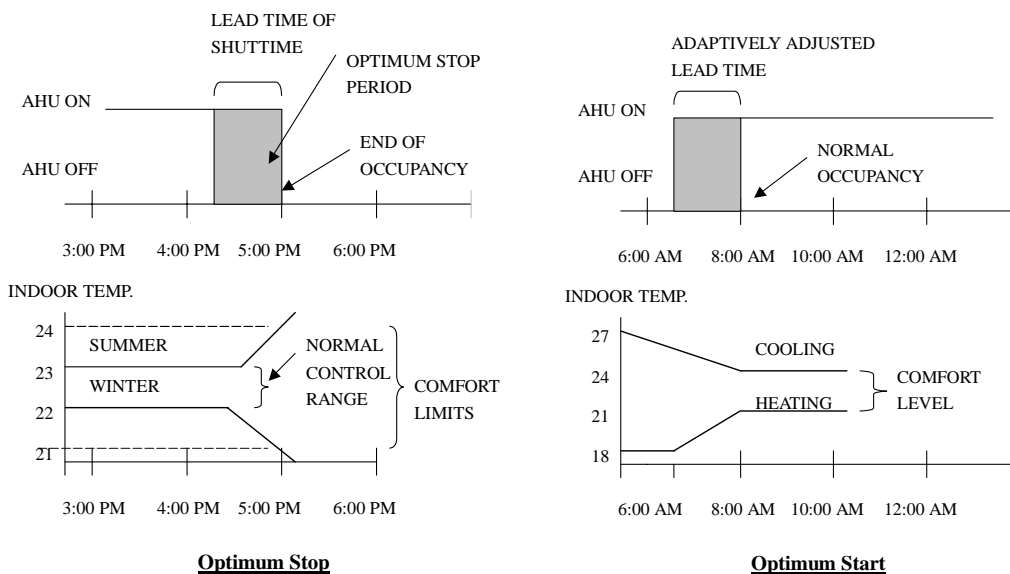

6.5.2 Economizer Cooling

This makes use of the free cooling by means of the outside air intake whenever the outside dry bulb air temperature falls below the indoor mixed air temperature. The program will measure the mix air temperature, outdoor temperature and the fresh air requirement to control the air volume to enable optimum energy saving and the indoor air condition.

This is also applicable for the waterside economizer where the condenser cooling water will be circulated instead of chilled water to cool down the building. This will be effective when the outside wet bulb temperature is about 2 to 4⁰C lower than the required chilled water air temperature. However, wherever the system uses humidity or enthalpy controls, it could not use condenser water for cooling purpose, since they need the normal chilled water supply to control and monitor both the dry bulb and wet bulb temperature.

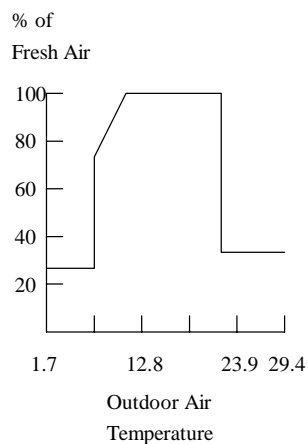

Economizer Cooling
(Fresh Air Temperature Control)

^{IV}To ensure the accuracy to measure and control the minimum fresh air intake, special attention is needed to apply and use different fresh air flow rate measurement and control to meet CAV and VAV systems, i.e. the fixed minimum outside air damper position, and the volumetric fan tracking technique for CAV system, while the averaging pitot-tube array station, electronic thermal anemometer, and CO² concentration balance technique for the VAV system.

6.5.3 Enthalpy Control

In this control system, the program will control with dampers the fresh air intake by comparing the outdoor air enthalpy values against the return air. The enthalpy control will use the fresh outdoor air to reduce the indoor air conditioning cooling load to save energy, especially when the outdoor dry bulb temperature drops below the return air. Maximum saving is possible when both dry bulb temperature and the latent heat content drop below the return air. This enthalpy control can work together with the economizer system, but requires an additional enthalpy controller to compare enthalpy values in order to work out the optimum switching between the economizer and enthalpy controls.

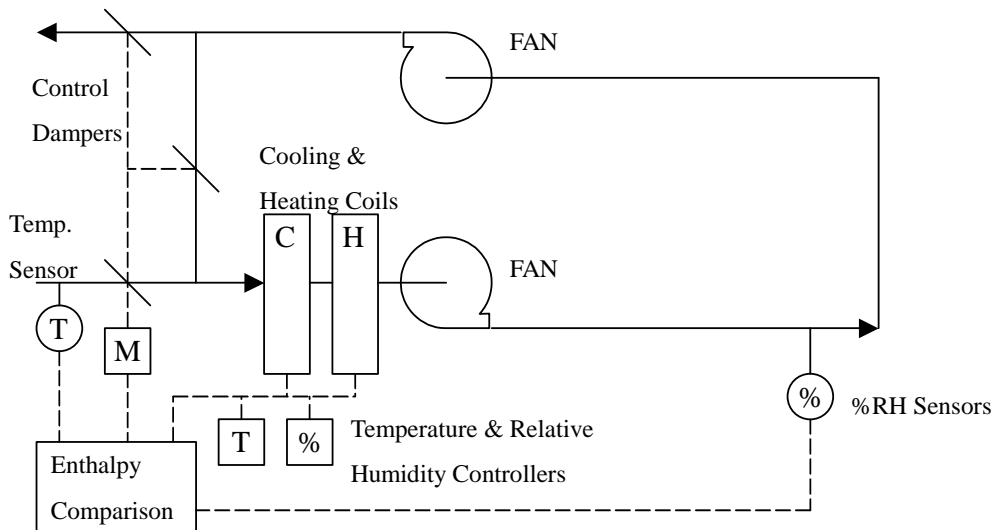

Enthalpy Control Schematic

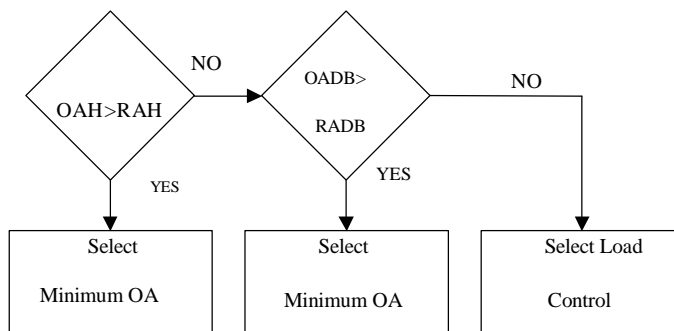

Enthalpy Decision Chart

Legend:

- OAH=Outdoor Air Enthalpy
- OA=Outdoor Air
- RADB=Return Air Dry Bulb
- RAH=Return Air Enthalpy
- OADB=Outdoor Air Dry Bulb

6.5.4 Load Reset

This program will adjust the cold and heat decks (usually the water cooling coils and heaters) temperature resets in accordance with the cooling and heating loading requirements. Previous studies indicated that the electricity bill could be reduced by 12% to 34% by merely implementing an occupied thermostat setback. The software takes temperature measurements from various areas plus the cooling and heating mixing boxes or damper locations sensors, to select the largest zone loading requirement as the control criteria.

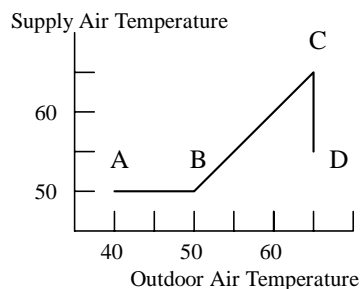

Note:

- (1) A to B: Mix Outdoor and Return Air.
- (2) B to C: 100% Outdoor Air
- (3) C to D: Economizer Cooling or Enthalpy Control

Supply Air Temperature Reset
(Single Duct VAV)

6.5.5 Duty Cycle

The program will schedule the HAVC on-off operation sequences periodically for energy saving scheme as far as indoor condition is maintained in reasonable healthy and comfortable conditions. It is not uncommon the system designers oversized the plant capacities, finally ending up with a plant continuously running and operating at its partial loadings. Hence, the plant or equipments may be switched off from time to time to save energy without too much sacrificing the comfort level, or even without the occupant's notice. ^v However, it is difficult to identify the appropriate equipment to shed, this hence requires continuous monitoring the indoor conditions, as well as the system and plant response or loading inertia, and the occupant's satisfaction and comfort index. Lighting with dimmer, occupancy sensors, and fan with variable speed drive are good examples to implement the demand shedding to limit the electrical loads. Besides, it must be stressed that this system can combine with the Optimum Start-up/Switch-Off Times method, but should not be used together with variable loading systems, such as variable volume fans, chillers, or variable capacity pumps, etc.

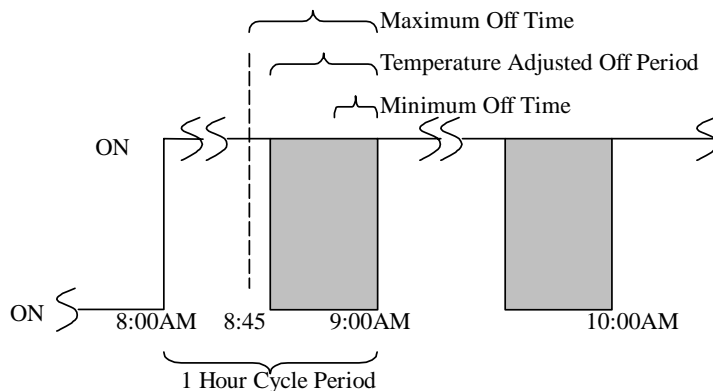

Duty Cycle Application

To ensure not to overload the equipment driver motors, it is necessary to check the on-off schedule against the manufacturer’s instruction and recommendation. Among the two most commonly used schedules of parallel and staggered duty cycling, the latter which alternates the on-off times of the motors, is usually used to assure the reliability of the motors.

6.5.6 Zero Energy Band

This program will evaluate the loading profile to identify the period when the system required no heating or cooling to maintain its indoor conditions within the acceptable range. In certain cases, it may controls the mixed-air dampers to use available outdoor air if suitable for cooling.

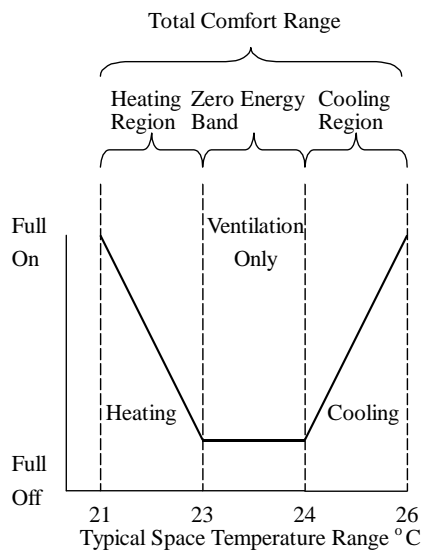

Zero Energy Band

6.5.7 Night Purge

Similar to other energy saving program, this also makes use of the outdoor air to cool down the building especially early morning before switching on the air conditioning plant or equipment. ^{VI} As much as 35% energy saving may be possible by precooling the building thermal mass with an effective control strategy. This will measure and compare the temperature, dewpoint for both outdoor and indoor air, plus the space temperature. How much amount of fresh air intake required will base mostly on the outdoor air condition, for instance, outdoor dew point of less than 15⁰C to provide 100% fresh air intake.

6.5.8 Cold-deck Temperature Control

To ensure the energy is expended to provide the comfort with maximum energy saving for the majority, this maintains the systems optimum settings for supply air supplies, according to the indoor controlled areas with maximum loads requirement.

6.5.9 Demand Limiting

This will measure and monitor the air conditioning equipments electrical power consumption and issue the commands for electrical shedding for individual equipment. A sequence schedule is initially programmed for shutting off and restarting the equipment afterwards to provide maximum energy saving and maintainability. Both client and operation teams should be consulted to workout together the shedding schedule to avoid sacrificing the occupants comfort or working performance.

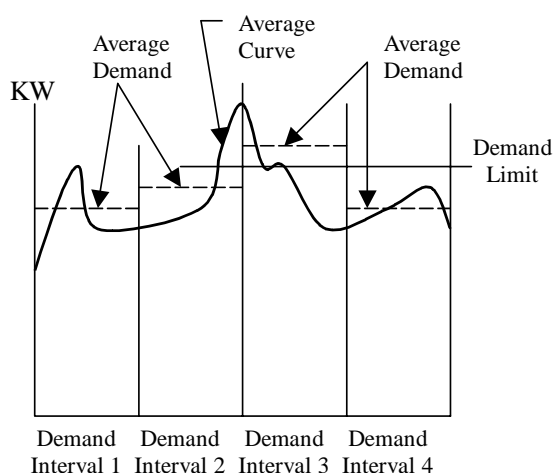

Typical Power Curve Over Four Successive Demand Intervals

6.5.10 Chiller Optimization

The chiller efficiency depends on the both chilled and condenser cooling water temperatures and flow rates, plus the chiller partial load performance, cooling load requirement profile. The energy saving program will measure and monitor all these variables to issue the necessary commands for starting up and switching off sequence to maintain the optimum efficiency, i.e. the maximum energy saving.

^{VII} Several operational guidelines are quoted for reference:

- Multiple chillers should be controlled to supply identical chilled water temperatures.
- For identical chillers, the condenser water flow rates should be controlled to provide identical leaving condenser water temperature.
- For chillers with different capacities but similar part-load performance, each chiller should be loaded at the same total load fraction.

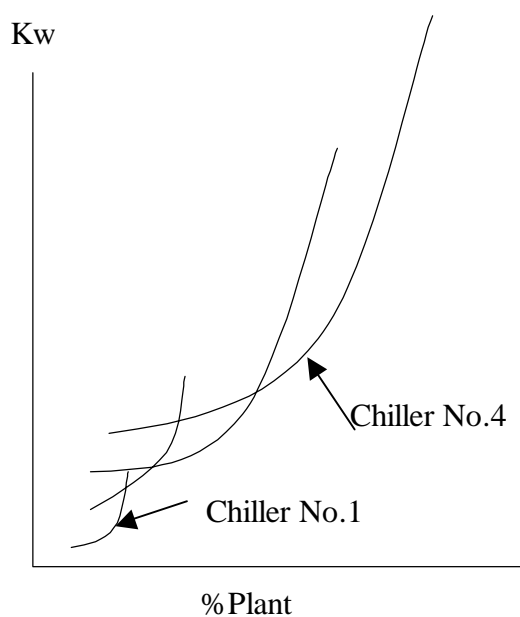

Chiller Sequencing

6.5.11 Chilled Water Temperature

Raising the chilled water temperature will usually help reduce the chiller plant energy consumption. The program will measure the system cooling load requirement and raise

the chilled water circuit temperature setting in steps to enable the optimum energy saving of the chillers and circulation pumps operations. Usually the water pumps energy saving may be offset by raising the chilled water temperature, hence requiring more closely monitoring on the overall system performance and efficiency, not just merely focusing on certain particular equipment or machinery.

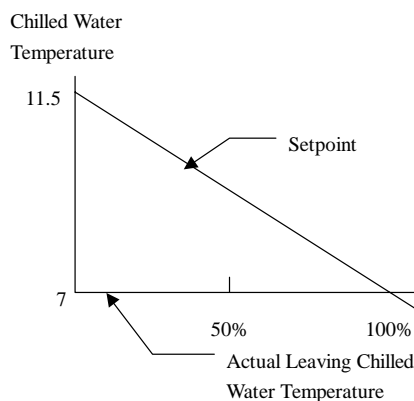

**Load Reset For
Increased Efficiency**

7. Inter-action between Systems

It is always true that adjustment of system capacity to suit loading condition can lead to system running at better energy efficiency, in a way that the system can predict the change in loading condition instead of response to the fed back loading condition.

Examples of predictable changes in loading conditions are:-

- Reduction in HVAC demand due to temporary suspension of usage, e.g. renovation work, at certain floors of a building.
- In buildings like hotels where the occupancy fluctuates a lot throughout a year, determination of cooling load demand on the chiller plants and the fresh air demand shall take into account such factors and an optimum starting sequence shall be determined accordingly.
- During off-peak hours, some lifts will be selected to standby mode. Further energy savings can be achieved by reducing the ventilation in the lift machine room as well. This is also an example that lift system interacts with HVAC system.

Adequate of A/C and lift services should be provided whenever there are activities

carried out in the function room of a hotel where occupancy increase abruptly in a short moment.

7.1 Air-conditioning systems

Air-conditioning systems are supposed to be the one greatly affected by other energy consuming systems in buildings. This is because most of the energy consumed by other systems will eventually become heat and need to be carried away by the air-conditioning or ventilation systems. A quick response air-conditioning system shall prepare its capacity for catering the coming load demand or cut down its capacity for diminishing demand. This would require a prediction on the demand and, of course, this can be obtained via the trend logging function of a CCMS. Alternatively, a more precise forecast on load demand can be obtained from direct on-line measurement on the loading condition. This is considered better because any poor control outcome due to thermal inertia or time lag in the control function can be avoided.

Installation of occupancy sensors can help to detect which area is not being occupied and all the building services provision can be switched off for that particular area. Not just because cooling in that area is no longer required, instead heat produced by other services such as lighting will also be reduced. Capacity of chiller plants can be adjusted more accurately to achieve a better energy efficiency if signals of these occupancy sensors are linked to the system.

7.2 Lighting system

The main purpose of a lighting system is to provide sufficient illuminance for use by the tenants. For system without dimming, the only way to adjust the output of lighting is perhaps by switching off some of the lamps. By doing so, tenant may have a wrong perception that the lamps are faulty. This is not recommended and there is not much to do to improve energy efficiency.

For dimmable systems with fine adjustment of light output, there are more that can be done to avoid over provision in illuminance. First of all, lamp luminance output is temperature sensitive and correction will be done automatically by the dimming circuit.

Secondly, should daylight be available, it shall be used as much as possible as they are free. A good energy efficiency lighting system shall make full use of daylight by dimming

down the artificial lighting.

7.3 Electrical System

The criteria for maintaining an optimum energy efficiency for an electrical distribution system is that:-

- transformers not in use shall be switched off at their supply side (i.e. HV side) if possible for cutting down the transformer core losses.
- load shall be shared by all supply transformers as evenly as possible for reducing transformer winding copper loss.

These criteria are contradicting with one another as the former would favour lesser transformers to be in service while the latter would support to turn on all transformers with lighter load shared among them. In fact, different loading conditions have to maintain different number of transformers in service for attaining maximum energy efficiency.

This may not be so significant as we are practically not allowed to switch off any supply transformer provided by the utility company. However, there are some rare cases that can be possibly done when the supply transformers are exceptionally provided by the building owner him selves,. As such, we are only able to manipulate the winding copper loss by evenly distributing the loading among the supply transformers.

Should the above criteria be well considered at the design stage, no further subsequent control in this aspect is required. However, a few years after occupation, the loading on each transformer may change and will no longer be so evenly distributed at long terms.

CCMS can assist to improve the situation by retrieving the loading pattern on each supply transformer and determine an optimum combination of load on each of them. As a consequence, cable diversion to other switchboards may then be required.

With the assistance of the Internet facilities, it is possible for the facility user to tailor-monitor the system to generate various types of real-time data, periodic reports, alarm alerts, etc, to enhance both the facilities maintenance and energy saving. These include the variation of voltage and current trends and ranges, transient occurrences, and harmonic parameters, statistical analysis, graphs, trends and regression reports, etc.

7.4 Lift system

Lift system will have a heavy direct impact on the electrical supply system as the power demand fluctuates greatly with the frequent lift acceleration and the continuously changing loading conditions. During peak hours, all lifts will be running without break. Other than those hours, the demand will usually be much relaxed and some of the lift cars may be selected to parking mode. With the reduction in number of lifts in services, the ventilation in the lift machine room will be reduced accordingly.

When lift cars are in parking mode, the associated lighting at the lift lobby of each floor can also be switched OFF if it is considered effective in saving energy.

Escalator system also interacts with electrical supply system. When energy consumption optimizer for escalators is installed, current demand on the electrical system will be reduced and power factor will be improved, during light load period.

More sophisticated energy efficient installation for escalator / traveller may have proximity sensors for starting system on demand. Furthermore, the lighting provision around the escalators or travellers can be designed such that they are also switched ON when on demand.

Heat generated from escalators is required to be carried away by the air-conditioning system. When determining the instantaneous cooling capacity required, full operation of all escalators is assumed. A more realistic prediction on the cooling demand shall consider any suspension of operation due to maintenance and forced outage.

7.5 Integrated design

Correct sizing of systems for achieving maximum efficiency both at full load and part load conditions, is an important procedure in designing building services systems. Traditionally, plant sizing is done by adding all the loading together and multiplying a certain safety margin of value greater than unity. For instance, chiller plants are usually sized to meet the total of maximum solar heat gain, maximum sensible heat gain and maximum latent heat required in the building, based on the design criteria.

Integrated design takes one step forward by considering the variation in loading condition and provides the best overall performance. Diversity in system demand is well

considered and a proper diversity factor of value less than unity will be applied to determine the system capacity should it be considered appropriate. The system is then divided into units so as to cater for the daily load pattern or even annual load pattern. Integrated design will consider all possible variations of loading together with the efficiency curve of different unit sizes and determine the optimum combination of unit number and rating. Of course, all other operation and maintenance factors are needed to be well considered before finalising the size of units.

With integrated design, systems are supposed to run as efficiently as possible all the time by switching IN or OUT suitable units to cope with current loading condition. However, current loading condition is usually fed back by measuring some indirect parameters or because of system inertia and long lag time in sensor response, such fed back information may not truly reflect current loading condition. Hence, even fast response systems could never cope with the dynamic demand accurately and effectively enough.

The situation can be improved if a moderately accurate prediction on the loading condition is available or a direct parameter, that represents the current loading condition, is measured. Prediction of coming loading can be made possible by the trend logging function of a CCMS if loading fluctuation is not so dynamic.

Since sharing of information easily among different systems is crucial for the success of integrated design, employing CCMS can assist to provide these flexible communication channels, in particular, if open protocol is being used.

^I Reduction of current from 1 p.u. to 0.85 p.u. (equivalent to improving power factor from 0.85 to 1) will lead to a reduction in copper loss from 12 to 0.852 and is a reduction of $(12-0.852) \times 100\%$, i.e. 27.75%

^{II} Moncef Krarto, *Energy Audit of Building Systems An Engineering Approach*, CRC Press, 2000

^{III} Honeywell: Engineering Manual of Automatic Control, SI Edition, for commercial Building Heating Ventilation, Air Conditioning

^{IV} refer to II

^V refer to II

^{VI} refer to II

^{VII} refer to II