

Guidelines on

Energy Efficiency of Electrical Installations

2007 EDITION

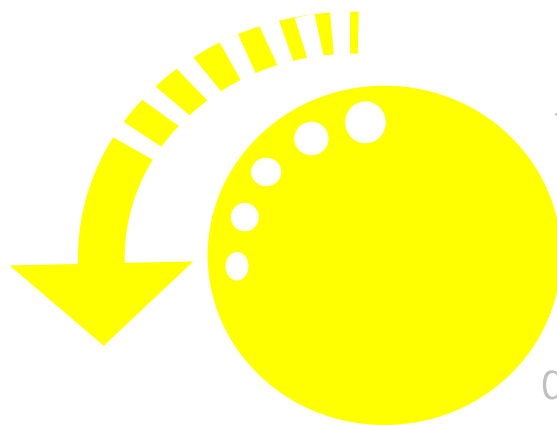

the
Supplement
to the
Code
document

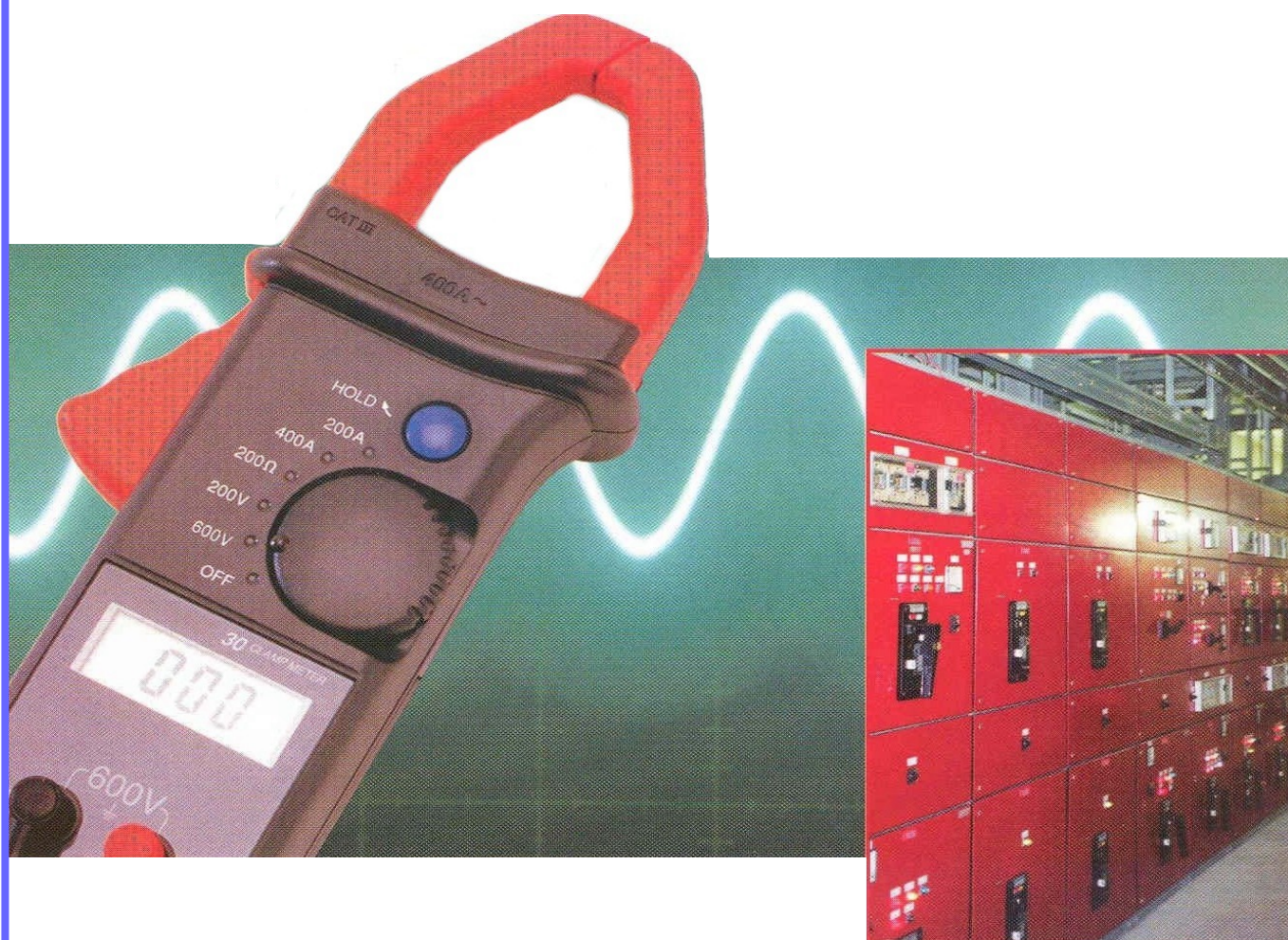

EMSD



Preface

The Code of Practice for Energy Efficiency of Electrical Installations (Electrical Code) developed by the Electrical & Mechanical Services Department (EMSD) aims to set out the minimum design requirements on energy efficiency of electrical installations. It forms a part of a set of comprehensive *Building Energy Codes (BEC)* that addresses energy efficiency requirements in building services installations. The set of comprehensive BEC covers the Electrical Code, the Codes of Practice for Energy Efficiency of Lighting Installations, Air Conditioning Installations, and Lift & Escalator Installations, and the Performance-based Building Energy Code.

As a supplement to the Electrical Code, the EMSD has developed this handbook of Guidelines on Energy Efficiency of Electrical Installations (Guidelines). The intention of the Guidelines is to provide guidance notes to compliance with the Electrical Code and draw attention of electrical installations designers & operators to generally recommended practices for energy efficiency and conservation on the design, operation & maintenance of electrical installations. The Guidelines seek to explain the requirements of the Electrical Code in general terms and should be read in conjunction with the Electrical Code. It is hoped that designers will not only design installations that would satisfy the minimum requirements stated in the Electrical Code, but also pursue above the minimum requirements.

The Guidelines were first published in 1998. With the earlier upgrade of the Electrical Code, addenda for the Guidelines were issued in 2003 & 2005 respectively. The Guidelines are amended in 2007 to suit the 2007 edition of the Electrical Code.

To promote the adoption of the BEC, the Hong Kong Energy Efficiency Registration Scheme for Buildings was also launched. The Registration Scheme provides the certification to a building complying with one or more of the BEC.

This book of Guidelines is copyrighted and all rights (including subsequent amendments) are reserved.

The Building Energy Codes, corresponding Guidelines and Registration Scheme documents are available for download at

<http://www.emsd.gov.hk/emsd/eng/pee/eersb.shtml>

Enquiry: hkeersb@emsd.gov.hk

CHECK WEB-SITE FOR LATEST INFORMATION

CONTENTS

1. INTRODUCTION	1
2. SCOPE	1
3. GENERAL APPROACH	2
4. ENERGY EFFICIENCY REQUIREMENTS FOR POWER DISTRIBUTION IN BUILDINGS	2
4.1 High Voltage Distribution	2
4.2 Minimum Transformer Efficiency	3
4.3 Locations of Distribution Transformers and Main LV Switchboard	4
4.4 Main Circuits	4
4.5 Feeder Circuits	6
4.6 Sub-main Circuits	9
4.7 Final Circuits	14
5. REQUIREMENTS FOR EFFICIENT UTILISATION OF POWER	17
5.1 Lamps and Luminaires	17
5.2 Air Conditioning Installations	17
5.3 Vertical Transportation	17
5.4 Motors and Drives	18
5.4.1 Motor Efficiency	18
5.4.2 Motor Sizing	19
5.4.3 Variable Speed Drive	20
5.4.4 Power Transfer Device	22
5.5 Power Factor Improvement	22
5.6 Other Good Practice	24
5.6.1 Office Equipment	24
5.6.2 Electrical Appliances	25
5.6.3 Demand Side management	25
6. ENERGY EFFICIENCY REQUIREMENTS FOR POWER QUALITY	26
6.1 Maximum Total Harmonic Distortion (THD) of Current on LV Circuits	26
6.2 Balancing of Single-phase Loads	30
7. REQUIREMENTS FOR METERING AND MONITORING FACILITIES	32
7.1 Main Circuits	32
7.2 Sub-main and Feeder Circuits	33
8. ENERGY EFFICIENCY IN OPERATION & MAINTENANCE OF ELECTRICAL INSTALLATIONS IN BUILDINGS	33
8.1 Emergency Maintenance	33
8.2 Planned Maintenance	33
8.3 Purpose of Maintenance	34
8.4 Economic and Energy Efficiency of Maintenance	34

1. INTRODUCTION

Electricity is the most common and popular form of energy used in all types of buildings including residential, commercial and industrial. However, through inappropriate design of the power distribution systems and misuse of electrical equipment in buildings, it also costs us dearly in terms of losses as far as energy efficiency is concerned.

The primary objective of the Code of Practice for Energy Efficiency of Electrical Installations (Electrical Code), published by the Electrical and Mechanical Services Department (EMSD), is to set out the minimum energy-efficient design standards for electrical installations without imposing any adverse constraint on building functions, nor hindrance to comfort or productivity of the building occupants. The Guidelines on Energy Efficiency of Electrical Installations (Guidelines) is a supplement to the Electrical Code. The intention of the Guidelines is to explain the principles behind relevant requirements in the Electrical Code and provide guidance on Code compliance. The Guidelines also provide the recommended general practices for energy efficiency and conservation on the design, operation & maintenance of electrical installations. Whilst focusing on energy efficiency aspects, the Guidelines are not to provide a comprehensive set of guidance notes in design of electrical installations.

The Electrical Code's requirements are "minimum" performance standards only, and designers should not rely on them but try to exceed these standards in their designs.

The Guidelines outlines and explains the provision of those clauses in the Electrical Code in simple terms together with design examples and calculations. It aims to impress upon both electrical engineers in design and operation of buildings the importance of taking adequate energy conservation measures for compliance with the Electrical Code and to guard against unnecessary energy losses in the distribution and utilisation of electrical energy.

The Guidelines should be read in conjunction with the other Codes of Practice on Lighting, Air Conditioning, and Lift & Escalator, etc., EMSD's Code of Practice for the Electricity (Wiring) Regulations and power companies' Supply Rules, in which some data and information are referred and used.

2. SCOPE

2.1 The Electrical Code shall apply to all electrical systems other than those used as emergency systems, for all new buildings except those specified in Item 2.2, 2.3 and 2.4 below.

2.2 The following types of buildings are not covered in the Code :

- (a) buildings with a total installed capacity of 100A or less, single or three-phase at nominal low voltage; and
- (b) buildings used solely for public utility services such as power stations, electrical sub-stations, and water supply pump houses etc.

2.3 Buildings designed for special industrial process may be exempted partly or wholly from the Code subject to approval of the Authority.

2.4 Equipment supplied by the public utility companies (e.g. HV/LV switchgear, transformers, cables, extract fans etc.) and installed in consumers' substations will not be covered by the Code.

- 2.5 In case where the requirements of the Code are in conflict with the requirements of the relevant Building Ordinance, Supply Rules, or Regulations, the requirements of this Code shall be superseded. This Code shall not be used to circumvent any safety, health or environmental requirements.

3. GENERAL APPROACH

- 3.1 The Code sets out the minimum requirements for achieving energy efficient design of electrical installations in buildings without sacrificing the power quality, safety, health, comfort or productivity of occupants or the building function.
- 3.2 As the Code sets out only the minimum standards, designers are encouraged to design energy efficient electrical installations and select high efficiency equipment with energy efficiency standards above those stipulated in the Code.
- 3.3 The requirements for energy efficient design of electrical installations in buildings are classified into the following four categories:
- (a) Minimising losses in the power distribution system.
 - (b) Reduction of losses and energy wastage in the utilisation of electrical power.
 - (c) Reduction of losses due to power quality problems.
 - (d) Appropriate metering and monitoring facilities.

4. ENERGY EFFICIENCY REQUIREMENTS FOR POWER DISTRIBUTION IN BUILDINGS

4.1 High Voltage Distribution

The Code requires that high voltage (HV) distribution systems should be employed for high-rise buildings to suit the load centres at various locations. A high-rise building is defined as a building having more than 50 storeys or over 175 m in height above ground level.

The number of modern air-conditioned high-rise office buildings in Hong Kong is increasing rapidly during the past decade. Following the release of height restriction in certain areas after the opening of the new Hong Kong International Airport at Chek Lap Kok in 1998, it is expected that the growth of high-rise buildings will continue to boom.

The electrical demand of a modern high-rise office building could reach well over 200 VA/m² depending on the nature of the business type and services provided. Some of these electrical loads will be concentrated in basement, intermediate mechanical floor, or rooftop plant rooms for the accommodation of chiller plant, pump sets, air handling units, lift machinery, etc. Other loads, such as landlord/tenants lighting and small power, will be evenly distributed throughout the building floors.

These high-rise buildings, with their large demand requirements, will normally have at least one HV intake, usually at 11kV, provided by the power company. The distribution (copper) losses within the building can be kept to a minimum if large block of power can be distributed at HV to load centres at various locations of the building. As the substation is sited at the centre of its load, the loss and voltage drop in the LV distribution system will be minimised. The cost may also be significantly cheaper than an all LV system due to less copper mass required.

It should be noted that the HV distribution cables are defined as Category 4 circuits under The Electricity (Wiring) Regulations. Separate cable ducts and riser ducts, segregated from cables of all other circuits categories, must be provided for HV cable distribution within the buildings.

A typical SF6 gas sealed type 1500 kVA 3-phase 11kV/380V distribution transformers used in Hong Kong have a total weight of about 5,000kg. The transportation of these distribution transformers from ground floor level to their high level substations in a high-rise building might therefore pose a major problem.

4.2 Minimum Transformer Efficiency

The Code requires that the privately owned distribution transformers should be selected to optimise the combination of no-load, part-load and full-load losses without compromising operational and reliability requirements of the electrical system. The transformer should be tested in accordance with relevant IEC standards and should have a minimum efficiency shown in Table 4.1 at the test conditions of full load, free of harmonics and at unity power factor.

TABLE 4.1: Minimum Transformer Efficiency

Transformer Capacity	Minimum Efficiency
< 1000kVA	98%
≥ 1000kVA	99%

Transformers can be manufactured with efficiencies as high as 98% to 99%. Most transformer manufacturers offer a variety of loss designs with associate differences in cost. Transformer losses are determined at 100% load and at a winding temperature of 85°C or 75°C depending on the type of transformer (e.g. SF6 gas sealed dry type and silicone fluid type). The winding (copper) loss varies approximately as the square of the load current (and varies slightly with the operating temperature). The no-load (core) loss is more or less steady (fundamental value) at constant voltage and frequency.

For privately owned distribution transformers, an efficiency of not less than 98% at full load conditions, free of harmonics and at unity power factor, is required by the Code. The transformers should be tested in accordance with BS EN 60076. Utility owned transformers are exempted from the requirement of the Code.

IEEE paper C57.110, entitled "IEEE Recommended Practice Establishing Transformer Capacity When Supplying Non-sinusoidal Load Currents", details two methods for de-rating distribution transformers as a result of the additional heating effect that occurs when these transformers supply power loads that generate a specific level of harmonics. K-factor is a method of calculation, derived from the IEEE paper, used to determine the heating impact of a non-linear load on a transformer. The K-factor is defined as the sum of the squares of the per unit harmonic current times the harmonic number squared. In equation form, the K-factor is defined as:

$$K = \sum (I_{h(\text{pu})})^2 h^2$$

where $I_{h(\text{pu})}$ is the harmonic current expressed in per unit and h is the harmonic number.

A K-rated transformer is one that is specially designed to operate at its design temperature while supplying a load that generates a specific level of harmonics. K-rated transformers are tested in according to IEEE C57.110 by the manufacturer, and then assigned a "K" rating. Typical ratings are K-4, K-9, K-13, K-15, K-20, etc.

More details on transformer losses due to harmonics could be found in section 6.1 of this guide.

4.3 Locations of Distribution Transformers and Main LV Switchboard

The Code requires that the locations of distribution transformers and main LV switchboards shall preferably be sited at their load centres rather than at the periphery of the buildings, provided that all local supply rules and fire regulations etc. could also be complied with.

Traditional location of a transformer room in a building is normally at the ground floor level with an appropriate vehicular access for loading and unloading substation equipment. The main LV switchroom is normally located adjacent to the transformer room and all sub-main and feeder circuits including the rising mains will be fed from the main LV switchboard. Distribution losses and cost for electrical loads at roof level and far away from the main LV switchboard are usually high.

Mechanical floors are normally incorporated in the design of modern high-rise commercial buildings at intermediate levels where all major electrical and mechanical plant rooms are located. Transformers and main LV switch rooms could be provided on these floors to minimise LV distribution losses. Problems need to be considered include separate cable ducts provision for HV (11 kV) cables, vertical transportation for transformers (normally single-phase type to reduced size and weight) and switchgear, fire protection and EMI problems to adjacent floors etc. Substations sited other than at ground floor locations must be equipped with non-flammable equipment to satisfy FSD requirements, e.g. SF6 or vacuum circuit breaker, SF6 or silicone-fluid filled transformers and LSF/XLPE cables etc.

4.4 Main Circuits

The Code requires that the copper loss of every main circuit connecting the distribution transformer and the main incoming circuit breaker of a LV switchboard should be minimised by means of either:

- (a) locating the transformer room and the main switchroom immediately adjacent to, above or below each other, or
- (b) restricting its copper loss to not exceeding 0.5% of the total active power transmitted along the circuit conductors at rated circuit current.

The cross-sectional area of neutral conductors should not less than that of the corresponding phase conductors.

In any electrical circuit some electrical energy is lost as heat which, if not kept within safe limits, may impair the performance and safety of the system. This energy (copper) loss, which also represents a financial loss over a period of time, is proportional to the effective resistance of the conductor, the square of the current flowing through it and the duration of operational time. A low conductor resistance therefore means a low energy loss; a factor of increasing importance as the energy efficiency and conservation design is concerned.

The length of the main distribution circuit conductors connecting the distribution transformer and the main incoming circuit breaker (MICB) of the LV switchboard should be as short as possible by means of locating the substation and the main LV

Guidelines on Energy Efficiency of Electrical Installations, 2007

switchroom adjacent to each other. A maximum conductor length of 20m is recommended which is based on utility's guide to connection of supply.

Due to the possibility of large triplen harmonic currents existing in the neutral conductor for building loads with a large proportion of non-linear equipment, it is not recommended to use neutral conductors with a cross-sectional area less than that of phase conductors in the main circuit.

Typical sample calculations for various wiring systems used for a main circuit feeding from a 1500kVA 11kV/380V 3-phase distribution transformer to a main LV switchboard having a circuit length of 20m are provided as follows:

1. 2500A 4-wire copper insulated busduct system
2. 3x630mm² 1/C XLPE copper cables for each phase and neutral in cable trench
3. 3x960mm² 1/C XLPE aluminium cables for each phase and neutral in cable trench

Assuming a balanced and undistorted full load design current of 2280A at a power factor of 0.85, the power loss in transferring the power in each case is calculated.

Total active power transferred = 1500 x 0.85 = 1275kW

Case (1) : 2500A 4-wire copper busduct system

Resistance per conductor, $r = 0.0177\text{m}\Omega/\text{m}$ at 80°C (Based on common busduct)

Total power losses = $3 \times 2280^2 \times 0.0000177 \times 20 = 5.52\text{kW}$ (0.433%)

Case (2) : 3x630mm² 1/C XLPE copper cables for each phase and neutral in cable trench as shown below

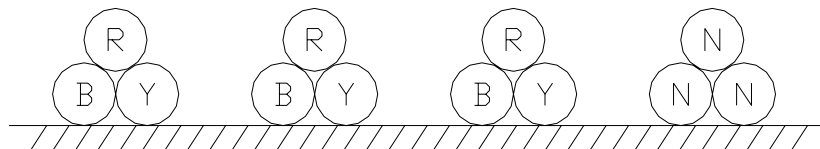

Resistance per conductor (Based on BS7671, Table 4E1B) = $0.074/\sqrt{3} = 0.043\text{ m}\Omega/\text{m}$ (at 90°C)

Effective resistance per phase with 3 conductors in parallel = $0.043/3\text{ m}\Omega/\text{m} = 0.0143\text{ m}\Omega/\text{m}$

Total power losses = $3 \times 2280^2 \times 0.0000143 \times 20 = 4.46\text{kW}$ (0.35%)

Case (3) : 3x960mm² 1/C XLPE aluminium cables for each phase and neutral

Resistance per conductor (Based on BS7671, Table 4L1B) = $0.082/\sqrt{3} = 0.0473\text{ m}\Omega/\text{m}$ (at 90°C)

Effective resistance per phase with 3 conductors in parallel = $0.0473/3\text{ m}\Omega/\text{m} = 0.0158\text{m}\Omega/\text{m}$

Total power losses = $3 \times 2280^2 \times 0.0000158 \times 20 = 4.93\text{kW}$ (0.387%)

For design purpose, the examples above provide a quick guideline for main circuit design using different types of conductors up to 20m in length. All three cases above can fulfil the requirement of maximum power loss of 0.5% under full load, balanced and undistorted conditions. Designers should ensure adequate precautions have been taken in balancing the loads and harmonic reduction in the design of main circuits.

Main circuits designed, supplied and installed by the utility companies are exempt from the requirement of the Code.

4.5 Feeder Circuits

A feeder circuit is defined as a circuit connected directly from the main LV switchboard to the major current-using equipment such as chiller plant, pump sets and lift system. The code requires that the maximum copper loss in every feeder circuit should not exceed 2.5% of the total active power transmitted along the circuit conductors at rated circuit current. This requirement does not apply to circuits used for compensation of reactive and distortion power.

For a 3-phase circuit with balanced and linear load, the apparent power transmitted along the circuit conductors in VA is:

$$S = \sqrt{3}U_L I_b$$

Active power transmitted along the circuit conductors in W is:

$$P = \sqrt{3}U_L I_b \cos \theta$$

Total copper losses in conductors in W is:

$$P_{copper} = 3 \times I_b^2 \times r \times L$$

where U_L = Line to line voltage, 380V

I_b = Design current of the circuit in ampere

$\cos \theta$ = Displacement power factor of the circuit

r = a.c. resistance per metre per conductor at the conductor operating temperature

L = Length of the cable in metre

Percentage copper loss with respect to the total active power transmitted,

$$\% \text{ loss} = \frac{3 \times I_b^2 \times r \times L}{\sqrt{3}U_L I_b \cos \theta}$$

This maximum copper loss requirement is deemed to comply with for any 3-phase balanced circuit with linear characteristic, if feeder circuits are designed to the conventional safety requirement of the Electricity (Wiring) Regulations.

The conventional method of cable sizing can briefly be described as follows:

The relationship among circuit design current (I_b), nominal rating of protective device (I_n) and effective current-carrying capacity of conductor (I_z) for an electrical circuit can be expressed as:

Co-ordination among I_b , I_n & I_z : $I_b \leq I_n \leq I_z$

Calculated minimum tabulated value of current: $I_t(\text{min.}) = I_n \times \frac{1}{C_a} \times \frac{1}{C_g} \times \frac{1}{C_i}$

Effective current-carrying capacity: $I_z = I_t \times C_a \times C_g \times C_i$

Guidelines on Energy Efficiency of Electrical Installations, 2007

Where I_t = the value of current tabulated in Appendix 4 of BS7671, Requirements for Electrical Installations

C_a = Correction factor for ambient temperature

C_g = Correction factor for grouping

$C_{i=}$ = Correction factor for thermal insulation

A work example on feeder cable sizing is given as below:

A 380 V 3-phase feeder circuit to a 40kW sea water pump set is wired in a 4-core PVC/SWA/PVC copper cable. The cable is mounted on a perforated cable tray with 2 other similar cables touching. The steel wire armour of the cable is to be used as circuit protective conductor. HRC fuses to BS88 are to be used for circuit protection. Assuming the ambient-air temperature is 35°C and star/delta starter is used for motor starting. The efficiency and power factor of the motor at full load are given as 0.8 and 0.85 respectively. The length of the cable is 80 m from the main switchboard. The minimum cable size for compliance with the Electricity (Wiring) Regulations is determined as follows:

Design current of 40kW motor circuit, $I_b = 89.37$ A

HRC fuse rating selected, $I_n = 100$ A as protective devices

Correction factors $C_g = 0.94$ $C_a = 0.81$

Minimum current-carrying capacity, $I_t(\text{min.}) = 131$ A

From table 4D4A (BS7671), $I_t = 135$ A for 35mm² 4/c PVC/SWA/PVC cable

Voltage drop = $1.1 \times 89.37 \times 80 = 7.86$ V (2%)

Effective current-carrying capacity, $I_z = 135 \times 0.94 \times 0.81 = 102.8$ A

Resistance of conductor (Table 4.2A), $r = 0.625$ mΩ/m

% copper loss = $(3 \times 89.37^2 \times 0.000625 \times 80) / (40000 / 0.8) = 2.4\%$ (< 2.5%)

The minimum cable size selected is 35mm², which comply with both the safety and energy efficiency requirements.

This method is based on the assumption that the supply voltages and load currents are sinusoidal and balanced among the three phases in a 3-phase 4-wire power distribution system. However, extra care must be taken if the 3-phase feeder circuit is connected to non-linear load, such as Uninterruptable Power Supply (UPS) systems, Variable Voltage Variable Frequency (VVVF) lift drive systems and Variable Speed Drive (VSD) motor systems, etc. The design current used for cable sizing must take harmonic currents into account.

For a 3-phase non-linear circuit having known design current I_b or fundamental current I_1 and total harmonic distortion THD, the apparent power transmitted along the circuit conductors in VA is:

$$S = \sqrt{3} U_L I_b$$

$$\text{where } I_b = \sqrt{\sum_{h=1}^{\infty} I_h^2} = \sqrt{I_1^2 + I_2^2 + I_3^2 + \dots}$$

$$\text{From definition: } THD = \frac{\sqrt{\sum_{h=2}^{\infty} (I_h)^2}}{I_1}$$

$$\text{Therefore, } I_b = I_1 \sqrt{1 + THD^2}$$

And, fundamental current $I_1 = \frac{I_b}{\sqrt{1 + THD^2}}$

Assuming voltage distortion is small, $U_L = U_1$, and active power transmitted along the circuit conductors in W is given by:

$$P = \sqrt{3}U_L I_1 \cos \theta$$

where U_L = Supply line voltage at 380V

I_1 = Fundamental phase current of the circuit in ampere

$\cos \theta$ = Displacement power factor of the circuit

And, Total Power Factor = $\frac{P}{S} = \frac{\cos \theta}{\sqrt{1 + THD^2}}$

Assuming the skin and proximity effects are small, total copper losses in conductors including neutral in W is given by:

$$P_{copper} = (3 \times I_b^2 + I_N^2) \times r \times L$$

where I_N = Neutral current of the circuit in ampere

$$= 3 \times \sqrt{I_3^2 + I_6^2 + I_9^2 + \dots}$$

I_b = Design rms phase current of the circuit in ampere

r = a.c. resistance per metre at the conductor operating temperature

L = Length of the cable in metre

Percentage copper loss with respect to the total active power transmitted,

$$\% \text{ loss} = \frac{(3 \times I_b^2 + I_N^2) \times r \times L}{\sqrt{3}U_L I_1 \cos \theta}$$

Using the same work example above, if the feeder circuit is designed for VSD drive instead of the conventional star/delta starter, the new feeder circuit have to be re-designed as follows. Given that THD at full-load and full-speed condition is 80% (a figure for illustrating the harmonic effect and does not comply with Table 6.1) and harmonic components are mainly 5th and 7th order.

Fundamental current of 40kW motor circuit, $I_1 = 89.37$ A

Design current, $I_b = I_1 \sqrt{1 + THD^2} = 89.37 \sqrt{1 + 0.8^2} = 126$ A

HRC fuse rating selected, $I_n = 160$ A as protective devices

Correction factors $C_g = 0.94$ $C_a = 0.81$

Minimum current-carrying capacity, $I_t(\text{min.}) = 210$ A

From table 4D4A (BS7671), $I_t = 251$ A for 95mm² 4/c PVC/SWA/PVC cable

Voltage drop = $0.43 \times 126 \times 80 = 4.33$ V (1.1%)

Effective current-carrying capacity, $I_z = 251 \times 0.94 \times 0.81 = 191$ A

Resistance per unit length of conductor (Table 4.2A), $r = 0.235$ mΩ/m

$I_N = 0$

% copper loss = $(3 \times 126^2 \times 0.000235 \times 80) / (40000 / 0.8) = 1.8\%$ (< 2.5%)

The minimum cable size required for the new feeder circuit is 95mm², which has much smaller voltage drop and power loss.

More details on THD requirements could be found in section 6.1.

4.6 Sub-main Circuits

A sub-main circuit can be defined as a circuit connected directly from the main LV switchboard to a sub-main distribution panel or a rising main for final connection of the minor current-using equipment. The Code requires that the maximum copper loss in every sub-main circuit should not exceed 1.5% of the total active power transmitted along the circuit conductors at rated circuit current. However for domestic flats, the maximum allowable copper loss is relaxed to 2.5% to cater for the actual trade practice of minimizing the cable sizes for purpose of fitting in conduit for a lateral circuit branching-off from riser.

Similar approach could be followed for sizing conductor as feeder circuit above. However, assumption has to be made in the design for various characteristics of the sub-main circuit including design current, expected harmonic current (THD) in the circuit, degree of unbalance, etc.

Alternatively, an energy efficiency method introduced by the Code could also be used for preliminary cable sizing. This energy efficiency method for cable sizing requires the calculation of the maximum allowable conductor resistance based on the maximum copper loss requirement as stipulated in the code.

For a 3-phase 4-wire circuit (assuming balanced, linear or non-linear):

Active power transmitted via the circuit conductors, $P = \sqrt{3}U_L I_f \cos \theta$

Total copper losses in conductors, $P_{copper} = (3 \times I_b^2 + I_N^2) \times r \times L$

where U_L = Line to line voltage, 380V

I_b = Design current of the circuit in ampere

I_f = Fundamental current of the circuit in ampere

I_N = Neutral current of the circuit in ampere

$\cos \theta$ = Displacement power factor of the circuit

r = a.c. resistance / conductor / metre at the conductor operating temperature

L = Length of the cable in metre

Percentage copper loss with respect to the total active power transmitted,

$$\% \text{ copper loss} = \frac{(3 \times I_b^2 + I_N^2) \times r \times L}{P} \times 100 = \frac{(\sum I^2) \times r \times L}{P} \times 100$$

$$\text{Therefore, max. } r \text{ (m}\Omega\text{/m)} = \frac{\text{max. \% loss} \times P \times 1000}{(\sum I^2) \times L}$$

Table 4.2A and 4.2B in the Code provide a quick initial assessment of cable size required for the common cable types and installation methods used in Hong Kong.

The tabulated current rating of the selected cable could then be corrected by applying the correction factors accordingly. The effective-current carrying capacity of the selected cable must be checked so that its value is larger than or equal to the nominal rating of the circuit protective device.

Guidelines on Energy Efficiency of Electrical Installations, 2007

A work example on sub-main cable sizing under different loading characteristics is given below:

A 3-phase sub-main circuit having a design fundamental current of 100A is to be wired with 4/C PVC/SWA/PVC cable on a dedicated cable tray. Assuming an ambient temperature of 30°C and a circuit length of 40m, calculate an appropriate cable size at the following conditions:

- Undistorted balanced condition using conventional method ($\cos\theta = 0.85$);
- Undistorted balanced condition with a maximum copper loss of 1.5% ($\cos\theta = 0.85$);
- Distorted balanced condition with $I_3=33A$ & $I_5=20A$ (THD 38.6%) and a maximum copper loss of 1.5% ($\cos\theta = 0.85$);
- Circuit to feed VSD loads with harmonic current $I_5=70A$, $I_7=50A$ & $I_{11}=15A$ (THD 87%) and a maximum copper loss of 1.5% ($\cos\theta = 1$); and
- Circuit to feed 3 VSD loads as in (d).

Case (a): Undistorted balanced condition using conventional method:

$$I_b = 100A \quad I_n = 100A$$

Assume the correction factors C_a , C_p , C_g & C_i are all unity.

$$\therefore I_t(\text{min.}) = \frac{I_n}{C_a C_g C_p C_i} = 100A$$

Refer to BS7671, Requirements for Electrical Installations,
Table 4D4A 25mm² 4/C PVC/SWA/PVC cable $I_t = 110A$

Conductor operating temperature $t_1 = 30 + 100^2 / 110^2 \times (70-30) = 63^\circ\text{C}$
Ratio of conductor resistance at 63°C to 70°C = $(230+63)/(230+70) = 0.98$

Voltage drop = $1.5 \times 0.98 \times 100 \times 40 = 5.88V$ (1.55%)

Active power transferred (P) = $\sqrt{3} \times 380 \times 100 \times 0.85 = 56kW$

Total copper losses in conductors
= $3 \times 100^2 \times 0.0015 / \sqrt{3} \times 0.98 \times 40$
= 1.02kW (1.82%)

Cable size of 25mm² selected can comply with the safety requirement but is not acceptable if the maximum allowable copper loss is limited to 1.5%.

Case (b): Maximum copper loss method using Table 4.2A in the Code for initial assessment of an approximate conductor size required by calculating the maximum conductor resistance at 1.5% power loss:

$$\begin{aligned} \text{max. } r \text{ (m}\Omega\text{/m)} &= \frac{\text{max. \% loss} \times U_L \times \cos \theta \times 1000}{\sqrt{3} \times I_b \times L} \\ &= \frac{0.015 \times 380 \times 0.85 \times 1000}{\sqrt{3} \times 100 \times 40} \\ &= 0.7 \text{ m}\Omega\text{/m} \end{aligned}$$

Guidelines on Energy Efficiency of Electrical Installations, 2007

From Table 4.2A 35 mm² 4/C PVC/SWA/PVC cable having a conductor resistance of 0.625 mΩ/m is required.

Refer to BS7671, Requirements for Electrical Installations,
Table 4D4A 35mm² 4/C PVC/SWA/PVC cable $I_t = 135A$

Conductor operating temperature $t_1 = 30 + 100^2 / 135^2 \times (70-30) = 52^\circ C$
Ratio of conductor resistance at 52°C to 70°C = $(230+52) / (230+70) = 0.94$

Voltage drop = $1.1 \times 0.94 \times 100 \times 40 = 4.14V$ (1.09%)

Total copper losses in conductors = $3 \times 100^2 \times 0.625 \times 0.94 \times 40 = 716W$ (1.28%)

Cable size of 35mm² selected is acceptable for both safety and energy requirements, i.e. power loss < 1.5%, under undistorted and balanced conditions.

Case (c): Distorted balanced condition with $I_3=33A$ & $I_5=20A$ (THD 38.6%) and a maximum copper loss of 1.5%:

Fundamental current $I_1 = 100A$, harmonic currents $I_3 = 33A$ & $I_5 = 20A$

THD = $\sqrt{(33^2 + 20^2)} / 100 = 38.6\%$

$I_{rms} = I_1 \sqrt{(1+THD^2)} = 100A \sqrt{(1+0.386^2)} = 107.2A$

Neutral current (rms) $I_N = 3 \times 33A = 99A$

Let $I_n = 125A$

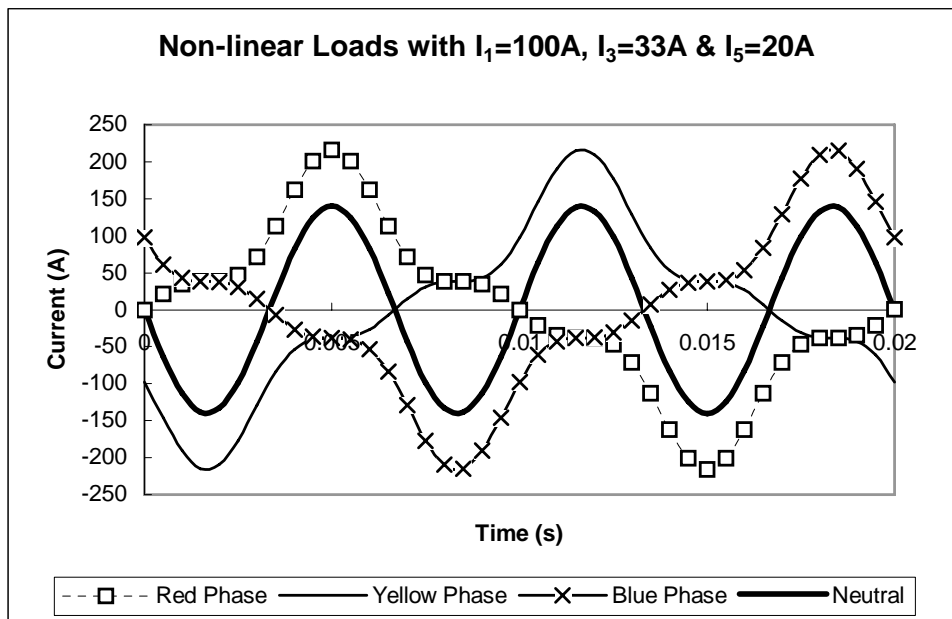

Fig. 4.1: Current Waveforms for case (c)

From case (b) above 35mm² 4/C PVC/SWA/PVC cable was selected

Refer to BS7671, Requirements for Electrical Installations,
Table 4D4A 35mm² 4/C PVC/SWA/PVC cable $I_t = 135A$

Conductor operating temperature, $t_1 = 30 + (3 \times 107.2 + 99)^2 / (3 \times 135)^2 \times (70-30) = 73^\circ C$
(Note: conductor operating temperature would be 73°C at this condition which is over the maximum of 70°C for PVC insulated cable)

Guidelines on Energy Efficiency of Electrical Installations, 2007

Ratio of conductor resistance at 73°C to 70°C = $(230+73)/(230+70) = 1.01$ (over temperature)

Total copper losses in conductors (assuming skin & proximity effects are negligible for harmonic currents) = $(3 \times 107.2^2 + 99^2) \times 0.000625 \times 1.01 \times 40 = 1.14\text{kW}$

Active power, $P = \sqrt{3} \times 380 \times 100 \times 0.85 = 56\text{kW}$
 % copper loss = $1.14 / 56 \times 100 = 2\%$ (over 1.5% max.)

Try next cable size: 50mm² 4/C PVC/SWA/PVC cable

Refer to BS7671, Requirements for Electrical Installations, Table 4D4A 50mm² 4/C PVC/SWA/PVC cable $I_t = 163\text{A}$

Conductor operating temperature,
 $t_1 = 30 + (3 \times 107.2 + 99)^2 / (3 \times 163)^2 \times (70 - 30) = 59.6^\circ\text{C}$
 Ratio of conductor resistance at 59.6°C to 70°C
 = $(230 + 59.6) / (230 + 70) = 0.965$

Total copper losses in conductors = $(3 \times 107.2^2 + 99^2) \times 0.000465 \times 0.965 \times 40 = 789\text{W}$

% copper loss = $0.789 / 56 \times 100 = 1.4\%$ (<1.5% OK)

A cable size of 50mm² is selected for compliance with both safety and energy requirements under this condition.

Case (d): Circuit to feed VSD loads with full load and full speed harmonic current $I_5=70\text{A}$, $I_7=50\text{A}$ & $I_{11}=15\text{A}$ (THD 87%) and a maximum copper loss of 1.5% ($\cos\theta = 1$)

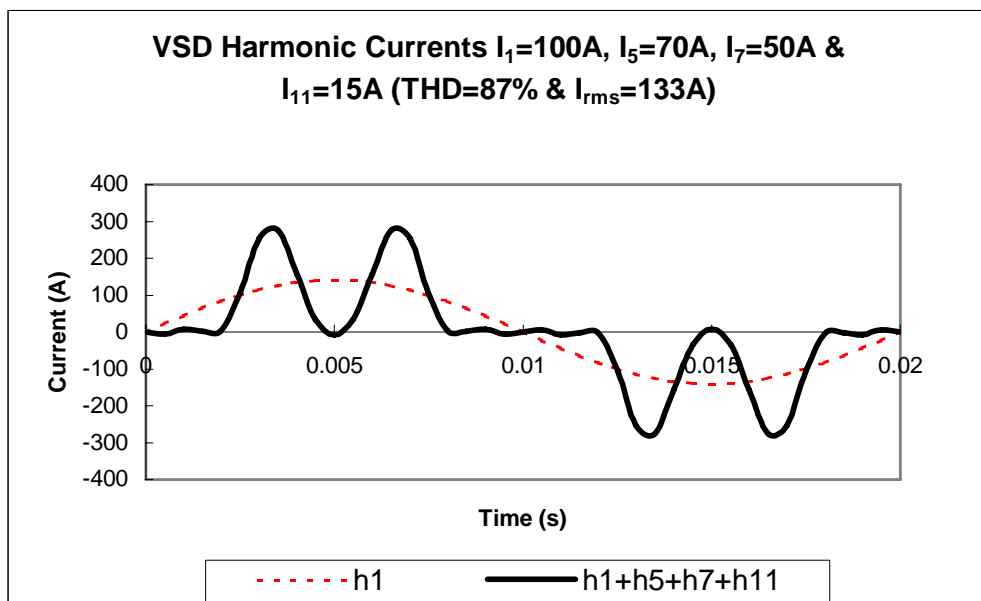

Fig. 4.2: Current Waveforms for Case (d)

Fundamental current, $I_1 = 100\text{A}$
 Harmonic currents, $I_5 = 70\text{A}$, $I_7 = 50\text{A}$ & $I_{11} = 15\text{A}$

Guidelines on Energy Efficiency of Electrical Installations, 2007

$$\text{THD} = \sqrt{(70^2 + 50^2 + 15^2)} / 100 = 87.3\%$$

$$I_{\text{rms}} = I_1 \sqrt{(1 + \text{THD}^2)} = 100\text{A} \sqrt{(1 + 0.873^2)} = 133\text{A}$$

New design current, $I_b = I_{\text{rms}} = 133\text{A}$

New rating of protective device, $I_n = 160\text{A}$

Minimum current-carrying capacity of conductors, $I_t(\text{min}) = 160\text{A}$

$$\begin{aligned} \text{Max. conductor resistance, } r &= \frac{\text{max. \% loss} \times U_L \times I_1 \times \cos \theta \times 1000}{\sqrt{3} \times I_b^2 \times L} \\ &= \frac{1.5\% \text{ loss} \times 380 \times 100 \times 1 \times 1000}{\sqrt{3} \times 133^2 \times 40} \\ &= 0.465 \text{ m}\Omega/\text{m} \end{aligned}$$

From Table 4.2A 50 mm² 4/C PVC/SWA/PVC cable having a conductor resistance of 0.465 mΩ/m is required.

Refer to BS7671, Requirements for Electrical Installations,

Table 4D4A 50mm² 4/C PVC/SWA/PVC cable $I_t = 163\text{A}$

Table 4D4B $r = 0.8\text{mV/A/m}$ $x = 0.14\text{mV/A/m}$ $z = 0.81\text{mV/A/m}$

Conductor operating temperature $t_1 = 30 + 133^2 / 163^2 \times (70 - 30) = 57^\circ\text{C}$

Ratio of conductor resistance at 57°C to 70°C = $(230 + 57) / (230 + 70) = 0.956$

$$\text{Voltage drop} = \sqrt{(0.8 \times 0.956)^2 + 0.14^2} \times 133 \times 40 = 4.14\text{V} (1.09\%)$$

$$\text{Active power drawn (P)} = \sqrt{3} \times 380 \times 100 = 65.8\text{kW}$$

Total copper losses in conductors (assuming skin & proximity effects are negligible)

$$= 3 \times 133^2 \times 0.000465 \times 0.956 \times 40$$

$$= 0.94\text{kW} (1.4\%) (<1.5\%, \text{OK})$$

A cable size of 50 mm² is selected for compliance with both safety and energy requirements under this condition.

Case (e): A riser is going to supply 3 nos. of VSDs as described in Case (d) on 13/F, 14/F and 15/F of a building. No diversity factor is to be applied.

Fundamental current, $I_1 = 300\text{A}$

5th harmonic current, $I_5 = 210\text{A}$

7th harmonic current, $I_7 = 150\text{A}$

11th harmonic current, $I_{11} = 45\text{A}$

$$\text{THD} = \frac{\sqrt{210^2 + 150^2 + 45^2}}{300} = 87.3\%$$

$$I_{\text{rms}} = I_1 \times \sqrt{1 + \text{THD}^2} = 300 \times \sqrt{1 + 0.873^2} = 300 \times 1.327 = 398\text{A}$$

Design current $I_b = 398\text{A}$

Rating of protective device, $I_n = 400\text{A}$

Min. cable current carrying capacity $I_t(\text{min}) = 400\text{A}$

Assume the floor-to-floor height is 3 m and the cable is with a horizontal run of 10m.

Actual cable length, $L' = 10 + 15 \times 3 = 55\text{m}$

$$\text{Effective cable length, } L = 10 + 13 \times 3 + \frac{2}{3} \times 3 + \frac{1}{3} \times 3 = 52\text{m}$$

Max. conductor resistance

$$\begin{aligned} &= \frac{\text{max. loss (p.u.)} \times U_L \times I_1 \times \cos \theta \times 1000}{\sqrt{3} \times I_b^2 \times L} \\ &= \frac{0.015 \times 380 \times 300 \times 1 \times 1000}{\sqrt{3} \times 398^2 \times 52} \\ &= 0.12 \text{ m}\Omega/\text{m} \end{aligned}$$

From Table 4.2A, 240 mm² 4/C PVC/SWA/PVC cable having a conductor resistance per unit length of 0.095 mΩ/m is required.

Refer to BS7671, Requirements for Electrical Installations.

Table 4D4A 240 mm² 4/C PVC/SWA/PVC cable $I_t = 445\text{A}$

Table 4D4B $r = 0.165 \text{ mV/A/m}$ $x = 0.130 \text{ mV/A/m}$ $z = 0.21 \text{ mV/A/m}$

$$\text{Conductor operating temperature } t_1 = 30 + \frac{398^2}{445^2} \times (70 - 30) = 62 \text{ }^\circ\text{C}$$

$$\text{Ratio of conductor resistance at } 62 \text{ }^\circ\text{C to } 70 \text{ }^\circ\text{C} = \frac{230 + 62}{230 + 70} = 0.973$$

$$\begin{aligned} \text{Voltage drop} &= \sqrt{(0.165 \times 0.973)^2 + 0.13^2} \times 398 \times 52 \\ &= 0.2066 \times 398 \times 52 \\ &= 4.276 \text{ V (1.13\%)} \end{aligned}$$

$$\text{Active power drawn} = \sqrt{3} \times 380 \times 300 \times 1 = 197.5\text{kW}$$

$$\begin{aligned} \text{Total copper losses in conductors (assuming skin \& proximity effects are negligible)} \\ &= 3 \times 398^2 \times 0.000095 \times 0.973 \times 52 \\ &= 2284\text{W (1.16\% < 1.5\%)} \end{aligned}$$

A cable size of 240 mm² is selected for compliance with both safety and energy efficiency requirements under this condition.

4.7 Final Circuits

A final circuit is defined as a circuit connected directly from a sub-main panel (distribution board) to current using equipment, or to a socket-outlet or socket-outlets or other outlet points for the connection of such equipment. The Code requires that the maximum copper loss for every single-phase or three-phase final circuit over 32A should not exceed 1% of the total active power transmitted along the circuit conductors at rated circuit current.

This requirement excludes most standard final circuits below 32A rating for lighting, socket outlet and small power distribution in buildings in which minimum conductor size is specified in the Electricity (Wiring) Regulation. However, designers are required to ensure that the standard final circuits (A1 ring, A2 radial and A3 radial) using 13A socket outlets, as stated in Clause 6C of the Code of Practice for the Electricity (Wiring) Regulations, should be as short as possible by locating the MCB distribution board at the proximity of the areas served by the circuit.

Table 4.2A & 4.2B in the following pages are given to provide guidance for preliminary selection of appropriate cable size for main, feeder, sub-main and final circuits based on the maximum allowable resistance value for a certain percentage copper loss.

TABLE 4.2A

Multicore Armoured and Non-armoured Cables (Copper Conductor)

Conductor Resistance at 50 Hz Single-phase or Three-phase a.c.

(Based on BS7671, Requirements for Electrical Installations, Table 4D2B, 4D4B, 4E2B & 4E4B)

Conductor cross-sectional area (mm ²)	Conductor resistance for PVC and XLPE cable in milliohm per metre (mΩ/m)	
	PVC cable at max. conductor operating temperature of 70°C	XLPE cable at max. conductor operating temperature of 90°C
1.5	14.5	15.5
2.5	9	9.5
4	5.5	6
6	3.65	3.95
10	2.2	2.35
16	1.4	1.45
25	0.875	0.925
35	0.625	0.675
50	0.465	0.495
70	0.315	0.335
95	0.235	0.25
120	0.19	0.2
150	0.15	0.16
185	0.125	0.13
240	0.095	0.1
300	0.0775	0.08
400	0.0575	0.065

Guidelines on Energy Efficiency of Electrical Installations, 2007

TABLE 4.2B

Single-core PVC/XLPE Non-armoured Cables, with or without sheath (Copper Conductor)

Conductor Resistance at 50 Hz Single-phase or Three-phase a.c.

(Based on BS7671, Requirements for Electrical Installations, Table 4D1B & 4E1B)

Conductor cross-sectional area (mm ²)	Conductor resistance for PVC and XLPE cable in milliohm per metre (mΩ/m)			
	PVC cable at max. conductor operating temperature of 70°C		XLPE cable at max. conductor operating temperature of 90°C	
	Enclosed in conduit/trunking	Clipped direct or on tray, touching	Enclosed in conduit/trunking	Clipped direct or on tray, touching
1.5	14.5	14.5	15.5	15.5
2.5	9	9	9.5	9.5
4	5.5	5.5	6	6
6	3.65	3.65	3.95	3.95
10	2.2	2.2	2.35	2.35
16	1.4	1.4	1.45	1.45
25	0.9	0.875	0.925	0.925
35	0.65	0.625	0.675	0.675
50	0.475	0.465	0.5	0.495
70	0.325	0.315	0.35	0.34
95	0.245	0.235	0.255	0.245
120	0.195	0.185	0.205	0.195
150	0.155	0.15	0.165	0.16
185	0.125	0.12	0.135	0.13
240	0.0975	0.0925	0.105	0.1
300	0.08	0.075	0.0875	0.08
400	0.065	0.06	0.07	0.065
500	0.055	0.049	0.06	0.0525
630	0.047	0.0405	0.05	0.043
800	-	0.034	-	0.036
1000	-	0.0295	-	0.0315

5. REQUIREMENTS FOR EFFICIENT UTILISATION OF POWER

5.1 Lamps and Luminaires

The Code requires that all lamps and luminaires forming part of an electrical installation in a building should preferably comply with the Code of Practice for Energy Efficiency of Lighting Installations. The booklet "Guidelines on Energy Efficiency of Lighting Installations" published by EMSD is also available for designers to obtain more information and guidance on efficient lighting design and operation.

As the energy used for general lighting contributes almost 25% of the total energy consumption of a modern commercial building, it is a major area to be considered as far as energy efficiency and conservation is concerned. Designers are encouraged to adopt the new technology developed in the lighting industry. The latest development include T8 high frequency fluorescent lamps, T5 fluorescent lamps, compact fluorescent lamps, electronic ballasts (dimmable and non-dimmable types) for controlling fluorescent lamps, lighting control using photocell and occupancy sensors, etc.

All lighting circuits are preferably fed from dedicated lighting distribution boards to facilitate future energy monitoring work.

5.2 Air Conditioning Installations

The Code requires that all air conditioning units and plants drawing electrical power from the power distribution system should preferably comply with the latest edition of the Code of Practice for Energy Efficiency of Air Conditioning Installations. Any motor control centre (MCC) or motor for air conditioning installations, having an output power of 5kW or greater, with or without variable speed drives, should also be equipped, if necessary, with appropriate power factor correction or harmonic filtering devices to improve the power factor to a minimum of 0.85 and restrict the total harmonic distortion (THD) of current to the value as shown in Table 6.1.

The main purpose of this requirement is to correct power factor and/or reduce harmonic distortion as much as possible at the pollution sources rather than at the main LV switchboard so as to minimise the unnecessary power losses in the distribution cables.

Dedicate feeder circuits should be provided for individual AC plant to facilitate separate metering and monitoring of the energy consumption for future energy management and auditing purposes.

The booklet "Guidelines on Energy Efficiency of Air Conditioning Installations" published by EMSD is also available for designers to obtain more information and guidance on energy efficient air-conditioning design, operation and maintenance.

5.3 Vertical Transportation

The Code requires that all electrically driven equipment and motors forming part of a vertical transportation system shall preferably comply with the Code of Practice for Energy Efficiency of Lift and Escalator Installations. Modern lift driving systems (e.g. ACVV, VVVF etc.) should be designed and manufactured not simply to be efficient on its own but with due concern on the impact of probable pollution on the building's power supply system.

Dedicate feeders should be provided for lifts and escalators circuits to facilitate separate metering and monitoring of the energy consumption for future energy management and auditing purposes.

5.4 Motors and Drives

5.4.1 Motor Efficiency

The electric motor is probably the most widely used piece of electrical equipment in building services installations, the 3-phase induction motor in particular. It can operate at different speeds depending on the number of poles and offers a relatively cheap and versatile source of rotating mechanical power. Except for motors which are components of packaged equipment, any polyphase induction motor that is expected to operate more than 1,000 hours per year should use “energy-efficient” motors tested to relevant international standards such as IEEE 112. The nominal full-load motor efficiency shall be no less than those shown in Table 5.1.

TABLE 5.1: Minimum Acceptable Nominal Full-Load Motor Efficiency for Single-Speed Polyphase Motors

Motor Rated Output (P) (kW)	Minimum Rated Efficiency (%)
$1.1 \leq P < 1.5$	76.2
$1.5 \leq P < 2.2$	78.5
$2.2 \leq P < 3$	81
$3 \leq P < 4$	82.6
$4 \leq P < 5.5$	84.2
$5.5 \leq P < 7.5$	85.7
$7.5 \leq P < 11$	87
$11 \leq P < 15$	88.4
$15 \leq P < 18.5$	89.4
$18.5 \leq P < 22$	90
$22 \leq P < 30$	90.5
$30 \leq P < 37$	91.4
$37 \leq P < 45$	92
$45 \leq P < 55$	92.5
$55 \leq P < 75$	93
$75 \leq P < 90$	93.6
$P \geq 90$	93.9

The above figures are based on CEMEP eff2, i.e. efficiency class 2 under the European Committee of Manufacturers of Electrical Machines and Power Electronics, an organization representing motor manufacturers in the European Union. The CEMEP provides classification of motors according to their efficiencies.

Losses in induction motors consist of those that vary with the load and those that are constant whatever the load. The split is about 70% and 30% respectively of full load losses. The electrical energy, which is not converted to motion, is dissipated as heat in motors.

The electrical load losses include the motor resistance loss, the stator resistance loss and stray losses. When the motor is running with no load these copper losses are very small. However, once a load is applied, these losses will increase as the square of the motor current (i.e. I^2R losses). In addition there are iron losses in the magnetising circuit of the motor. These losses, known as eddy current and hysteresis losses, are related to voltage and are, therefore, constant,

irrespective of motor load. The mechanical losses are the friction in bearings, the turbulence around the rotor as it rotates and the windage of the cooling fan. Motors designed to minimise all these losses are termed 'high efficiency motors'.

The other factor that may be taken into account in the design, is consideration of 'normal' loading. If it can be shown that the application of a motor, while requiring full power, at most of the time runs at say 60% full load, the motor could be designed so that its highest efficiency is at this load, rather than at full load output.

Design to minimise electrical losses will mean increased cost in terms of more materials. As I^2R losses are reduced, the cooling fan can also be reduced (so reducing windage loss). At present the cost for a high efficiency motor is higher than for a standard motor, but this may change as the price differential between the two motor types decreases in the near future. Typical high efficiency motor and standard motor efficiency curves are shown in Fig. 5.1.

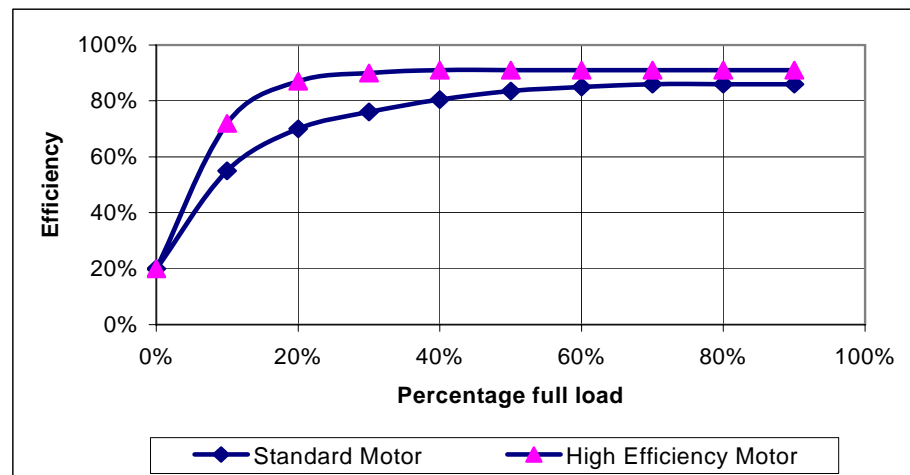

Fig. 5.1: High efficiency & standard motor efficiency against motor load

5.4.2 Motor Sizing

The Code requires that every motor having an output power of 5kW or greater should be sized by not more than 125% of the anticipated system load unless the load characteristic requires specially high starting torque or frequent starting. If a standard rated motor is not available within the desired size range, the next larger standard size may be used.

The maximum load for which motors are installed may be considerably less than the motor rating. There are a number of reasons for this, some of which originate in the plant itself, for example, allowances in the mechanical design for unexpected contingencies. Other than this, it is common practice to oversize the electric motors in an endeavour to ensure reliability and allow for possible changes in plant operation.

Motor oversizing differs from application to application. A typical example indicates that average loading of motors is probably in the order of 65%. In many cases the end user has not been able to choose the electric motor, it comes as a package with the equipment and, as the equipment supplier must assume the worst case condition for sizing the motor. It is possible for the motor to be sized more in line with its actual maximum or anticipated load. In

many building applications, such as fans and pumps, the motors are considerably oversized.

Efficiencies of motors vary with size/rating, loading and manufacturers. Typical standard motors may have efficiencies at full load between 55% and 95% depending on size and speed. As shown in Fig. 5.1, the efficiency curves of standard motors is reasonably constant down to 75% full load and fall rapidly when operate below 50% full load.

It follows that, provided motors are running at a reasonably constant load, oversizing by up to 25% will not seriously affect efficiency. However, if the load is fluctuating and unlikely to achieve 75% full load, the efficiency can be adversely affected.

Displacement power factor is also seriously affected by light loading of motor. In fact, power factor falls off more rapidly than efficiency does and consequently, if motors are lightly loaded and/or oversized, the power factor correction in term of kVAr needs to be greater, involving higher cost.

Unnecessary motor oversizing would therefore:

- increase the initial cost of the motor itself;
- increase the capital cost of the associate switchgear, starting devices and wiring;
- require higher capital cost for power factor correction equipment; and
- increase losses and consume more electrical energy due to lower efficiencies.

5.4.3 Variable Speed Drive (VSD)

A variable speed drive (VSD) should be employed for motor in a variable flow application. Any motor control centre (MCC) with VSDs should also be equipped, if necessary, with appropriate power factor correction or harmonic reduction devices to improve the power factor to a minimum of 0.85 and restrict the THD current to the value as shown in Table 6.1.

In case of motor circuits using VSDs, group compensation at the sub-main panel or MCC is allowed, provided that the maximum allowable fifth harmonic current distortion at the VSD input terminals during operation within the variable speed range is less than 35%.

The use of variable speed drives (VSD) in place of less efficient throttling, bypassing or similar mechanical devices should be employed for variable flow systems. This applies to both air circulation and water pumping systems.

The utilisation of VSD for 3-phase induction motor will provide more flexible and predictable loads with higher power factor, smaller starting-current inrush, and more load management opportunities. Problems might also arise from the harmonics, which generate from some types of VSDs. Such harmonics can disrupt other type of equipment and can also increase losses in the power distribution system.

Most of the 3-phase induction motors are fitted to fans or pumps in buildings. The flow from most fans and pumps is controlled by restricting the flow by mechanical means; dampers are used on fans, and valves are used on pumps. This mechanical constriction will control the flow and may reduce the load on

the fan or pump motor, but the constriction itself adds an energy loss, which is obviously inefficient. Hence if the flow can be controlled by reducing the speed of the fan or pump motor, this will offer a more efficient means of achieving flow control.

In fact the saving is greater than that might initially be expected. As the speed of the fan or pump is reduced, the flow will reduce proportionally, while the power required by the fan or the pump will reduce with the cube of the speed. For example, if the flow can be reduced by 20%, the corresponding speed reduction will be 80% of normal speed, the power required is 0.8^3 and is equal to 51.2%. This level of potential energy saving makes the use of Variable Speed Drive (VSD) to control flow one of the most important, cost-effective investments in energy efficiency for motors.

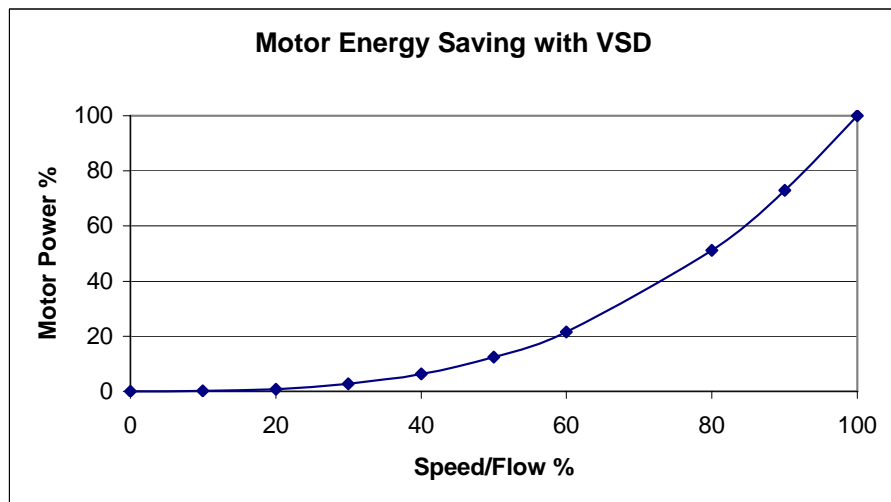

Fig.5.2: Percentage Motor Power Consumption as a Function of Variable Volume Flow

It has always been possible to control the speed of ac motors, but in the past this was only justified for exceptional cases due to the high cost and complexity of the system. In recent years, modern development in power semiconductors and microprocessors have allowed the introduction of electronic VSDs which have improved performance and reliability over earlier systems while reducing the equipment cost. Hence a range of motors in building services can now be considered for retrofitting with VSD based on the economics of energy saving.

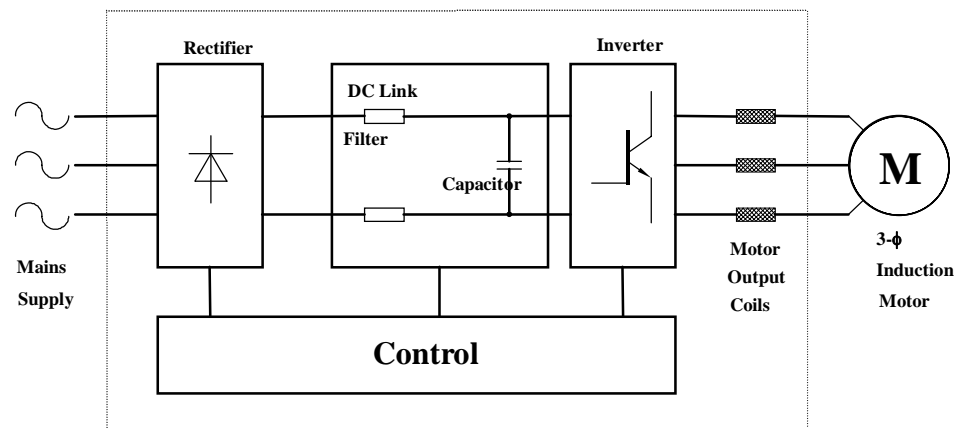

Fig.5.3: Basic Configuration of a typical Variable Speed Drive (VSD) System

A VSD can be regarded as a frequency converter rectifying ac voltages from the mains supply into dc, and then modifies this into a ac voltage with variable amplitude and frequency. The motor is thus supplied with variable voltage and frequency, which enables infinitely variable speed regulation of three-phase, asynchronous standard induction motors.

It is important to establish the operating conditions for a particular motor before selecting which VSD to be used. The detail of the motor rating, operating hours, flow requirements and electricity costs will determine which type of VSD can be considered.

VSDs have been successfully used in a range of applications. Examples include motors on primary air-handling units, variable air volume air-handling units, secondary chilled water pumps, etc.

5.4.4 Power Transfer Device

Power transfer devices used for motors having an output power of 5kW or greater, and to change continually the rotational speed, torque, and direction, should be avoided as far as practical, and directly connected motors running at the appropriate speed via variable speed drives should be used. If the use of belts is unavoidable, synchronous belts - which have teeth that fit into grooves on a driven sprocket, preventing slip losses - should preferably be employed to provide a higher efficiency over friction belts.

As discussed in section 5.4.3 for the application of VSDs and other modern sophisticated motor drive equipment should be used in lieu of the conventional mechanical power transfer devices. Energy losses via power transmission could then be minimised.

5.5 Power Factor Improvement

The Code requires that the total power factor for any circuit should not be less than 0.85. Design calculations are required to demonstrate adequate provision of power factor correction equipment to achieve the minimum circuit power factor of 0.85. If the quantity and nature of inductive loads and/or non-linear loads to be installed in the building cannot be assessed initially, appropriate power factor correction devices shall be provided at a later date after occupation.

The power factor of a circuit can simply be defined as the ratio of active power (P) to the apparent power (S) of the circuit. For linear circuit, power factor also equals to the cosine function of the angle shift between the a.c. supply voltage and current. Capacitors can normally be used to improve power factor of this circuit type. In case of non-linear circuit with distorted current waveform, the situation is more complicated and capacitors alone can no longer be capable to improve power factor. We need to introduce the terms 'Total Power Factor' and 'Displacement Power Factor' to explain the method used for improving power factor of non-linear circuits.

Consider a non-linear circuit with load current I , which is the rms value of the fundamental (I_1) and all harmonic components (I_2, I_3, I_4, \dots), an expression of the power factor could be found as follows, assuming the circuit is fed from a line voltage having a low value of distortion and only the fundamental sinusoidal value U_1 is significant:

Apparent Power: $S = UI$

$$\begin{aligned} S^2 &= (UI)^2 = U_1^2 (I_1^2 + I_2^2 + I_3^2 + I_4^2 + \dots) \\ &= U_1^2 I_1^2 \cos^2 \theta + U_1^2 I_1^2 \sin^2 \theta + U_1^2 (I_2^2 + I_3^2 + I_4^2 + \dots) \end{aligned}$$

According to this expression in the distorted circuit, the apparent power contained three major components:

1. Active Power in kW $P = U_1 I_1 \cos\theta$ (This is the effective useful power)
2. Reactive Power in kVAr $Q_1 = U_1 I_1 \sin\theta$
(This is the fluctuating power due to the fundamental component and coincides with the conventional concept of reactive power in an inductive circuit consumed and returned to the network during the creation of magnetic fields)
3. Distortion Power in kVAd $D^2 = U_1^2 \cdot (I_2^2 + I_3^2 + I_4^2 + \dots)$
(This power appears only in distorted circuits and its physical meaning is that of a fluctuating power due to the presence of harmonic currents)

The relationship among these three power components could further be shown in the following power triangles:

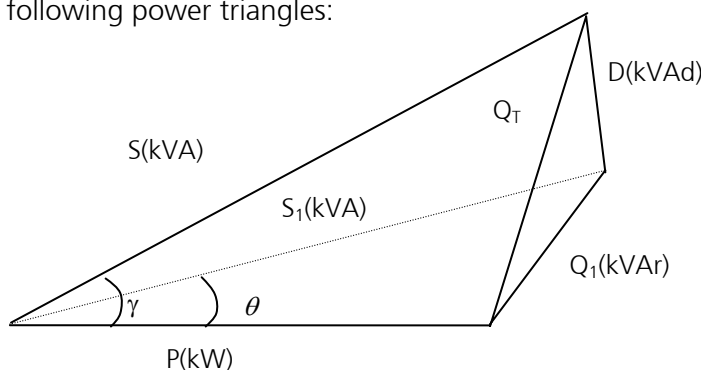

Fig. 5.4 : Power Triangles

1. Fundamental Components: $S_1^2 = P^2 + Q_1^2$
(Note : Displacement Power Factor $\cos\theta = P/S_1$)
2. Fluctuating Power: $Q_T^2 = Q_1^2 + D^2$
3. Power Triangle in Distorted Circuit: $S^2 = Q_T^2 + P^2$
(Note : Total Power Factor, $\cos\gamma = P/S$, is always smaller than the Displacement Power Factor, $\cos\theta$, and could be improved by either reducing the amount of harmonic distortion power (kVAd) or reactive power (kVAr))

From definition:
$$I = \sqrt{\sum_{h=1}^{\infty} I_h^2} = \sqrt{I_1^2 + I_2^2 + I_3^2 + \dots}$$

and
$$\text{THD} = \frac{\sqrt{\sum_{h=2}^{\infty} (I_h)^2}}{I_1}$$

Therefore,
$$I_b = I_1 \sqrt{1 + \text{THD}^2}$$

and Total Power Factor =
$$\frac{P}{S} = \frac{U I_1 \cos\theta}{U I_1 \sqrt{1 + \text{THD}^2}} = \frac{\cos\theta}{\sqrt{1 + \text{THD}^2}}$$

The expression only gives an approximate formula without any voltage distortion caused by voltage drop in line impedance. These harmonic voltages will also give active and reactive components of power but the active power is generally wasted as heat dissipation in conductors and loads themselves.

The power factor is also a measure of system losses. It is an indication of how much of the system generating capacity is utilised by consumers. A low power factor means, for the same generating capacity, less power is made available to the consumers as the result of distribution losses and is, therefore, most undesirable. Supply companies in Hong Kong do not permit their customers to have the power factor fall below 0.85 at any time. Power factor correction capacitors can be installed anywhere in the power distribution system. Bank compensation is more convenient for design and installation and may cost less, but is meant to avoid utility penalty or to fulfil power companies' bulk tariff conditions rather than to capture both external & internal benefits for system optimisation. For the consumer, the point is not to provide a power factor acceptable to the utility, but to maximise net economic savings, and that may well mean going not just to but beyond power companies' minimum requirements. Local compensation by putting the power factor correction capacitor on the inductive/motor load serves the purpose, and is flexible and right to the point.

In a circuit with non-linear loads, harmonic currents are induced and add to the fundamental current. The apparent power needed to obtain the same active power is significantly greater than in the case of pure sinusoidal consumption and thus the power factor is worsened. As a result of greater total rms current in a circuit having harmonics as is strictly necessary to carry the active power, a bigger copper loss, which is proportional to the square of the current, occurs in the circuit.

Power factor correction using the conventional capacitor bank must be carefully designed to avoid overcurrent and resonance in the supply networks with high contents of harmonics. For circuit with high displacement power factor, the relationship between total power factor and THD can be shown in Fig. 5.5. Power factor for this type of non-linear circuit can only be corrected by appropriate harmonic filters. Details on harmonic current filtering could also be found in section 6.1.

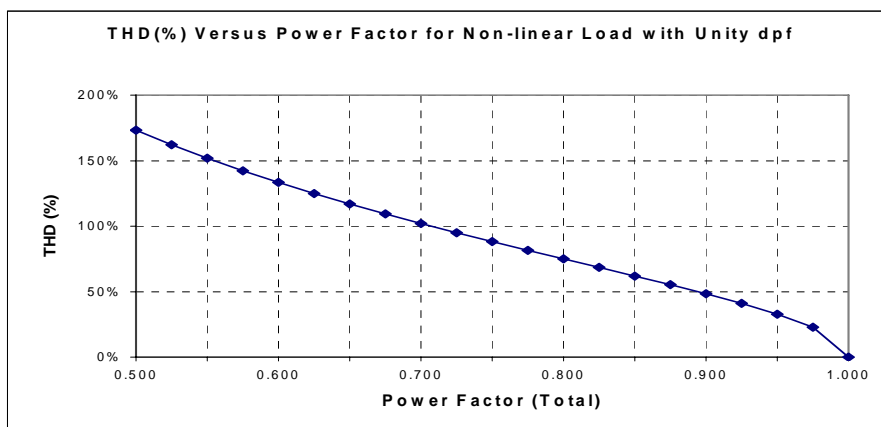

Fig. 5.5 : Relationship between THD and Power Factor

5.6 Other Good Practice

5.6.1 Office Equipment

As one of the major international financial and commercial centres of the world, Hong Kong is consuming a significant amount of electrical energy through its

use office equipment in commercial buildings. According to a recent survey on design parameters for electrical installations in Hong Kong, the demand provision for tenants' small power was between 50 VA/m² to 100 VA/m². The total energy consumed by office equipment, together with the space cooling requirement to offset the waste heat generated by office equipment, account for a very large proportion of the total building energy used, if no any power management control is made to the operation of office equipment. Of the total energy used by office equipment, approximately 50% is for personal computers (PC) & monitors and 25% for printers, with the remaining 25% for copiers, facsimile machines, and other miscellaneous equipment. Consumers should therefore select office equipment complete with 'power management' or 'energy saving' feature that power down unnecessary components within the equipment while maintaining essential function or memory when the equipment is being idled or after a user-specified inactivity period.

5.6.2 Electrical Appliances

Consumers should be encouraged to select and purchase energy efficient electrical appliances such as refrigerators, room coolers, washing machines, etc. which are registered under EMSD's The Hong Kong Voluntary Energy Efficiency Labelling Scheme (EELS) (<http://www.emsd.gov.hk/emsd/eng/pee>) with good energy efficiency, i.e. grade 3 or better.

The energy labels under the EELS for Household Appliances provide more energy consumption data to consumers. There are two types of labels, the grading type and the recognition type. The energy labels will only be displayed on appliances that have been registered under the scheme. For grading type, the grades are from 1 to 5, grade 1 being the most energy efficient. Examples are a grade 1 room cooler being at least 15% more energy efficient than an average (grade 3) product and a grade 1 refrigerator being at least 35% more energy efficient than average. For recognition type, the label would only be granted to appliances meeting certain specific energy performance standards, examples being the labels for compact fluorescent lamp and electronic ballast.

5.6.3 Demand Side Management (DSM)

The Demand Side Management (DSM) programmes developed by the utility companies have tried to change consumers' electricity usage behaviour to achieve a more efficient use of electric energy and a more desirable building load factor, which is beneficial to both consumers and the utility companies. Designers are encouraged to incorporate into their design all latest DSM programmes available in order to reduce the building maximum demand and the electrical energy consumption. DSM Energy Efficiency Programmes include utilities' special ice-storage air-conditioning tariff and time-of-use tariff, rebates offered to participants to purchase energy efficient electrical appliances/installations (e.g. refrigerators, air-conditioners, variable speed drives, compact fluorescent lamps, electronic ballasts) etc.

Load factor is defined as the ratio of the average load of a building in kW, consumed during a designated period, to the peak or maximum load in kW, occurring in that same period. A system load factor measures the degree of utilisation of the power supply system. By increasing the system load factor, the need to provide larger building transformer capacity may be avoided and the construction of new generating and transmission plant may be delayed or the magnitude of the increase reduced.

6. ENERGY EFFICIENCY REQUIREMENT FOR POWER QUALITY

6.1 Maximum Total Harmonic Distortion (THD) of Current on LV Circuits

The total harmonic distortion (THD) of current for any circuit should not exceed the appropriate figures in Table 6.1. According to the quantity and nature of the known non-linear equipment to be installed in the building, design calculations are required to demonstrate sufficient provision of appropriate harmonic reduction devices to restrict harmonic currents of the non-linear loads at the harmonic sources, such that the maximum THD of circuit currents, at rated load conditions, shall be limited to those figures as shown in Table 6.1 below. However, for lift & escalator installations complying with the Code of Practice for Energy Efficiency of Lift and Escalator Installations, the THD requirements of Table 6.1 can be relaxed.

TABLE 6.1: Maximum THD of Current in Percentage of Fundamental

Circuit Current at Rated Load Condition 'I' at 380V/220V	Maximum Total Harmonic Distortion (THD) of Current
$I < 40A$	20.0%
$40A \leq I < 400A$	15.0%
$400A \leq I < 800A$	12.0%
$800A \leq I < 2000A$	8.0%
$I \geq 2000A$	5.0%

In case of motor circuits using VSDs, group compensation at the sub-main panel or MCC is allowed, provided that the maximum allowable fifth harmonic current distortion at the VSD input terminals during operation within the variable speed range is less than 35%.

If the quantity and nature of non-linear equipment to be installed in the building cannot be assessed initially, appropriate harmonic reduction devices shall be provided at a later date after occupation.

Table 6.1 is based on IEEE 519 and is the practices and requirements recommended by the utility companies.

Small levels of harmonic distortion are always present in the supply system and have been tolerated for years. The problem has been aggravated in the recent years with the proliferation of various kinds of non-linear loads used in buildings such as computer equipment, VSDs, ACVV / VVVF lift drive systems, electronic ballasts, UPS systems, copying machines, telecommunication equipment, etc.

The problems associated with the presence of harmonics on the power distribution system are not just the power quality problems but also affect the energy efficiency of the system. Typical problems include overheating distribution transformers, overloading neutral conductors, overheating rotating machinery, unacceptable neutral-to-earth voltage, distorted supply voltage waveform, communication interference (EMI), capacitor banks failure, incorrect tripping of fuses and circuit breakers, malfunctioning of electronic/computing equipment, and most importance of all, inefficient distribution of electrical power.

The Supply Rules published by both CLP and HEC have also included clauses and limitation of harmonic current distortion on customer's interference with quality of supply. They reserve the right to restrict to disconnect the supply to any installation

which by reason of unsteady or fluctuating demand or by injection of undesirable waveform on the company's system, adversely affects the company's system and/or the electricity supply to other customers.

Electronic equipment nowadays tends to be distributed in the building on various final circuits and socket outlets rather than centralised in one area as in a computer room where special power provisions (e.g. UPS system) are made. Most of the losses associated with harmonics are in the building wiring circuits. Harmonic distortion is serious at the terminals of the non-linear loads, but tends to be diluted when combined with linear loads at points upstream in the system.

The total harmonic distortion (THD) is defined by

$$\text{THD} = \frac{\sqrt{\sum_{h=2}^{\infty} (I_h)^2}}{I_1}$$

where I_h is the rms current of the h^{th} harmonic current, and I_1 is the rms value of the fundamental current. A typical supply voltage waveform at a consumer's metering point (or point of common coupling) normally doesn't exceed 5% THD in Hong Kong but for some high-rise commercial buildings, the voltage THD exceeding 10% is not uncommon especially at those higher level floors fed with a common rising mains. The third harmonic is normally the most prominent component (zero sequence), resulting in high neutral current flow in the neutral conductors of a power distribution system. The adverse effects of high neutral current will be additional energy losses, overcurrent and additional voltage drop causing undesirable high neutral to earth voltage and low phase to neutral voltage.

For electronic appliances that are retrofitted to comply with the Building Energy Codes for energy saving purpose, such as electronic ballasts, VSDs, VVVF lift drive system etc., an important point needs to be considered is the **energy saving must not be surmounted by added harmonic losses** in the power distribution system.

In cable distribution system, the only power loss component is I^2R , where I could be increased by the harmonic distortion, and the R value is determined by its dc value plus ac skin and proximity effects. The rms value including harmonic currents is defined by:

$$I = \sqrt{\sum_{h=1}^{\infty} I_h^2} = \sqrt{I_1^2 + I_2^2 + I_3^2 + \dots}$$

The total rms current would be:

$$I = I_1 \sqrt{1 + \text{THD}^2}$$

This equation indicates that, without harmonics, the total rms current is simply the value of the fundamental component. For a PC with 130% THD, the total current is nearly 64% higher than the fundamental current.

Taking into account the frequency-related effects, a ratio of ac to dc resistance, k_c can be defined as

$$k_c = \frac{R_{ac}}{R_{dc}} = 1 + y_s + y_p$$

Where y_s is the resistance gain due to skin effect, and y_p is the resistance gain due to proximity effect.

The resistance gain due to skin and proximity effects for multicore cables, as a function of frequency, conductor diameter and spacing of cores, can be assessed from the formula and information given in IEC287-1-1 "Current rating equations and calculation of losses".

Consider three different sized cables: 10mm², 150mm² and 400mm² 4-core PVC/SWA/PVC cables, typically used in a building power distribution system. Their ac/dc resistance ratios at different frequencies can be calculated according to BS IEC 60287-1-1 and are shown in Fig. 6.1 below. It is noted that for small cables, skin and proximity effects are small at 3rd and 5th harmonic frequencies which are normally the dominating ones in the power distribution system of a building.

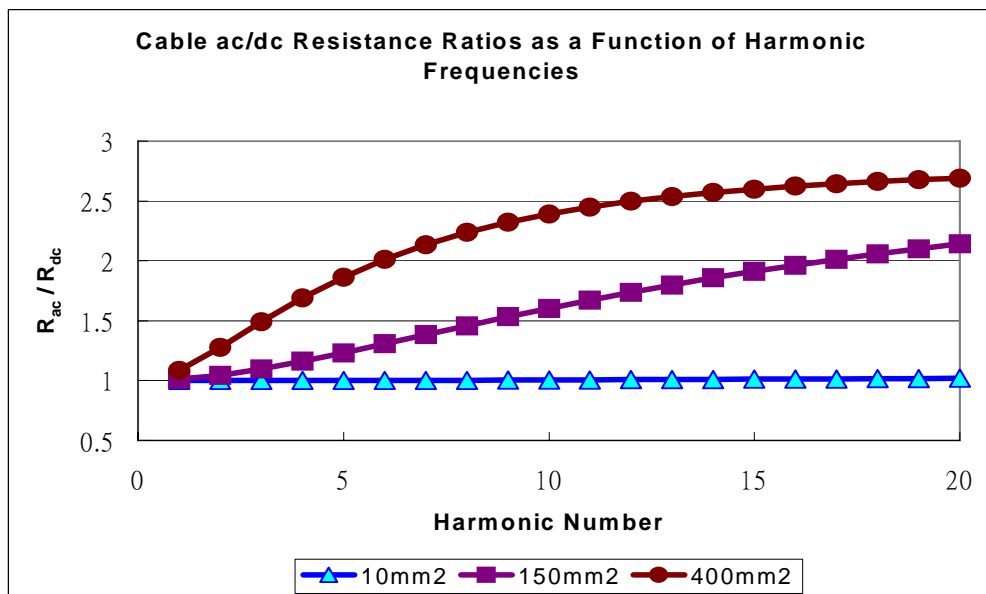

Fig. 6.1 : Variation of a.c. Resistance with Harmonic Number in 4/C PVC/SWA/PVC Cables

Most of the distribution transformers in Hong Kong are provided by the two power supply companies and all these transformer losses are therefore absorbed by the power companies. Harmonics produce extra losses in transformers and these costs could not be recovered from their consumers. Both CLP and HEC have been considering to specify requirements that the consumers must comply with in order to limit the magnitudes of harmonic distortion at the consumer's metering point.

Transformer loss components include no-load (P_{NL}) and load-related loss (P_{LL}). The load loss, as a function of load current, can be divided into I^2R (P_R) loss and stray losses. The stray losses are caused by eddy-currents that produce stray electromagnetic flux in the windings, core, core clamps, magnetic shield and other parts of the transformer. For harmonic-rich currents, the eddy-current loss (P_{EC}) in the windings is the most dominant loss component.

$$P_{Loss} = P_{NL} + P_R + P_{EC}$$

For non-linear load currents, the total rms current can be obtained by the equations above, and the power loss can be obtained by the sum of the squares of the fundamental and harmonic currents as follow:

$$P_R = \sum_{h=1}^{\infty} I_h^2 R_h$$

The winding eddy current loss in transformers increases proportional to the square of the product of harmonic current and its corresponding frequency. Given the winding eddy current loss at the fundamental frequency as P_{EC1} , the approximate total eddy current losses including harmonic frequency components can be calculated by

$$P_{EC} = P_{EC1} \sum_{h=1}^{\infty} I_h^2 h^2$$

Other equipment that may be affected by harmonics include protective devices, computers, motors, capacitors, reactors, relays, metering instrument, emergency generators, etc. The major harmonic effects to these equipment include performance degradation, increased losses and heating, reduced life, and possible resonance. For motor and relays, the primary loss mechanism is the negative sequence harmonic voltage (e.g. 5th and 11th order) that is present at the terminals of the equipment.

At the design stage of a building project, any landlord's non-linear loads (e.g. computers, UPS systems, discharge lamps, VSDs, ACVV/VVF lift drive systems etc.) shall be identified, and the level of harmonic, including the potential tenants' non-linear equipment, preliminarily assessed. This assessment is of paramount importance when selecting and sizing the appropriate harmonic filters and the power factor correction capacitors. Unacceptable harmonic distortion may cause overcurrent or resonance between the capacitor and the supply system.

The cost of harmonic-related losses depends on the loading condition, time of operation, and the conductor length. Harmonic elimination or reactive compensation at the source of harmonic generation, before any additional current flows in the power system, will always be the most complete and effective approach. However, this will lead to many small rather than a few large filtering devices. The expected economy of a large-scale harmonic filter suggests that the best location is where several distorted currents are combined, such as the motor control centre (MCC) feeding several VSDs. Compensation of harmonics near the service entrance, or metering point, has very little value for reduction of harmonic-related losses.

With incentives like IEC Standard 1000-3-2, which require some mitigation of harmonics at equipment terminals, many electronic equipment manufacturers are now looking for cost-effective ways to reduce harmonics inside their products. Recent tests on some electronic ballasts in Hong Kong revealed that THD current could be lower than 5% with built-in harmonic filters as compared with the previous products with THD above 40%. Similar harmonic filtering devices could also be incorporated into the design of PC power supply to limit harmonics for compliance with the IEC standard. As far as the large non-linear loads are concerned, such as VSD with 6-pulse Pulse Width Modulation (PWM) and VVF lift drive system, reduction of harmonics could be achieved by the installation of individual dc-link inductor, ac-side inductor, passive or active filter, etc.

With the proliferation of non-linear loads nowadays, harmonic-related losses in building wiring systems will be worsened. These losses may cause significant safety problems, overheating conductors, increasing power bill, and tying up capacity of the

power system. Reducing harmonics will save energy and release additional capacity to serve other loads.

Compliance with the harmonic requirements of the Electrical Energy Code could be achieved by applying harmonic filtering devices (passive filters or active filters) at appropriate location. The great potential for loss reduction and released power system capacity is near the harmonic generating loads, while compensation near the service entrance is of little value. For designing the power system of a new commercial building, future harmonic problems need to be considered and a certain percentage of harmonic distortion must be allowed for and incorporated into the design. The general practice of installing capacitor banks at the main LV switchboards for main power factor correction should be re-considered. Ordinary capacitor banks can no longer be used to correct low total power factor caused by harmonics. The capacitor would act as a harmonic sink and could be damaged by high frequency harmonic or resonance currents passing through it.

Active filters, tuned or broadband passive filters are required to solve existing and future harmonic problems for compliance with the requirements specified by the government and the power companies. Application data on these filters, for use in both harmonic reduction and reactive compensation, is not adequately available in the market or in standards. Further investigation comparing the effectiveness and cost of various harmonic mitigation technology requires further elaboration among the government, electrical consultants, manufacturers and the power companies.

Should any harmonic filter be used to reduce the harmonic content, the designer should **pay attention to the energy consumption of the filter itself**.

6.2 Balancing of Single-phase Loads

All single-phase loads, especially those with non-linear characteristics, in an electrical installation with a three-phase supply should be evenly and reasonably distributed among the phases. Such provisions are required to be demonstrated in the design for all three-phase 4-wire circuits exceeding 100A with single-phase loads.

The maximum unbalanced single-phase loads distribution, in term of percentage current unbalance shall not exceed 10%. The percentage current unbalance can be determined by the following expression:

$$I_u = (I_d \times 100) / I_a$$

Where I_u = percentage current unbalance

I_d = maximum current deviation from the average current

I_a = average current among three phases

The connection of single-phase loads of different characteristics and power consumption to the three-phase power supply system will result in unequal currents flowing in the three-phase power circuits and unbalanced phase voltages at the power supply point, i.e. unbalanced distortion.

The adverse effects of unbalanced distortion on the power distribution system include:

- a) additional power losses and voltage drop in the neutral conductors,
- b) causing unbalanced 3-phase voltages in the power distribution system,
- c) reduced forward operating torque and overheating of induction motors,
- d) excessive electromagnetic interference (EMI) to sensitive equipment in buildings, &
- e) additional error in power system measurement.

All single-phase loads are potential sources of unbalanced distortion. They should be carefully planned at design stage for balancing, even though the random connection and operation of large number of small rating single-phase loads on the final circuits will tend to cancel their unbalance distortion effect in the main and sub-main circuits.

A 10% unbalanced phase current in a 3-phase 4-wire power distribution system with an average phase current of 100A (Fig. 6.2) would produce a neutral current of about 17A and increase the total copper loss by about 1%. The combination effect of 10% unbalanced and 30% THD phase currents (Fig. 6.3) on the same circuit would produce a neutral current almost the same magnitude as the phase current resulting in much higher losses in a 3-phase 4-wire power distribution system.

For residential buildings, the final circuit configuration may not be in a multiple of 3. Balancing on the riser could be achieved by “rotating” the RYB phases floor-by-floor continuously.

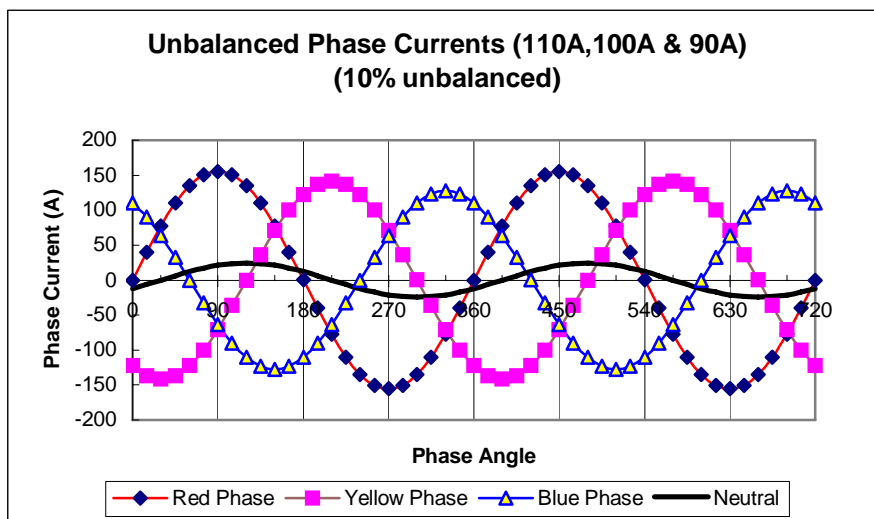

Fig. 6.2 : Neutral Current with 10% Unbalance among Phase Currents

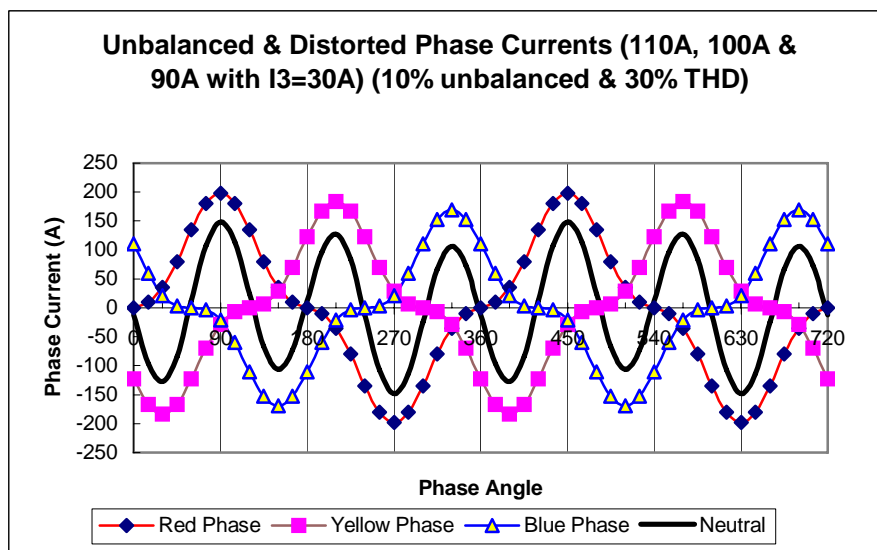

Fig. 6.3 : Neutral Current with 10% Unbalance & 30% THD

Voltage level variation and unbalanced voltage caused by unbalanced distortion of single-phase loads are some of the voltage deviations which can affect motor operating cost and reliability. The published 3-phase induction motor characteristics are based on perfect balanced voltages between phases. Overheating (additional loss) and reduction in output torque are serious ill effects caused by operation of induction motors on unbalanced voltages. The magnitude of these ill effects is directly related to the degree of voltage unbalance.

The adverse effects of unbalanced voltage on 3-phase induction motor operation comes from the fact that the unbalanced voltage breaks down into the positive sequence component and the opposing negative sequence component.

The positive sequence component produces the wanted positive torque. This torque is generally of less magnitude than the normal torque output from a balanced voltage supply and with somewhat higher than normal motor losses, because the positive sequence voltage is usually lower than rated voltage. The negative sequence component produces a negative torque, which is not required. All the motor power that produces this torque goes directly into the loss that must be absorbed by the motor. By increasing the amount of unbalanced voltage, the positive sequence voltage decreases and the negative sequence voltage increases. Both of these changes are detrimental to the successful operation of motor. Positive (E_{+ve}) and negative (E_{-ve}) sequence voltages can be calculated by the symmetrical components relationship as

$$E_{+ve} = \frac{1}{3}(E_R + aE_Y + a^2E_B)$$

$$E_{-ve} = \frac{1}{3}(E_R + a^2E_Y + aE_B)$$

where E_R , E_Y and E_B are the original unbalanced voltages for red, yellow and blue phases and $a = -1/2 + j\sqrt{3}/2$.

The application of negative sequence voltage to the terminal of a 3-phase machine produces a flux, which rotates in the opposite direction to that produced by positive sequence voltage. Thus, at synchronous speed, voltages and currents are induced in the rotor at twice the line frequency. The application of negative sequence voltage can therefore affect torque, stator and rotor copper losses, rotor iron losses and consequently machine overheating. It is interesting to note that harmonic voltages of the 5th, 11th, 17th, etc. order are also negative sequence and would produce similar adverse effect as unbalanced voltages.

7. REQUIREMENTS FOR METERING AND MONITORING FACILITIES

7.1 Main Circuits

The Code requires that all main incoming circuits exceeding 400A (3-phase 380V) current rating should be incorporated with metering devices, or provisions for the ready connection of such devices, for measuring voltages (all phase-to-phase and phase-to-neutral), currents (all lines and neutral currents) and power factor, and for recording total energy consumption (kWh) and maximum demand (kVA).

7.2 Sub-main and Feeder Circuits

The Code requires that all sub-main distribution and individual feeder circuits exceeding 200A (3-phase 380V) current rating should be complete with metering devices, or provisions for the ready connection of such devices, to measure currents (3 phases and neutral) and record energy consumption in kWh for energy monitoring and audit purposes. This requirement does not apply to circuits used for compensation of reactive and distortion power.

The advanced power-monitoring instrument available nowadays can be used for metering, power quality analysis, energy management and supervisory control for power distribution systems. In these digital meters, true waveforms of all voltages and currents are sampled and computations are carried out by built-in microprocessors to take into account of all the distortions associated with both currents and voltages. In this case, the true total power factor, true active power and voltages and currents in true rms values can be obtained. The instrument can also be linked into the building management system of the building as one element in an energy management network. Selection for applying the most beneficial tariff system could also be analysed by the instrument from the logged data of energy consumption and load profile of the building.

8. ENERGY EFFICIENCY IN OPERATION AND MAINTENANCE OF ELECTRICAL INSTALLATIONS IN BUILDINGS

8.1 Emergency Maintenance

The emergency maintenance can hardly be regarded as maintenance in the sense that, in many cases, it consists of an urgent repair to, or replacement of, electrical equipment that has ceased to function effectively. Obviously, it is better to follow a rigorous 'Planned Maintenance Programme' for all essential electrical power distribution installations and equipment in buildings to reduce the frequency of emergency maintenance tasks.

8.2 Planned Maintenance

In the use of electrical plant and equipment there are obviously sources of danger recognised in the Electricity (Wiring) Regulations. These regulations are mandatory and serve to ensure that all electrical plants and equipment are adequately maintained and tested to prevent any dangerous situation arising that could harm the users of such equipment or the building occupants. Normally, maintenance carried out solely for safety reasons will be covered by standard procedures, which in some instances will have to fulfil the relevant Code of Practice for the Electricity (Wiring) Regulations. For example, Code 20 'Periodic Inspection, Testing and Certification', Code 21 'Procedures for Inspection, Testing and Certification' and Code 22 'Making and Keeping of Records'. As these types of maintenance work are solely legislative requirements it is not proposed to discuss here on economic considerations.

Planned maintenance can be carried out on the basis of the operation of the piece of electrical equipment itself. For example, it is worth considering whether all electric motors should be periodically cleaned and inspected, making sure that dirt and dust has not interfered with the self cooling of the motor and that there is no oil leakage into the motor's windings. Bearing should also be checked for wear and tear to prevent contact between the rotor and stator. Maintenance can also be based on the complete item of plant, or auxiliary plant, such as the central air conditioning plant of a tall building.

8.3 Purpose of Maintenance

Apart from safety, maintenance is needed to keep plant in an acceptable condition. Maintenance of this kind must be reviewed on an economic and energy efficiency basis. While it is appreciated that breakdown of plant may result in costly interruption of normal building operation, it must also be borne in mind that stopping plant for maintenance can also cause a loss in production. Equipment on continuous and arduous duty, e.g. switchboards, motor control centres, air-handling units, chiller plant etc., require more attention than that which is lightly loaded and rarely used.

8.4 Economic and Energy Efficiency of Maintenance

Apart from the above considerations there will be the question of whether to repair or replace faulty equipment. This requires analysis of the past and future maintenance costs and the benefits of new equipment. There has been much operational research carried out into such things as the probability of breakdown, replacement and repair limits, and overhaul policies. This obviously requires considerable effort and expertise and may need the services of a specialist consultant. However, some simple initial steps can be taken as far as the economic and energy efficiency is concerned for maintenance of electrical equipment in buildings.

8.4.1 Standardisation of Equipment

The use as far as possible of standard items such as switchgear will help both in buying, stockholding and replacement of components on the most economic and convenient basis.

8.4.2 Establishment of Records on Breakdown

Initially this may be on a simple log book or card system. This information should give some idea of which plant requires attention and at what intervals. It may also lead to improvements to the plant itself which will reduce the frequency of future failures.

8.4.3 Frequency of Maintenance

This requires careful organisation to ensure that it fits in with operational requirements. All planned maintenance should therefore have been agreed with the relevant operation manager prior to implementation.

8.4.4 Economic of Routine Maintenance

It may not be economic or practical to include some equipment in a scheduled routine although safety inspections will still need to be carried out. Examples of low priority maintenance are equipment that is not subject to breakdown, e.g. electric heater, and equipment that would cause little or no interference with operational routine and could be repaired or replaced at any time.

In some cases it may be found that as little as 25% of the plant needs to be maintained on a scheduled routine throughout the year. While the setting up of a successful maintenance/operation is not an easy task, the economic advantages can be considerable.

8.4.5 Upgrading to More Efficient Plant

Energy saving can be achieved by changing the type of equipment in use, for example;

- Replacement of less efficient lamps with more energy efficient lamps, e.g. T12 fluorescent lamp to new T8 lamp.
- Replacing electro-mechanical control devices to electronic systems.
- Installing new high efficiency motors to replace old motors particularly where extended duty operations prevail.
- Retrofitting VSDs for flow control of fans or pumps.

The economics of changing inefficient existing systems, which are continuing to provide a satisfactory operational performance, obviously requires careful consideration. Not only the costs of new equipment need to be understood, but also equipment life can have a significant impact on the overall financial viability of any proposed changes.

Energy Efficiency  **EMSD**

Electrical & Mechanical Services Department

Tel: (852) 1823 Fax: (852) 2890 6081

Website: www.emsd.gov.hk

e-mail: hkeersb@emsd.gov.hk