The Hong Kong Voluntary Energy Efficiency Labelling Scheme for

Electronic Ballasts

January 2010

Energy Efficiency  **EMSD**

Electrical and Mechanical Services Department

3 Kai Shing Street, Kowloon, Hong Kong

Homepage: <http://www.emsd.gov.hk>

CONTENTS

Section	Title	Page
1.	Purpose-----	1
2.	Background-----	1
3.	Scope -----	2
4.	Definitions -----	2
5.	Technical Standards-----	5
6.	Test Methodology-----	8
7.	Energy Label-----	11
8.	Testing Facilities, Laboratories and Accreditation Bodies -----	12
9.	Registration and Participation -----	14
10.	Legal Provisions-----	17
11.	Compliance Monitoring and Inspection-----	18
12.	Complaints and Appeal-----	20
13.	Maintenance of Scheme-----	21
14.	Future Development-----	21

ANNEXES

- 1 Energy Label Format
 - 2 Proforma Letter of Invitation
 - 3 Proforma Letter of Application
 - 4 Information to be Submitted to Energy Efficiency Office
 - 5 Proforma Letter of Acceptance
 - 6 Proforma Letter of Rejection
 - 7 Flow Chart for Registration
-

1. Purpose

This set of document is intended to give a general description on the introduction of the Hong Kong Voluntary Energy Efficiency Labelling Scheme (EELS) for Electronic Ballasts.

2. Background

The Nature of Energy Efficiency Labelling Scheme

- 2.1 The EELS is an energy conservation initiative that the Government of the Hong Kong Special Administrative Region (HKSAR) has adopted. Under the scheme, certain common types of household appliances and office equipment will incorporate an energy label that serves to inform consumers of the product's energy consumption and efficiency. Consumers should then be able to take those factors into account in making their purchasing decision.

Objectives of Energy Efficiency Labelling Scheme

- 2.2 The concept of EELS has been developed and implemented in several forms and in different stages of development. In some countries, it is a compulsory requirement for certain kinds of electrical appliances to be provided with an energy label before they can be put on the market. The labelling requirements may apply to equipment such as household refrigerators, washing machines, room coolers, clothes dryers, compact fluorescent lamps, storage water heaters, etc. The EELS generally aims to achieve the following:

- greater public awareness of energy conservation and environmental improvement needs;
- provision of readily available, pre-purchase information on energy consumption and efficiency data, where applicable, to enable ordinary consumers to select more energy efficient products;
- stimulation to the manufacturers/market for phasing out less energy efficient models; and
- actual energy savings and environmental improvements, etc.

- 2.3 Hong Kong also aims at achieving the above objectives and the Hong Kong Voluntary EELS now covers eighteen types of household appliances and office equipment. Ten

types of which are electrical appliances and seven types of office equipment. There is also one type of gas appliance for domestic gas instantaneous water heaters. The scope of EELS has also been extended to cover petrol passenger cars.

3. Scope

- 3.1 The scheme will only apply to the manufacturers and importers (local agents, retailers and the related parties) who have participated in the voluntary scheme.
- 3.2 The scheme commenced on 23 December 2004. The revision of the scheme has been implemented from January 2010 and will expire on 31 December 2012 when re-registration is necessary.
- 3.3 The scope of application covers all *new* registered appliances to be sold in Hong Kong with effect from the date that is declared by the participant but does not cover second-hand products, products already in use, under trans-shipment or export, etc.
- 3.4 The scheme will be operated as a 'Recognition Type' labelling system. All participating appliances will be recognised and registered, provided that they can meet certain energy efficiency and performance requirements as stipulated in the scheme.
- 3.5 The provisions of this scheme shall apply to electronic ballasts that are designed for standard fluorescent lamps (for linear, circular and compact types), HID lamps including high pressure sodium (SON) lamps and metal halide lamps. The electronic ballasts must be capable of being powered from either a 220V 50Hz AC supply or an appropriate DC power source.
- 3.6 Electronic ballasts with dimmable facility may also qualify under this scheme as far as they are measured and tested at their full output conditions.

4. Definitions

Unless otherwise specified, the following definitions shall apply throughout this document:

<i>Authority</i>	means the Electrical & Mechanical Services Department, the Government of the Hong Kong Special Administrative Region (HKSAR).
<i>ballast lumen factor</i>	means a ratio of the light output of the lamp when the ballast under test is operated at its rated voltage compared with the light output of the same lamp operated with the appropriate reference ballast supplied at its rated voltage and frequency.
<i>circuit power factor</i>	means the power factor of the combination of a ballast and the lamp or lamps for which the ballast is designed.
<i>Director</i>	means the Director of Electrical & Mechanical Services Department, the Government of the Hong Kong Special Administrative Region.
<i>electronic ballast</i>	means a ballast involving high frequency switching that is controlled by active components (transistors, thyristors, and the high frequency oscillator), and with the lamp ballasting impedance provided by a series capacitive or inductive reactance appropriate for the high switching frequency.
<i>Government</i>	means the Government of the Hong Kong Special Administrative Region.
<i>inspecting officer</i>	means the officer authorized by the Director to carry out inspection on appliances.
<i>IEC</i>	means the International Electrotechnical Commission.
<i>ISO</i>	means the International Organization for Standardization
<i>label</i>	means the energy label as described in Section 7 of this document.
<i>participant</i>	means the manufacturers, importers or the retailers of appliance participating in the scheme.

<i>rated voltage</i>	means the voltage marked on the ballast.
<i>rated wattage</i>	means the wattage marked on the ballast.
<i>recognized laboratory</i>	means a laboratory that complies with the requirements as stated in Section 8 of this document and is acceptable to the Authority for carrying out tests and issuing test reports on electronic ballasts.
<i>reference ballast</i>	means the special ballast designed for the purpose of providing comparison standards for testing ballasts and for selecting reference lamps. It is essentially characterized by the fact that at its rated frequency it has a stable voltage/current ratio which is relatively uninfluenced by variations in current, temperature and magnetic surroundings
<i>reference lamp</i>	means lamp selected for testing ballasts which, when associated with a reference ballast under specified conditions, has electrical characteristics which are close to the nominal values as stated in the relevant lamp standard for that particular type of lamp
<i>scheme</i>	means the Hong Kong Voluntary Energy Efficiency Labelling Scheme for electronic ballasts.
<i>total circuit power</i>	means a total power dissipated by ballast and lamp in combination, at rated voltage and frequency of the ballast.

5. Technical Standards

Energy Efficiency Specifications for Qualifying Products

- 5.1 Any electronic ballasts that are marketed to the consumer as such and meet the definition in Section 3.5 are eligible for the application of EELS for electronic ballasts. As mentioned in Section 3.6, this scheme also covers electronic ballasts with dimmable facility as far as they are measured and tested at their full output conditions.
- 5.2 Only for those products that meet the following criteria may qualify to obtain the energy label.

Performance Requirements

- 5.3 All electronic ballasts shall comply with IEC 60929, AC-supplied electronic ballasts for tubular fluorescent lamps - Performance requirements, or its equivalent.

Methods for Calculating the Maximum Allowable Power Consumption

- 5.4 The energy efficiency of the ballast-lamp circuit is determined by the total input power into the circuit. This is a function of the lamp power and of the type of ballast; for this reason, the maximum allowable power consumption of a given ballast is defined as the maximum ballast-lamp circuit power, for each lamp power and ballast type.
- 5.5 To calculate the maximum allowable consumption of a given ballast, it must therefore first be allocated to the appropriate category from the following list:

<u>Category</u>	<u>Description</u>
1	Electronic Ballast for linear fluorescent lamp type (e.g. T8 & T5 lamps)
2	Electronic Ballast for compact 2 tubes fluorescent lamp type
3	Electronic Ballast for compact 4 tubes flat fluorescent lamp type
4	Electronic Ballast for compact 4 tubes fluorescent lamp type
5	Electronic Ballast for compact 6 tubes fluorescent lamp type
6	Electronic Ballast for compact 2 D fluorescent lamp type
7	Electronic Ballast for circular fluorescent lamp type
8	Electronic Ballast for HID lamp type (e.g. high pressure sodium, metal halide lamps, etc.)

5.6 Under these category arrangements, the maximum allowable ballast-lamp circuit power consumption expressed in watt for those common lamp types is defined in Table 1 below. Whenever a lamp power of ballast falls between two values indicated in the below table, the maximum input power of ballast-lamp circuit should be calculated by linear interpolation between the two values of maximum input power for the two closest lamps power indicated in the table.

Table 1: Maximum allowable ballast-lamp circuit power for different lamp types

Ballast Category	Rated Lamp Power		Maximum Allowable Power Consumption
	50 Hz	High Frequency (HF)	
(for linear fluorescent lamps)	4 W	3.4 W	≤ 6 W
	6 W	5.1 W	≤ 8 W
	8 W	6.7 W	≤ 11 W
	13 W	11.8 W	≤ 15 W
	15 W	13.5 W	≤ 16 W
	18 W	16 W	≤ 19 W
	30 W	24 W	≤ 31 W
	36 W	32 W	≤ 36 W
	38 W	32 W	≤ 38 W
	58 W	50 W	≤ 55 W
	70 W	60 W	≤ 68 W
	--	14 W	≤ 17 W
	--	21 W	≤ 24 W
	--	24 W	≤ 27 W
	--	28 W	≤ 32 W
	--	35 W	≤ 39 W
	--	39 W	≤ 43 W
--	49 W	≤ 55 W	
--	54 W	≤ 60 W	
--	80 W	≤ 88 W	

Ballast Category	Rated Lamp Power		Maximum Allowable Power Consumption
	50 Hz	High Frequency (HF)	
2 (for compact 2 tubes fluorescent lamps)	5 W	4.5 W	≤ 7 W
	7 W	6.5 W	≤ 9 W
	9 W	8 W	≤ 11 W
	11 W	10 W	≤ 14 W
	13 W	12 W	≤ 16 W
	18 W	16 W	≤ 19 W
	24 W	22 W	≤ 25 W
	36 W	32 W	≤ 36 W
	--	40 W	≤ 45 W
--	55 W	≤ 61 W	
3 (for compact 4 tubes flat fluorescent lamps)	18 W	16 W	≤ 19 W
	24 W	22 W	≤ 25 W
	36 W	32 W	≤ 36 W
4 (for compact 4 tubes fluorescent lamps)	10 W	9.5 W	≤ 11 W
	13 W	12.5 W	≤ 14 W
	18 W	16.5 W	≤ 19 W
	26 W	24 W	≤ 27 W
5 (for compact 6 tubes fluorescent lamps)	18 W	16.5 W	≤ 19 W
	26 W	24 W	≤ 27 W
	--	32 W	≤ 36 W
	--	42 W	≤ 47 W
6 (for compact 2 D) fluorescent lamps)	10 W	9 W	≤ 11 W
	16 W	14 W	≤ 17 W
	21 W	19 W	≤ 22 W
	28 W	25 W	≤ 29 W

Ballast Category	Rated Lamp Power		Maximum Allowable Power Consumption
	50 Hz	High Frequency (HF)	
	38 W	34 W	≤ 38 W
	--	55 W	≤ 61 W
7 (for circular fluorescent lamps)	22 W	19 W	≤ 22 W
	32 W	30 W	≤ 35 W
	40 W	32 W	≤ 37 W
	--	22 W	≤ 26 W
	--	40 W	≤ 45 W
	--	55 W	≤ 61 W

5.7 In accordance with the information shown in Table 1, the ballast takes advantage of the unique feature of a fluorescent lamp whereby greater efficacy is obtained at high operating frequency. The overall lighting system efficacy can be increased by 20 to 30 percents due to the improvement of lamp efficacy at high frequency operation and the reduction of circuit power losses. The efficacy at high frequency operation is increased by about 10%, thereby enabling the lamp to be operated at a lower input power than at 50 Hz mains power frequency. Taking an example for a 36W lamp (Category 1), it normally consumes more than 45W total circuit power. But when applying with electronic ballasts, only 36W is consumed for the same light output. The net effect proves that in a typical luminaire, the same amount of useful light output is maintained at a comparatively lower input of power.

Other Technical Requirements

5.8 The operating frequency for all electronic ballasts should be above 20 kHz to be above the human audibility. In addition, taking into consideration that the frequency range from 30 to 40 kHz is more or less reserved for IR systems, the operating frequency for all electronic ballasts should be designed to avoid the said range.

6. Test Methodology

General

6.1 All test standards and specifications specified in this document are only related to checking compliance with the energy efficiency and general performance requirements. It is not the intention of this document to detail out the test standards and requirements

for checking compliance with the Electrical Products (Safety) Regulation of the HKSAR. The participant should conduct appropriate tests, where necessary, in addition to those specified in this document in order to obtain Certificates of Safety Compliance for his appliances.

Compliance with Safety Requirements

- 6.2 The testing standards for checking compliance with the safety requirements are based on IEC 61347-2-3, Lamp control gear - Part 2-3: Particular requirements for a.c. supplied electronic ballasts for fluorescent lamps, or its equivalent. For detailed requirements and procedural descriptions, one should refer to the respective standard.
- 6.3 To the extent that definitions in the IEC standards do not conflict with the definitions of this document, the definitions in the aforesaid standards shall be included.

Test Conditions

- 6.4 For all ballast-lamp circuits, the test conditions shall be as follows:

Supply Voltage	220 ($\pm 1\%$) Volts AC, 50 Hz ($\pm 0.5\text{Hz}$)
Total Harmonic Distortion (Voltage)	< 2% THD
Ambient Temperature:	25 °C \pm 5 °C

Testing Methodology

- 6.5 The measuring method for the total input power of the ballast-lamp system shall make reference to the European Standard EN 50294. In accordance with EN50294, the measurement of the total input power should be set up as follows:

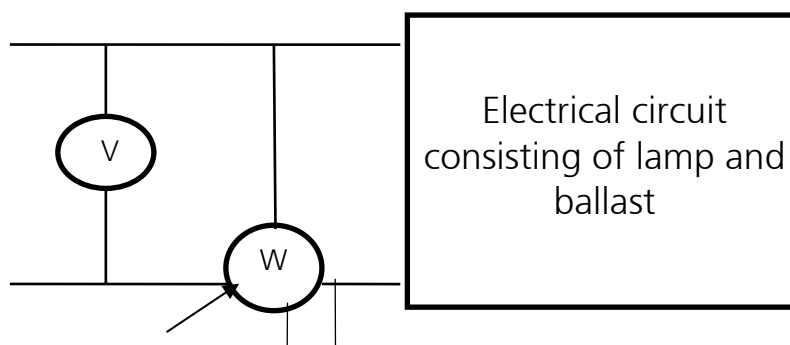

Measuring input power with wattmeter

-
- 6.6 The testing method is primarily aimed at measuring the total input power for the ballast-lamp circuit under tested. The tested ballast shall be operated with an appropriate reference lamp and the total input power, and lumen output are compared to the reference circuit using reference ballast and the same reference lamp. If measurement of lumen output is not feasible, the measurement of lamp power is also acceptable for comparison purposes.
- 6.7 The total circuit power and lamp lumen output (or lamp input power) is normalized back to standardized levels for comparison purposes. This standard was specifically developed by CELMA (Federation of National Manufacturers Associations for Luminaires and Electrotechnical Components for Luminaires in the European Union) and use for the test method to determine the ballast energy efficiency. The scope of the standard covers double and single capped fluorescent lamps and their ballasts. The standard mandates that a ballast lumen factor be declared by the manufacturer has to be in the range between 0.925 and 1.075 for electronic ballasts.
- 6.8 The corrected total circuit power and the lamp lumen output (or lamp input power) are measured for both tested and reference circuits. The total input power for the tested ballast/lamp circuit is corrected by the ratio of the lumen output for the reference circuit to the lumen output of the tested circuit. Alternatively, the total power could also be corrected by the ratio of the nominal lamp power (lamp data sheet) for the reference circuit to the measured lamp power of the test circuit.

7. Energy Label

General

- 7.1 Energy labels are classified into the following two types:
- (a) Verification label; and
 - (b) Information label.
- 7.2 A verification label indicates the appliance meets the energy performance standards as required by the scheme. It is a compulsory requirement for participant to affix this label to his registered appliances.
- 7.3 An information label contains information to guide the general public to contact the Authority regarding enquires about the scheme. The affixation of this label to registered appliances is optional.

Label Location

- 7.4 The labels should be self-adhesive and affixed to the appliance package at a prominent location. The participant should ensure that the verification label appears on every registered appliance on display or sale and should be easily visible.

Colour Scheme & Dimensions

- 7.5 The labels should be printed on material with white-coloured background and should have colour schemes and dimensions as shown in Annex 1. It should be printed in English and in Chinese.

Paper Quality

- 7.6 If the label is to be affixed on an electronic ballast package for display, the paper used for the label should be durable and possess good wear and tear characteristics.

8. Testing Facilities, Laboratories and Accreditation Bodies

- 8.1 The testing is carried out either by independent test institutes or by the manufacturers or by importers themselves at their own test facilities. The Authority will accept the results and certificates issued by the test laboratory, which fulfills one of the following criteria as specified in Clause 8.2, 8.3 or 8.4.
- 8.2 The laboratory is accredited by the Hong Kong Accreditation Service (HKAS) for the relevant test under the Hong Kong Laboratory Accreditation Scheme (HOKLAS) or a scheme with which HKAS has concluded a mutual recognition agreement*, and the results are issued in a test report or certificate bearing the accreditation mark ;
- 8.3 The Authority will also consider the following arrangements:
- (a) Self-certification by original manufacturers that the operations of their in-house laboratories satisfy the requirements of ISO/IEC 17025; and
 - (b) The manufacturers are currently operating according to a recognized international quality system (such as ISO 9001); and
 - (c) The manufacturer's in-house laboratories had been successful in carrying out tests on electronic ballasts and where these tests had been evaluated and certified by internationally recognised third party certification organisations.
- 8.4 The Authority will also consider test results issued by a laboratory which is accredited by HKAS or is accredited by an accreditation body which has concluded a mutual recognition arrangement with HKAS for testing laboratories for laboratory testing of electrical and mechanical appliances other than testing based on the technical standards stipulated in this scheme; if the laboratory can demonstrate their capability of carrying out tests on electronic ballasts in accordance with technical methods.

Laboratory Accreditation

- 8.5 The Authority takes cognizance of the need to ensure acceptable and compatible quality standards of testing laboratories, and considers that they need to be accredited by some independent bodies.
- 8.6 The criteria of accreditation should be based on ISO/IEC 17025 and accreditation bodies should operate in accordance with ISO/IEC 17011.

-
- 8.7 The Authority will recognize accreditation granted by the HKAS under the Hong Kong HOKLAS and by overseas accreditation bodies which have concluded mutual recognition arrangements with HKAS for accreditation of testing laboratories. The Authority will consider accreditation by other bodies on a case-by-case basis.

Energy Efficiency Verification Service

- 8.8 An increasing number of countries now accept, as proof of product conformance, energy efficiency verification services provided by third-party organisation that has been accredited as a certification organisation. In accordance with this trend, the Authority will consider seriously test results that have been evaluated and verified against the energy performance standards of the scheme by reputable third-party certification organisations.

Note: *HKAS has concluded mutual recognition arrangements with **fifty-eight** overseas accreditation bodies for testing laboratory accreditation, namely, **UKAS** of the United Kingdom, **NATA** of Australia, **A2LA**, **NVLAP**, **IAS** and **L-A-B** of the United States, **IANZ** of New Zealand, **RvA** of Netherlands, **SAC** of Singapore, **BMwa** of Austria, **BELAC** of Belgium, **DANAK** of Denmark, **FINAS** of Finland, **COFRAC** of France, **DAP**, **DACH** and **TAG** of Germany, **INAB** of Ireland, **ACCREDIA** of Italy; **NA** of Norway,, **ENAC** of Spain, **SWEDAC** of Sweden, **SAS** of Switzerland, **CNAS** of People's Republic of China, **TAF** of (Taiwan,China), **CAI** of Czech Republic, **INMETRO** of Brazil, **IAJapan**, **JAB** and **VLAC** of Japan, **KOLAS** of Korea, **SANAS** of South Africa, **SCC** of Canada, **NABL** of India, **BoA** of Viet Nam, **LA** of Lithuania, **SNAS** of Slovakia, **KAN** of Indonesia, **ISRAC** of Israel, **DSM** of Malaysia, **ema** of Mexico, **PNAC** of Pakistan, **PAO** of Philippines, **NSC-ONAC**, **DSS** and **DMSc** of Thailand, **TUNAC** of Tunisia, **TURKAK** of Turkey, **OAA** of Argentina, **ONARC** of Cuba, **NLAB** of Egypt, **EAK** of Estonia, **ESYD** of Greece, **LATAK** of Latvia, **PCA** of Poland, **SA** of Slovenia, etc. The list of mutual recognition arrangement partners may change from time to time and the up-to-date list is available from the HKAS website of www.info.gov.hk/itc/hkas. Partners to these arrangements recognise the accreditations granted by one another as equivalent.*

9. Registration and Participation

Registration Procedures

9.1 All manufacturers, importers and the other parties involved in the electronic ballasts business are welcomed and encouraged to participate in the scheme. For some known manufacturers and importers, invitation letters will be issued to them. However, any party may submit their applications for registration no matter whether they are invited or not.

9.2 The proforma letter of invitation is shown in Annex 2.

9.3 Applicant should submit formal application to

*Chief Engineer /Energy Efficiency A
Energy Efficiency Office
Electrical & Mechanical Services Department
3 Kai Shing Street, Kowloon
Hong Kong*

by means of an application letter through mail, facsimile or electronic mail.. In order to ensure effective implementation of the scheme, the applicant must be committed to fully comply with the duties, responsibilities and obligations set out in this scheme. The proforma letter of application as shown in Annex 3 details the aforesaid obligations and should be used for application. To facilitate the application process, the application form can be downloaded from EMSD website.

Information/Documents to be Submitted for Registration

9.4 Each make and model of an electronic ballast participating in the scheme should be provided with a test report issued by a recognized laboratory. The test report should contain energy efficiency test and performance test results. The details of the technical information to be submitted together with the application are listed as follows:-

(a) Information on the company:

Name, Address, Telephone number, Fax, Contact person, E-mail address, Importer, Distributor, etc.

(b) Products to apply for participating in the scheme:

Names of products, types, brand names, models, countries of origin

-
- (c) Parties that will be responsible for making and fixing the Energy Labels;
- (d) Commencement date to affix energy labels on appliance package
Year_____, Month_____
- (e) Documentary proof that the participating electronic ballast(s) comply with IEC 61347-2-3, Lamp control gear - Part 2-3: Particular requirements for a.c. supplied electronic ballasts for fluorescent lamps, and the Electrical Products (Safety) Regulation of the HKSAR,
- (f) Detailed test reports with electronic ballasts shall provide at least the following relevant technical data for the participating appliance:
- Testing conditions (i.e. ambient temperature, supply voltage and frequency);
 - Lamp lumen output/ lamp power for the reference circuit and the test circuit;
 - Reference ballast power and test ballast power loss;
 - Corrected total circuit power for the reference circuit and and test circuit;
 - Operative frequency;
 - Power rating at HF operation; and
 - Comparison between measurement of lamp power and maximum allowable power consumption.
- (g) Miscellaneous Technical Information:
- Product information catalogue
 - Technical Specification
 - Others

Notes: Company's name and chop should be stamped on all the documents provided.

The above information can also be found in Annex 4, information to be submitted to Energy Efficiency Office.

Acceptance of Registration

- 9.5 On receipt of the application, the Authority will verify whether the electronic ballasts under application meets the energy efficiency and performance requirements based on the submitted data. The accuracy of the submitted data, their inconsistencies and non-compliance will be dealt with in accordance with Section 11.

-
- 9.6 If the application is accepted, the participants will be notified of the result in writing within 17 working days. The participants will then be allowed to affix the energy label onto the 'registered' appliances package. Both manufacturers and importers of the registered appliances should ensure that the energy labels are correctly printed and affixed on the appliances package in accordance with Section 7. The performa letter of acceptance is shown in Annex 5.
- 9.7 If the application is rejected, the notification letter as shown in Annex 6 will also be given in 17 working days.
- 9.8 The flow chart for registration is shown in Annex 7.

Participant's Duties, Responsibilities and Obligations

- 9.9 The participant is obliged to:
- (a) submit application and information including test results in accordance with format and procedures set out in Sections 9.3 & 9.4;
 - (b) conduct tests via recognized laboratories and to comply with the specified test methodology and classification scheme;
 - (c) produce and affix energy labels at his own costs;
 - (d) fully inform other sales agents in his distribution network once the particular make and model of an appliance is registered under the scheme;
 - (e) allow random/ad-hoc inspection to be conducted by persons authorized by the Authority on registered appliance at his premises;
 - (f) conduct re-test(s) at his own costs at some recognized laboratories, if non-compliance is found on the appliance. The result of re-test(s) shall reach the Authority within the prescribed period of time specified by the Authority;
 - (g) inform the Authority of any change in the technical information and data that were previously submitted to the Authority together with the application letter;
 - (h) accept the fact that if appliance fails to perform in accordance with the requirements as given in Sections 5 and 6 and this cannot be readily rectified, the Authority may order it be de-registered from the scheme; and
 - (i) remove within three months all energy labels from appliances which had been de-registered from the scheme.

-
- 9.10 The details of the registered appliances will be kept in a register maintained by the Authority. The registration records will be regularly uploaded and maintained in the EMSD Internet for public and interested parties for access and information.

Termination

- 9.11 Under circumstances of poor performance such as:
- (a) (repeated) failure to fulfill obligations set out under Section 9.9; or
 - (b) in any other case where the Director is of the opinion that registration of an appliance is contrary to the public interest.

The Authority may de-register an appliance from the scheme with immediate effect by giving the participant notice in writing. Once an appliance is de-registered, no one is allowed to fix an energy label on it. However, participant will normally be given a grace period of three months to remove all labels from the de-registered appliances.

De-registration may occur even when there is no legal action taken under either the Trade Description Ordinance (Cap. 362) or the Copyright Ordinance.

- 9.12 Participant who decides to discontinue participating in the scheme or to withdraw any registered model from the registered appliances list shall give at least three months' advance notice to the Authority.

10. Legal Provisions

- 10.1 This is a voluntary scheme. However, a participant who abuses the scheme by giving false information on a label may contravene provisions of the Trade Description Ordinance.
- 10.2 No one could take advantage of the scheme by using the label on his appliances without authorization of the Authority as that may constitute an infringement of copyright under the Copyright Ordinance.

11. Compliance Monitoring and Inspection

Purpose

- 11.1 To uphold credibility of the scheme and to maintain continuous confidence of the consumers, compliance check on energy labels on those appliances participating in the scheme are needed. Also, to avoid the unsatisfactory situation that the non-participating parties taking advantage of the scheme by using unauthorized labels, we may also carry out suitable form of inspection on appliances which have not been registered under the scheme.

Scope

- 11.2 The scope of inspection includes sample checking and testing the following items:
- (a) whether the energy label is in fact placed on the registered appliance package;
 - (b) whether the energy label being displayed is of correct format in accordance with Section 7;
 - (c) whether energy label on the registered appliance package is in a prominent position;
 - (d) whether unregistered appliances display unauthorized energy labels;
 - (e) whether the registered appliance complies with the energy efficiency and performance requirements; and
 - (f) whether the data submitted by the participants are correct by random re-testing.
- 11.3 The participants will be requested to take immediate remedial action and report the follow-up action taken if non-compliance is found on their appliances.
- 11.4 If a registered appliance carrying energy label is found not meeting the requirements specified in accordance with the technical standards stipulated in Section 5, the participant will also be requested to repeat the performance tests at his own costs by an agreed testing laboratory.
- 11.5 If non-compliance is confirmed and no remedial action is to be taken by the applicant, the Authority may order it be de-registered from the scheme. Failure to remove energy labels from the de-registered appliances after the Director has withheld his authorization for using such labels may contravene the relevant ordinances.

Inspecting Officers

- 11.6 The Authority will authorize inspecting officers to carry out appliances compliance monitoring and inspection. The officers will carry proper identification cards that will be produced on request during their inspection operations. However, the officer will not inform the participants in advance of their intended inspection operation.
- 11.7 It is the participants' duty to allow the inspecting officers to gain access to their premises to carry out inspection.

Mode of Inspection

- 11.8 Inspections will be carried out on registered appliances under the scheme on random basis. Based on the record of the registration, random inspection programmes will be developed.
- 11.9 In addition to the random inspections, the inspecting officers will carry out ad-hoc inspections in response to complaints. The items to be inspected in such a case will depend upon the nature of complaint and may include all types of inspection as stated in Section 11.2.
- 11.10 Inspections will normally be carried out at the retail outlets and appliances showrooms. Where necessary, inspection will also be done at warehouses.
- 11.11 The inspection results will be properly recorded for future analysis as well as on evaluation of the effectiveness of the scheme.

12. Complaints and Appeal

- 12.1 The Authority will be responsible for dealing with complaints from participant and other parties against matters related to the scheme.

Complaints Handling Procedure

- 12.2 The Director shall ensure that complaints are properly recorded and handled without undue delay.
- 12.3 The Authority shall carry out preliminary investigation on complaints and reply to the complainants within a reasonable time. For complaints that require site inspection and laboratory test, the complainant shall be notified through an interim reply.
- 12.4 The Authority shall inform the complainant of the results or decisions made on the complaint.

Appeal Procedure

- 12.5 A participant who is aggrieved by a decision or action taken by the Authority may appeal to the Director in writing stating the reason for the appeal.
- 12.6 The Director may decide to suspend the decision or action given by the Authority from the day on which the appeal is made until such appeal is disposed of, withdrawn or abandoned unless such suspension would, in the opinion of the Director, be contrary to public interest.
- 12.7 The Director may by notice to the appellant require that appellant to attend meeting with him or his representative and provide documents and give evidence relevant to the appeal.
- 12.8 The Director shall notify the appellant of his decision and reasons for it. The decision will be final and binding.

13. Maintenance of Scheme

- 13.1 To ensure that the scheme can continue to operate effectively and efficiently after its introduction, a proper system of maintenance is needed.
- 13.2 The maintenance system consists essentially of:
- (a) Continuous updating of the lists of participants in the scheme as follows:
 - (i) Registered appliances with details such as registration number in the scheme, date of registration or de-registration if it occurs, energy efficiency data, performance data, make, model, category and other related information; and
 - (ii) Registered importers, manufacturers, local agents etc. in the distribution network with details such as address, date of registration or de-registration if it occurs, etc.
 - (b) Periodic review of the test methodology, and procedures for application registration and compliance monitoring, etc. to bring them in line with the latest needs of the manufacturers, importers and retailers, etc.
 - (c) Continuous evaluation of the effectiveness of the scheme and assessment of what changes are necessary.

14. Future Development

- 14.1 It is hoped that following implementation, the market will phase out appliances of low efficiency and public awareness of using energy efficient products and energy conservation will be improved.
- 14.2 As part of the Government's ongoing efforts to promote the efficient use and conservation of energy, it is opportune to introduce a mandatory EELS by the inclusion of energy consuming products in phases. In the initial phase, refrigerators, room coolers and compact fluorescent lamps are being considered in the proposed mandatory EELS.

ANNEXES

Energy Label Format

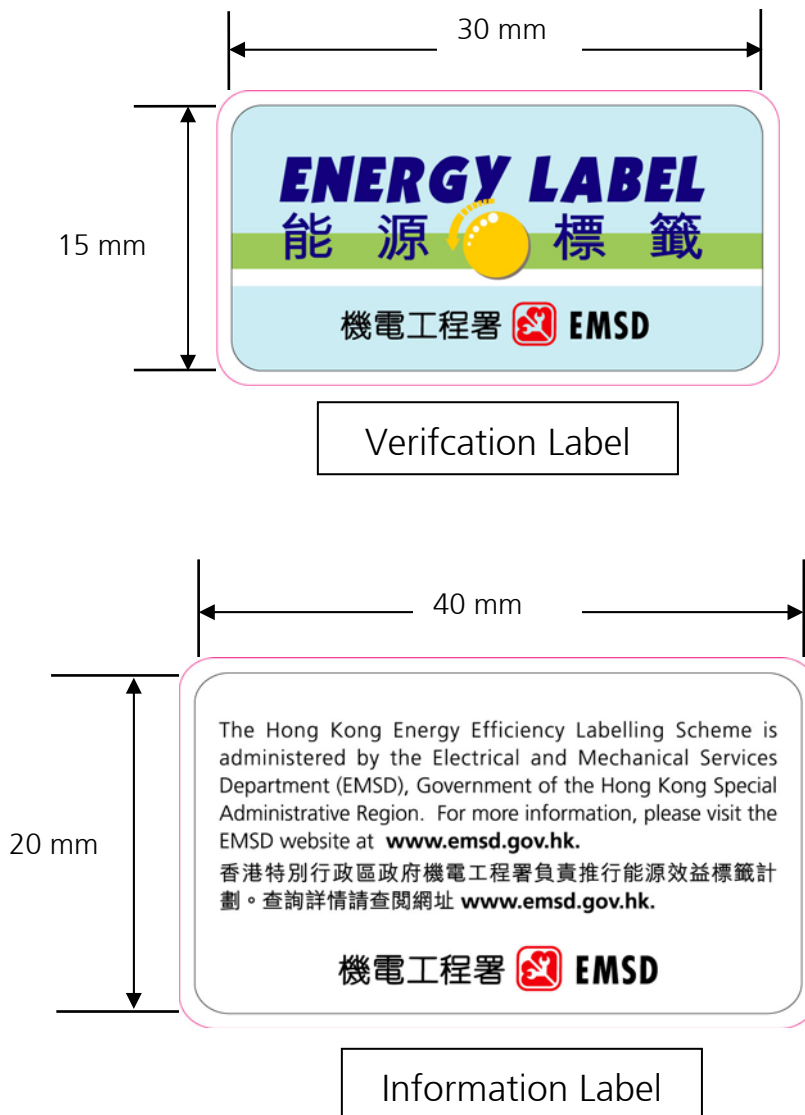

Soft copies of these labels can be obtained from Energy Efficiency Office, Electrical and Mechanical Services Department.

Proforma Letter of Invitation

Our ref. EEO/LB/29
Your ref.

Tel.
Fax.

Date

[Name and Address of
Manufacturers/Importers/Agents]

Dear Sir/Madam,

Invitation of Application for Registration to Participate in Voluntary Energy Efficiency Labelling Scheme for Electronic Ballasts

Having gone through the necessary consultations and duly considered the views from various concerned parties, the government has decided to introduce a voluntary energy efficiency labelling scheme for electronic ballasts to Hong Kong with effect from (_____). The details of the scheme^① have been finalized and I enclose herewith a guide of the scheme for your reference.

Being one of the major electronic ballasts manufacturers / importers / agents^② in Hong Kong, you are invited to participate in the scheme so as to take part in promoting public awareness in energy conservation and environmental improvement to Hong Kong. If you are interested to participate in the scheme, please apply in accordance with the proforma letter of application (Annex 3) and submit details including technical information in accordance with the attached Annex 4 to the 'Chief Engineer / Energy Efficiency A' at the following address.

Energy Efficiency Office
Electrical and Mechanical Services Department
3 Kai Shing Street, Kowloon
Hong Kong

Please be reminded to submit accurate test data to support your application. Under this Scheme, routine compliance monitoring and checking will be performed and if a registered electronic ballast is found to be non-compliant, we may consider deregistering the electronic ballasts from the Scheme.

Should you need further clarification or information, you are most welcome to contact the undersigned or Mr. _____, at the telephone number _____.

Yours faithfully,

for Director of Electrical & Mechanical Services

(Note: ^① 'scheme' means 'The Voluntary Energy Efficiency Labelling Scheme for electronic ballasts'
^② delete as appropriate)

Proforma Letter of Application

Your ref. EEO/LB/29
Our ref.

Tel.
Fax.

Date

Chief Engineer/Energy Efficiency A
Electrical & Mechanical Services Department
3 Kai Shing Street, Kowloon
Hong Kong

Dear Sir/Madam,

Application for Registration to Participate in Voluntary Energy Efficiency Labelling Scheme for Electronic Ballasts

Our company is the (manufacturer/importer/agent*) of _____ in Hong Kong. We support the introduction the labelling scheme to Hong Kong and would like to be one of the participants in the scheme to promote energy efficiency.

I understand fully the obligations and duties stated in the scheme and will comply with all relevant requirements, in particular those specified below:

- i) conduct tests via recognized laboratories and to comply with the specified test standards;
- ii) produce and affix specified labels at my own costs;
- iii) allow random/ad-hoc inspection to be conducted by persons authorized by the issuing Authority on registered appliance at my premises;
- iv) conduct re-test(s) at my own costs at some recognized laboratories, if the results of inspection suggest inaccurate energy label information being displayed. The result of re-test(s) shall reach the Authority within the prescribed period time specified by the Authority;
- v) inform the Authority of any change in the technical information and data that were previously submitted to the Authority together with the application letter; and
- vi) accept the fact that if appliance fails to perform in accordance with the required energy efficiency standards and performance as given in Section 5 and this cannot be readily rectified, the Authority may order it be de-registered from the scheme.

The details of information of those appliances which we intend to register with the Authority are shown in the attached document, (Annex 4) and are submitted herewith for your vetting.

Yours faithfully,

(Manufacturer/Importer/Agent's Name and Company Chop)

* *delete as appropriate*

Information to be Submitted to Energy Efficiency Office

1. Information on the company:
Name, Address, Telephone number, Fax, Contact person, E-mail address, Importer, Distributor, etc.

2. Product to apply for participating in the scheme:
Name of products, types, make, model references, countries of origin

3. Parties will be responsible for making and fixing the Energy Label

4. Commencement date to affix Energy Labels on appliance package
Year _____, Month _____

5. Detailed test reports providing at least the following relevant technical data for the participating appliances:
 - (a) Testing conditions (i.e. ambient temperature, supply voltage and frequency);
 - (b) Lamp lumen output/lamp power for the reference circuit and the test circuit;
 - (c) Reference ballast power and test ballast power loss;
 - (d) Corrected total circuit power for the reference circuit and and test circuit;
 - (e) Operative frequency;
 - (f) Power rating at HF operation; and
 - (g) Comparison between measurement of lamp power and maximum allowable power consumption.

6. Documentary proof that the appliance(s) comply with the Electrical Products (Safety) Regulation of the Hong Kong Special Administrative Region.

*Note: Company's name and chop should be stamped on the all documents provided.
All test reports submitted to the office should be certified true copy by appropriate organization.*

Proforma Letter of Rejection

Our ref. EEO/LB/29
Your ref.

Tel.
Fax.

Date

[
Manufacturers/Importers/Agents

]

Dear Sir/Madam,

Rejection of Application for Registration to Participate in Voluntary Energy Efficiency Labelling Scheme for Electronic Ballasts

With reference to your letter of application ref. _____ dated _____, I regret to inform you that your application for registration to participate in the scheme has not been accepted for the following reasons:-

1. _____ etc.

You are most welcome to submit new application again in future, when you have the necessary documents / information to support your application.

Yours faithfully,

for Director of Electrical & Mechanical Services

Flow Chart for Registration

