

T5 Lamps and Luminaires – The 3rd Generation in Office Lighting

Ir Martin WU Kwok-tin

Building Services Engineer, Energy Efficiency Office, EMSD

Abstract:

Hong Kong is a leading commercial and financial centre in Asia and the energy consumption is increasing substantially every year over the past ten years. The electricity consumption in the commercial sector is increasing at about 7% per annum and is the fastest growing sector. The Energy Efficiency Office of Electrical and Mechanical Services Department is actively exploring means to reduce energy consumption and a series of initiatives are being implemented to achieve the goal. One of the initiatives is to investigate advance and innovative energy saving technologies with a view to promote the wider use of these technologies in Government buildings. The investigation covers equipment for lighting, air conditioning, lifts and escalators. The paper will present a report of the technical background, the current status of our findings and our future research interests in office lighting using T5 lamps.

Keywords: Fluorescent Lamps; Ballasts; T5 Lamps & Luminaires; Pilot Project, Prospect

1. Introduction

The Energy Efficiency Office (EEO) of the Electrical & Mechanical Services Department (EMSD) has committed to use energy efficient lamps and luminaires for lighting installations for their Pilot Energy Management Opportunity (EMO) Implementation projects. The aim of this study is to investigate the feasibility of adopting the new generation of T5 (16mm dia.) fluorescent tubes together with appropriate electronic ballasts for use in fluorescent luminaires. The very small dimensions and weight of T5 lamps offer greater opportunities for luminaire design. The investigation will focus on the merits and demerits of luminaires with T5 lamps against those with conventional T8 or T12 lamps. All relevant background information and technical details of the new lamp type, electronic ballasts for the new lamps and the new luminaires design will be discussed in the paper. The results of one of our pilot projects using T5 luminaires will also be included.

2. Technical Information

The basic operating principle of fluorescent lamps and their associate control gears will briefly be introduced in this section.

2.1 Fluorescent Lamps

The fluorescent lamp, or low-pressure mercury vapour lamp, is by far the most widespread of all discharge lamp type used for general lighting nowadays. It is employed almost universally especially in office lighting. The introduction of

compact fluorescent lamps has led to its application in domestic buildings too. The most common type of fluorescent lamp is tubular linear in shape ranged from 600mm (18W) to 1500mm (58W) in length. The discharged tube has an electrode sealed into each end and is filled with an inert gas and a small amount of mercury, the latter being present in both liquid and vapour form. The inside of the tube is coated with a mixture of fluorescent powders. These convert the ultraviolet radiation of the mercury discharge into longer wavelengths within the visible range. Different fluorescent powders or ‘phosphors’ are available for any desired colour temperature and colour rendering characteristics.

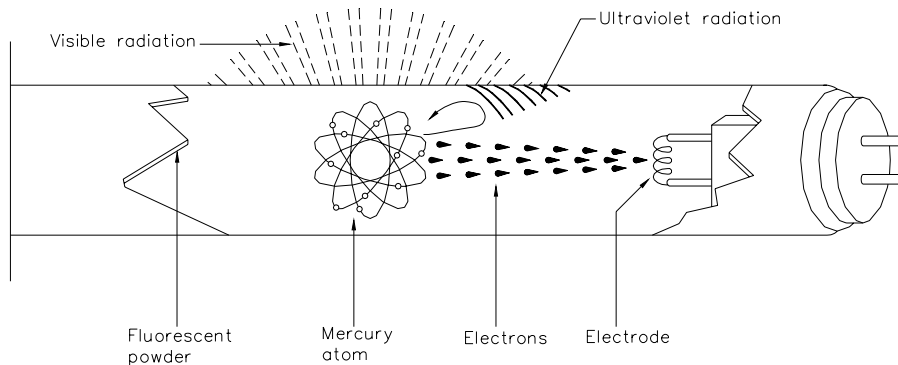

Fig. 1 Basic construction and operation of fluorescent lamp

Basically, the linear tubular fluorescent lamps have undergone three generations so far. They can be sub-divided as follows:

- a) The 1st generation is T12 lamp with a diameter of 38mm (1.5”) and with a length dictated by the wattage (20W, 30W, 40W and 65W). These so-called ‘old’ or ‘fat/thick’ lamps are stabilised by electromagnetic ballasts and have by now in most case been replaced by the T8 lamps. Efficacy is about 70 lm/W.
- b) The 2nd generation is T8 krypton-filled lamp with a diameter of 26mm (1”) and with a length dictated by wattage (18W to 70W). These so-called ‘thin’ lamps can be stabilised by both electromagnetic and electronic ballasts with extra benefit of improved efficacy and lumen maintenance. Efficacy is about 80 lm/W
- c) The 3rd generation is new T5 lamp with a diameter of 16mm (5/8”) and G5 base. T5 lamps have been available with outputs of 4W, 6W, 8W and 13W for over 30 years. However, these lamp types were mainly used for furniture, signage and table lighting. A few year ago, however, new T5 lamps with higher wattage were developed, which, owing to their superior luminous efficiency outputs (efficacy about 100 lm/W), represent serious competition for the classical fluorescent lamp. The standard wattage of the new T5 lamps is 14W, 21W, 28W and 35W. Enhanced economy is achieved by high frequency operation with electronic ballasts, which are specified in principle for these new lamp types. Owing to their slim shape, the new T5 lamps permit innovation in luminaire design as a further reduction in casing dimensions. In addition, the lamp length of all types is 50mm shorter than their T12/T8

counterparts and is dimensioned to enable them to fit exactly into the usual grid (600mm and 1200mm) of suspended ceilings.

2.2 Control Gear for Fluorescent Lamps

Unlike an incandescent lamp, a fluorescent lamp cannot be connected directly to the mains. Some device to limit the electric current flowing through it must be included in the circuit. This device can be electromagnetic ballast (conventional or low loss) with starter or electronic ballast operating at high frequency. To facilitate starting, the electrodes of most fluorescent lamps are preheated prior to ignition, which is accomplished by means of a preheat voltage.

The optimum functioning of fluorescent lamps largely depends on the properties of the control gear used. They cannot function properly on the mains supply voltage and certain electrical devices have to be incorporated into the lamp circuit. The control gear performs a number of functions:

- To limit and stabilise the lamp current.
- To ensure lamp operating continuously during zero crossing of voltage at each half cycle.
- To provide ignition voltage for initial lamp starting
- To supply controlled energy to pre-heat lamp electrodes during ignition.
- To fulfil other requirements such as ensuring high power factor, limiting harmonic distortion, suppressing EMI, limiting short-circuit and starting current, having long life, low losses and low noise level, etc.

2.2.1 Electromagnetic (Conventional and Low Loss) Ballasts

With the electromagnetic control gear system, various separate components including ballast, glow starter switch, capacitor and filter coil fulfil all the above requirements together with the lamp.

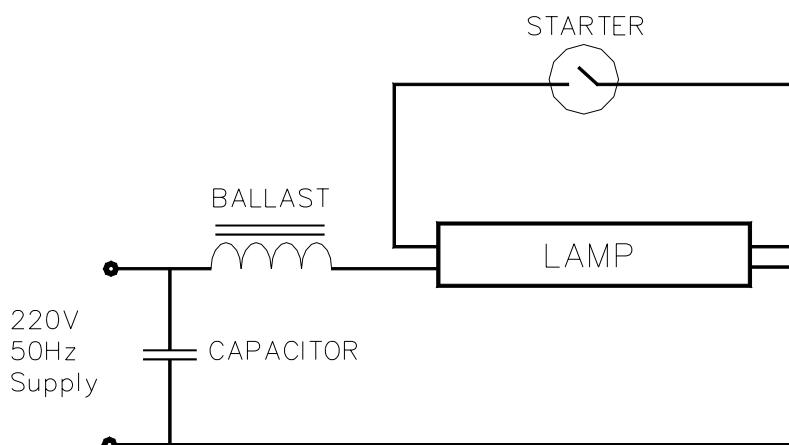

Fig. 2 Lamp circuit using electromagnetic ballast

This type of control gear involves a glow starter switch for preheating the filaments of the electrodes before discharge. When the supply voltage is applied, a small discharge occurs between the bimetal electrodes of the starter. The heat caused

by this discharge curves the bimetal electrode and closes the contact to complete the circuit. The electrodes of the lamp are then preheated for a certain period before the starter cools down and opens the circuit. At that instant, a high induced voltage that occurs on the choke coil of the ballast causes the fluorescent lamp to ignite. If ignition of the lamp fails at the first attempt, the same process above will be repeated until ignition succeeds to start.

After starting of the lamp, the ballast will function as a current limiting device connected in series with the lamp. Iron and copper losses occur in the ballast dissipated as heat to the room space. Typical ‘warm’ loss of conventional and low loss ballasts operating a 36W fluorescent lamp is 12W and 9W respectively. Normally, one set of control gear is required to operate one fluorescent lamp.

2.2.2 Electronic Ballasts

The basic construction of typical electronic ballast involves a low-pass filter, rectifier, buffer capacitor and a high frequency oscillator. Although the electronic ballast system is integrated into one single ‘black box’, its different functions and requirements can be divided into a number of individual blocks. The basic operation principle is that after passing a low-pass filter, the mains voltage at 50Hz power frequency is rectified in an AC/DC converter. This converter also contains the buffer capacitor, which is charged with a DC voltage. In the HF power generator this DC voltage is transformed into a HF voltage, which provides the power for the lamp controller. The ballast controller controls all these functions.

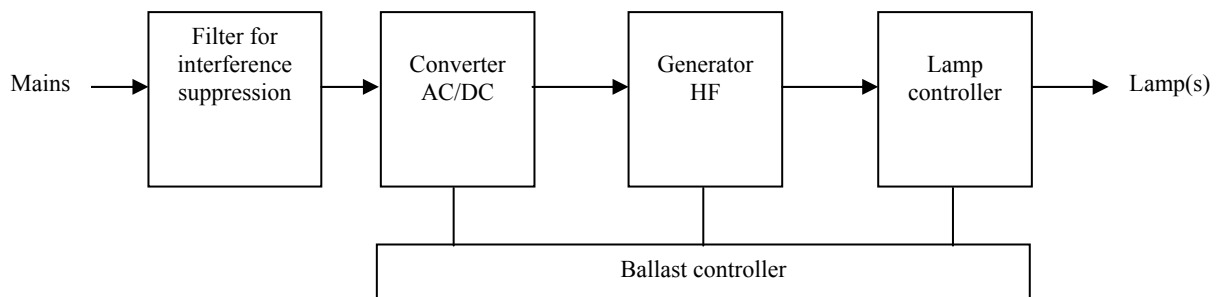

Fig. 3 Block diagram indicating main functions of electronic ballast

The ballast takes advantage of a characteristic of fluorescent lamp whereby greater efficacy is obtained at high operating frequency above 10kHz. The overall lighting system efficacy can be increased by 20 to 30 percents due to three main factors:

1. Improved lamp efficacy at high frequency operation.
2. Reduced circuit power losses.
3. Lamp operates closer to optimum performance in most enclosed luminaires.

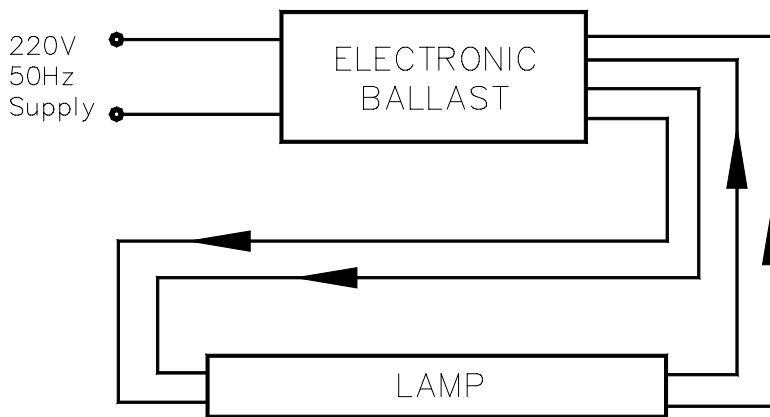

Fig. 4 Lamp circuit using electronic ballast

Efficacy due to high frequency operation is increased by about 10% thereby enabling the lamp to be operated at a lower input power than at 50Hz mains power frequency. For instance, a 36W 1200mm T8 lamp normally consumes a circuit power of 47W with conventional ballast, can now be run at 36W for the same light output. The net effect is that same useful light output is maintained at lower power input in a typical luminaire.

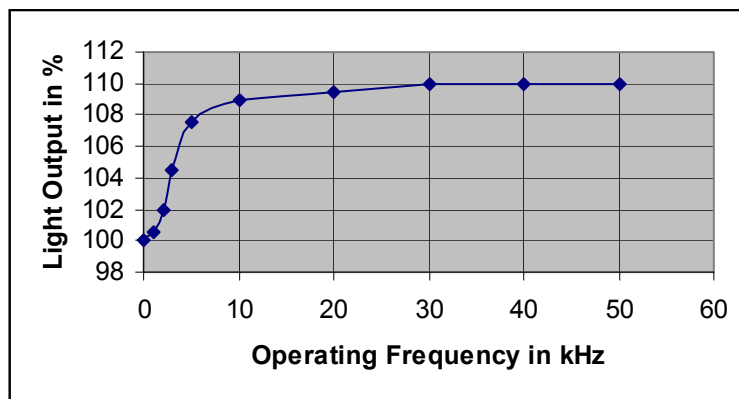

Fig. 5 Luminous flux of fluorescent lamp as a function of supply frequency at constant power

Ballast losses are reduced compared to electromagnetic ballast, as the solid-state circuit contains no conventional copper windings. In the case of a twin 1200mm 36W lighting circuit the losses can be reduced from 24W to a mere 6W when using electronic ballast. The overall achievement in a suitable luminaire, therefore, is an energy reduction in the region of 20% to 30%. These energy saving features enable lighting levels to be maintained with a dramatic cut in electricity costs. With less heat generated, the cooling load on air conditioning equipment will also be reduced.

Other benefits electronic ballast offered include:

- Rapid or instant starting of lamp without flickering.
- Single ballast can be designed to drive one, two, three or even four lamps.

- Increased lamp life due to lower lamp operating current.
- Quiet operation without audible noise.
- Dimmable version is also available.
- No visible flicker during operation.
- No stroboscopic effect and HF operation.
- Most modern design has lower total harmonic distortion (THD) than conventional ballast with or without power factor correction capacitor.
- High total power factor due to low THD and $\cos\theta$.
- Cooler ambient temperature inside luminaires for optimum operation of lamp, control gear, capacitor and batteries for emergency lighting.
- Low operating temperature and reduce carbonisation and blackening to luminaire and decoration in the vicinity.
- Less effect on variation of luminous flux due to mains supply voltage fluctuations.
- Much lighter in weight.

Unlike other T8 lamps, the new T5 lamps are especially designed for operation with electronic ballasts for greater efficiency. Table 1 below summarises the suitability of ballast types for various fluorescent lamp groups.

Table 1: Suitability of Ballast Types for various Fluorescent Lamp Groups

Lamp Group	Conventional Ballast	Low Loss Ballast	Electronic Ballast	Dimmable Ballast (Magnetic)	Dimmable Ballast (Electronic)
T12 (38mm)	√	√	X	√	X
T8 kryton-filled (25mm)	√	√	√	X	√
T5 (16mm)	X	X	√	X	√

2.2.3 Design of Luminaires

An important element in the design of luminaire is optical control. The purpose of optical design is to redirect the light from a bare source to the area where it is needed, to reduce the light in those zones where it may cause glare, and to provide a housing that is pleasing in appearance while, if necessary, protecting the lamp. Opal diffusers, prismatic controllers and parabolic specular reflectors are the most common types of optical control used in fluorescent luminaires.

For fluorescent luminaires with T5 lamps, the most effective means of optical control is parabolic reflection. The parabola is the most commonly used reflector contour: it is defined by the equation $y^2 = 4ax$ where a is the shortest distance of the focal point to the reflector. The most important optical property of the parabolic reflector is that if a line source is placed at its focus a parallel beam of light is obtained. Fig. 6 shows the beams of reflected light produced by a line source at focus of the parabolic reflector. In practice the ideal line source is difficult to obtain from fluorescent tube and the shape of the distribution curve depends on the size of the source in relation to the focal length and mouth width of the reflector. As the diameter of T5 tube is much smaller than its T8 and T12 counterparts, and is more closer to a line source, optical control of luminaires with T5 lamps and parabolic reflector can be more precise and efficient.

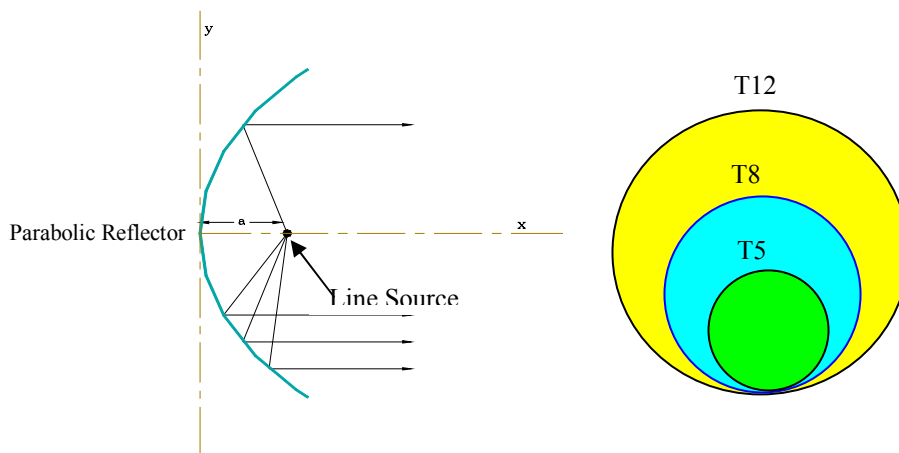

Fig. 6 Parallel beam produced by line source at focus of parabola & Relative Size of T12, T8 & T5 Lamps

3. Testing of Luminaire with 1 x 28W T5 Tube

A sample luminaire using 28W T5 tube was offered by Thorn Lighting (Hong Kong) Limited to Energy Efficiency Office, EMSD for general performance testing. The sample luminaire is a recessed modular type (1200mm x 125mm) complete with a 28W T5 lamp (Philips TL5 28W/835), an electronic ballast (Philips HF-P128 TL5 220-240) and aluminium parabolic reflectors specially designed for T5 lamp operation. Fig. 7 shows the physical size of the tested luminaire in relation to 28W T5, 36W T8 and 40W T12 lamps. The polar curve indicating the light distribution of the luminaire designed to CIBSE Cat. II for T5 lamp is also shown in Fig. 8.



Fig. 7 Physical Size of T5 Luminaire under tested as compared with T8 & T12

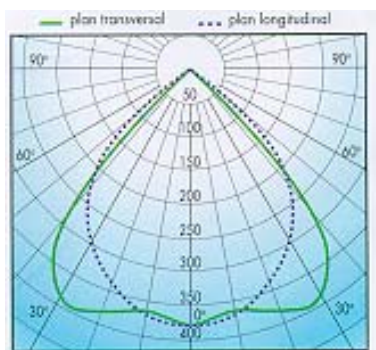

Fig. 8 Polar Curve of the tested Luminaire

3.1 Test Results

A lighting test rack was set up in EEO for mounting the luminaire under test. A digital luxmeter (Lutron LX-102) was used to measure illuminance in lux at a fixed test point directly underneath the luminaire for comparison purposes. A power harmonics analyser (Fluke 41B) together with an IBM notebook were used to record all electrical parameters including active power, apparent power, power factor, voltage, current and total harmonic distortion, etc. in the test. The computer printouts for the test and the catalogue of the luminaire were appended in Appendix 1 for information. Table 2 below summarises the test results of the 28W T5 luminaire as compared with its 36W T8 counterpart operating on conventional and electronic ballasts (with same lumen output).

Table 2: Test Results (Average Values) for 28W T5 Luminaire as compared with 36W T8 Luminaire with Conventional and Electronic Ballasts

	Current (A)	Circuit Power	Power Saved	Power Factor	THD (%)
36W T8 Luminaire with Conventional Ballast	0.4A	47W	0%	0.52	9%
36W T8 Luminaire with Electronic Ballast	0.16A	34W	28%	0.99	5%
28W T5 Luminaire	0.14	30W	36%	0.98	9%

4. Pilot T5 Lighting Project at Arsenal House

The pilot project included the replacement of the existing 320 sets 3 x 18W T8 600mm x 600mm recessed modular fluorescent luminaires in the office areas on 27/F, Arsenal House, with new 3 x 14W T5 600mm x 600mm recessed modular fluorescent luminaries, complete with electronic ballasts (1 for 3 lamps type) and parabolic reflector reflectors designed to CIBSE LG3, Cat. II. The lighting layout of the floor and the new luminaire used are shown in fig.9 and 10 below.

Table 3 and fig. 11 below show the test data of the existing 3x18W T8 luminaire removed from site.

Table 3 Electrical Parameters of the old 3x18W T8 luminaire

			Voltage	Current
Frequency	49.99	RMS	223.4	0.754
Power		Peak	312.7	1.095
W	90	DC Offset	0.2	-0.02
VA	168	Crest Factor	1.4	1.45
var	142	THD Rms	2.23	8.80
Peak W	244	THD Fund	2.23	8.84
Phase	58°lag	HRMS	5.0	0.66
Total PF	0.53	KFactor		1.51
DPF	0.53			

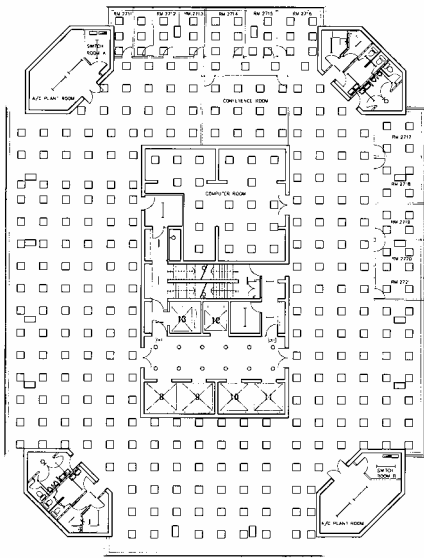

Fig. 9 Lighting layout at 27/F, Arsenal House



Fig. 10 New 3x14W T5 Luminaire used at Arsenal House

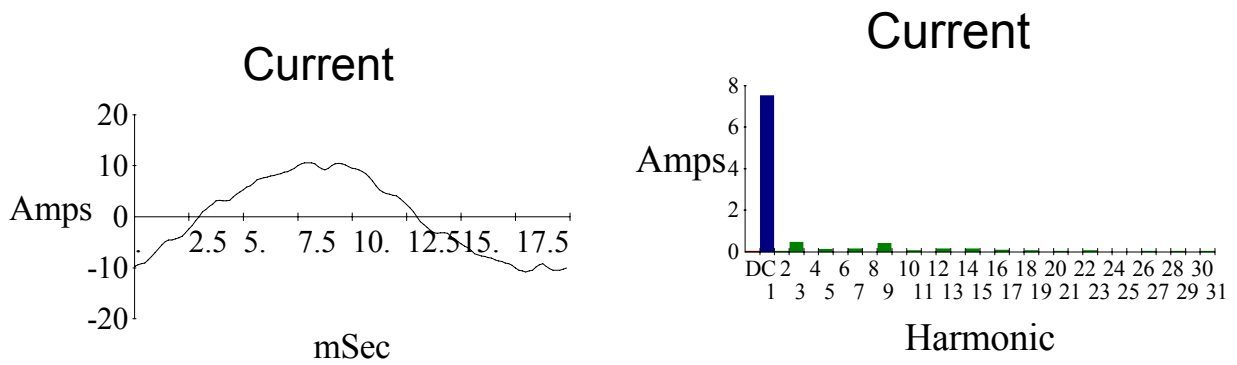

Fig. 11 Current waveform and harmonic content of the old 3x18W T8 luminaire

Table 4 and fig. 12 below show the test data of the new 3x14W T5 luminaire used in the project.

Table 4 Electrical Parameters of the new T5 luminaire

			Voltage	Current
Frequency	49.94	RMS	221.8	0.22
Power		Peak	308.5	0.316
W	48	DC Offset	0.0	-0.03
VA	49	Crest	1.39	1.44
var	7	THD Rms	2.30	8.60
Peak W	98	THD Fund	2.30	8.63
Phase	8° lead	HRMS	5.1	0.19
Total PF	0.99	KFactor		1.19
DPF	0.99			

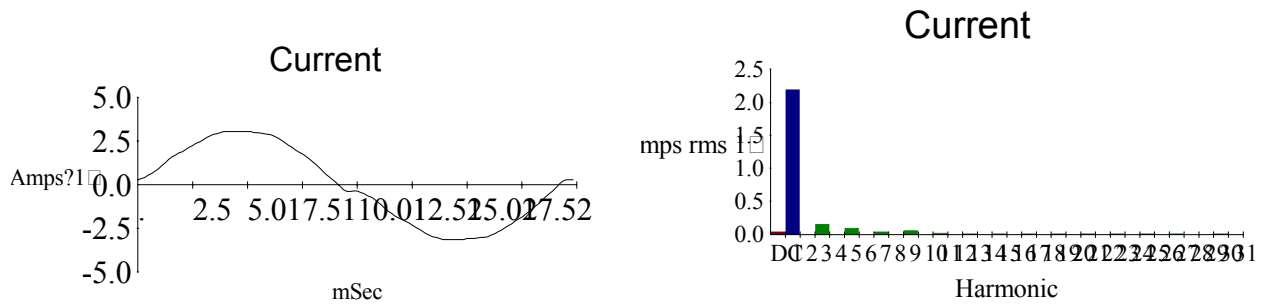

Fig. 12 Current waveform and harmonic content of the new T5 luminaire

Measurement on site before the lighting retrofit indicated that the floor had a total lighting load of 28kW and an average daily energy consumption of 470kWh. Each of the existing 3x18W T8 luminaire consumed 90W at a power factor of 0.53. The low power factor was mainly due to the under designed of the capacitors inside the luminaire (only one 5.5 uF capacitor was used for the whole luminaire). Table 5 below summarises the performance of the new T5 lighting installation as compared with the old lighting system.

Table 5 Summary table for the lighting retrofit at 27/F Arsenal House

	Existing T8 Lighting System	New T5 Lighting System	% difference
Active Power (kW)	28 kW	16 kW	- 42%
Power Factor.	0.53	0.99	+ 87%
T.H.D.	11%	8.6%	- 21.8%
Apparent Power (kVA)	52.8 kVA	16.2 kVA	- 69%
Reactive Power (kvar)	23.7 kvar	2.3 kvar	- 90%
Average Illuminance	450 lux	500 lux	+11%
Lighting Power Density	30 W/m ²	18 W/m ²	-40%

Based on the information above, the following observations could be drawn for this pilot T5 lighting retrofit project:

- ✧ The average daily lighting energy consumption measured on site before retrofit was 470 kWh. The average measured daily lighting energy consumption after retrofit was 270 kWh. An annual energy saving of 55,000 kWh is anticipated per floor.
- ✧ The power factor of the lighting circuits was greatly improved from 0.53 to 0.99, resulting in lower circuit current, less reactive power, smaller distribution loss and possible saving in demand charge.
- ✧ The reduction in reactive power of the lighting load in this floor is 21.4 kvar. The reduction of reactive power for the whole building will be 642 kvar if all 30 stories of offices/workshops are retrofitted with new T5 luminaires. This would

eliminate the requirement to add extra capacitor banks at the main distribution board for power factor correction.

- ✧ The average lighting power density before retrofit was 30 W/m^2 , which exceeds the maximum 25 W/m^2 as stipulated in the Lighting Code. The new lighting power density after retrofit was 18 W/m^2 .
- ✧ There was also a slight reduction in Total Harmonic Distortion (THD) of current, causing fewer problems to the power quality of the building.
- ✧ Due to improvement in the design of parabolic reflector and the more linear T5 light source, the utilisation factors of the new luminaire is higher. The average illuminance measured after retrofit was 500 lux, which was 11% brighter than the original lighting installation. However, the office ceiling appeared darker than before because of the Cat II luminaire designed for use in computer floor.

5. Conclusion & Recommendation

- 5.1 The new range of T5 tubes was developed for higher system efficiency and miniaturisation. With appropriate luminaire and parabolic reflector design, the T5 lamp offers higher utilisation of the available light on the working plane. As far as energy saving is concerned, the 28W T5 luminaire consumed only 30W circuit power and achieved a saving of 36% as compared with 36W T8 luminaire with conventional ballast.
- 5.2 The T5 lamps are specially designed for high frequency operation with electronic ballasts for higher efficiency and longer life (15,000 hrs.). Their shorter lamp length and thinner diameter (closer to a line source) give more luminaire design possibilities and they can be easily fitted into the common ceiling module systems (e.g. 600mm x 600mm, 600 x 1200mm, etc) without protruding into the adjacent ceiling grid. Fig. 13 shows the different in length and depth between a typical T5 luminaire and T8 luminaire with and without an extruded endbox recessed into the suspended ceiling.

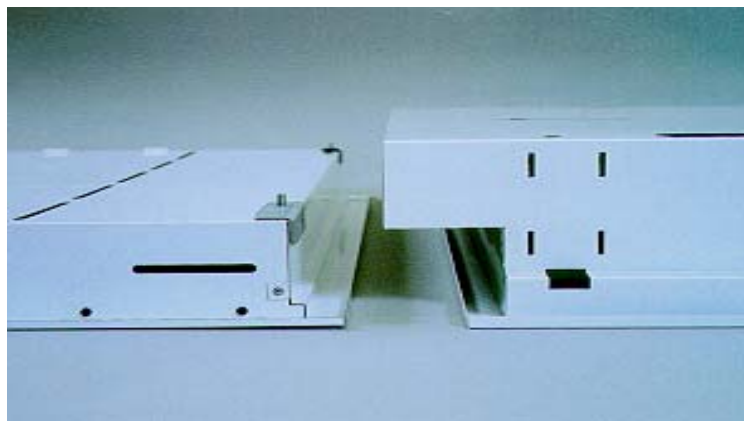

Fig. 13 Recessed Modular T5 Luminaire (left) and T8 Luminaire with Extruded Endbox (Right)

- 5.3 Physically, T5 recessed modular luminaires is much slimmer and can fit exactly into the standard ceiling grid without occupying additional adjacent space. Co-ordination of services at the suspended ceiling is easier where air grills could be mounted directly at the end of the luminaire or luminaires can be run in a continuous row.

- 5.4 Harmonic distortion is a major concern of T5 tube application. As special electronic ballasts with non-linear electronic converters and high frequency oscillator are used for T5 lamp operation, harmonic filtering must be incorporated in the ballast to reduce the current harmonic distortion, especially third harmonic, in order not to affect the power quality of the existing distribution system. Most modern design of electronic ballast nowadays has improved quality in THD and the test result above gave a THD of about 9%.
- 5.5 The current that flows during the first few milliseconds when switching on a luminaire or an entire lighting installation is called the inrush current. For the same lamp wattage the inrush current of electronic ballast is in principle higher than that of conventional ballast. Provided that no more than 10 luminaires with electronic ballasts are controlled by a single 10A lighting switch on a 10A type C MCB lighting circuit, no special provision is required to be made for inrush current at starting.
- 5.6 The power factor of conventional and low loss ballasts can be as low as 0.4 without capacitor for reactive power compensation. Most electronic ballasts nowadays have a displacement power factor approaching unity and a total power above 0.95.
- 5.7 The adoption of T5 tubes in fluorescent luminaires for new projects could have instant effect of reduction in energy and demand charge in electricity bill. It could also meet the requirements for participation in the power companies' Demand Side Management (DSM) programmes for non-residential sector and support the global issue of reducing green house gas emission in electrical power generation.
- 5.8 The 28W T5 luminaire tested had a total circuit power of 30W. The control gear loss can fully comply with the requirement of the Lighting Code (i.e. 10W maximum). The high efficacy of about 100 lm/W for T5 lamp will also enhance the lighting power density for compliance with the Lighting Code.
- 5.9 T5 fluorescent lamps contain less than 30 mg of mercury compared to 40 mg for T12 lamps, so less mercury is disposed of and emitted to the environment during relamping.
- 5.10 From the economic point of view, the material cost of T5 luminaires is about 15% more expensive than the conventional T8 luminaires for new projects. The higher initial cost of the T5 luminaires could easily be compensated via enhanced performance such as high efficacy, high utilisation factor, long lamp life, less heat dissipation, reduced energy and demand charge, etc.
- 5.11 The reliability of electronic ballasts might be the major concern for the project engineers specifying T5 luminaires. From the technical point of view, it is advisable to specify electronic ballasts in accordance with the relevant EMSD particular specifications to ensure quality of the products.
- 5.12 For T5 luminaires operating on electronic ballasts, the electromagnetic compatibility (EMC) problem is basically determined by the characteristics of electronic ballast in combination with the luminaire design. As far as EMC is concerned, the following technical aspects and basic rules have to be considered when incorporating electronic ballasts in luminaires:

- 1) Effective protective earth must be provided for all exposed conductive parts of the metal luminaire.
- 2) Functional earth is required to fulfil certain EMC requirements or to guarantee proper operation of the system.
- 3) Ensure a firm electrical connection between the electronic ballast and the metal luminaire.
- 4) Mains power wiring and lamp wiring inside luminaire must be as short as possible, firmly mounted on spacers and far away from each other to minimise stray capacitance.
- 5) Provide good electrical contact between metal luminaire and reflector and/or louvre. Reflector and louvre serve as a shielding around the lamp.

5.13 Energy Efficiency Office of EMSD has carried out other pilot projects for the application of T5 lamps in government offices including the intelligent lighting control system. The test results will form valuable information for the recommendation of adoption T5 lamps in future government projects.

Reference

- [1] “Code of Practice for Energy Efficiency of Lighting Installations”, 1998 Edition, EMSD.
- [2] “Code of Practice for Energy Efficiency of Electrical Installations”, 1998 Edition, EMSD..
- [3] S.T. Henderson and A.M. Marsden, “Lamps and Lighting” 2nd Edition
- [4] L.T. Lee and K.T. Wu, “Electronic Ballasts for Fluorescent Lamps”, Symposium on tall Building and Construction Technology, Beijing 1999.
- [5] IEC 1000-3-2 “Limits for harmonic current emissions (equipment input current $\leq 16A$)”, 1995.