

LE/02/04

2808 3861

2577 4901

11 October, 1999

All Registered Lift Contractors/Engineers

Dear Sir,

Circular No. 18/99
Code of Practice on the Design and Construction
of Lifts and Escalators (1993 Edition)
Amendment No. 10

Pursuant to section 27G of the Lifts and Escalators (Safety) Ordinance, Cap. 327, the Code of Practice on the Design and Construction of Lifts and Escalators (1993 Edition) (the Code) has been amended by adding new requirements on stairlifts for persons with a disability.

The above changes have been included in the Amendment No. 10 of the Code which is attached for your retention. It shall come into operation on 1 November 1999 and shall be applicable to stairlifts tendered on or after that date.

Please indicate the use (for public or private) and mode of operation (self or attendant) of the stairlift in the test report when submitting the certificate on examination and testing of lift upon completion of the installation (Form 5).

Yours faithfully,

(LAW Yu-wing)
for Director of Electrical & Mechanical Services

c.c. AD/BS
D of Housing (Attn.: TS/2)
D of Building (Attn.: CBS/Legislation)
D of FS (Attn.: Fire Protection Command)
Commissioner for Rehabilitation
(Attn.: Mr. M. C. KAN, Secretary of SCART of Rehabilitation Advisory Committee)
Hong Kong Union of Lift & Escalator Employees

LE/02/25 Pt. II

WKH/GMWC/LYW

**Code of Practice
on the Design and Construction of
Lifts and Escalators
(1993 Edition)**

**AMENDMENT No. 10
Stairlifts**

(Effective as from 1 November 1999 and
applicable to stairlifts tendered on or after that date)

| <u>Item</u> | <u>Clause</u> | <u>Description</u> |
|-------------|-----------------------|--|
| 1 | Section A Clause 1 | <p>Replace “divided into four parts” in the 3rd paragraph by “divided into five parts”.</p> <p>Add the following after the 7th paragraph:-</p> <p>“ Part 5 deals with stairlifts.”</p> |
| 2 | Section B | <p>Add the following publication after o):-</p> <p>“ oA) BS5776 Specification for powered stairlifts”</p> |
| 3 | Section C | <p>Add the following definitions in alphabetical order:-</p> <p>“ Attendant-operated Stairlift</p> <p>A stairlift which is designed for use by the passenger with the assistance of an attendant.</p> <p>Back-up Nut</p> <p>An internally threaded annular component, used in conjunction with a screw and nut drive, so arranged that it does not normally carry the load but is capable of doing so in the event of failure of the threads in the main driving nut.</p> <p>Carriage</p> <p>That whole moving part of a stairlift designed to carry a passenger or a passenger in a wheelchair.</p> <p>Driving Nut</p> <p>An internally threaded annular component that acts in conjunction with a driving screw to produce linear motion of the carriage of a stairlift, i.e. a rotating screw engaging with a fixed nut, or vice versa.</p> |

Driving Screw

An externally threaded driving component that acts in conjunction with a driving nut.

Footrest

A platform or bracket designed for a stairlift so that the passenger is able to stand or to rest his/her feet upon it in complete safety either during movement of the stairlift or when it comes to rest. It is sometimes referred to as foot-supporting platform.

Journey

Movement of a stairlift between any two levels which incorporates one start and one stop.

Rail

Metal formed into a section, or arranged to guide and retain the carriage of a stairlift during its motion in the course of its travel over the stairway.

Ramp

A structure or structural member providing an inclined surface connecting one level with another.

Self-operation

The mode of operation that a stairlift is designed for the passenger to use independently without the help of an attendant.

Sensitive Edge

A safety device attached to any edge to obviate a hazard.

Sensitive Surface

A safety device similar in effect to a sensitive edge but so arranged to protect a whole surface such as the underside of a platform or other large area.

Stairlift

A kind of lift for transporting an ambulant disabled person or person in a wheelchair between two or more levels by means of a guided

carriage/platform moving substantially in the direction of a flight of stairs and travelling in the same path in both upward and downward directions.

Stairway

Any part of a building that provides a route to travel and is formed either by a single flight of stairs or by a combination of two or more flights of stairs and one or more intervening landings. ”

4

Add “ **Section E Part 5: Specification for Stairlifts** ” as follows

Section E

Part 5 : Specification for Stairlifts

Contents

- 1. Design**
 - 1.1 Pattern of Use
 - 1.2 Protection against Hazards
 - 1.3 Design Features
 - 1.4 Maintenance, Repair and Inspection
- 2. Stairway**
 - 2.1 General Provisions
 - 2.2 Angle of Inclination
 - 2.3 Clear Height above Platform
- 3. General Safety Factor**
- 4. Rails**
- 5. Rated Speed and Rated Load**
- 6. Requirements for Drive**
 - 6.1 General Provisions
 - 6.2 Drive Units
 - 6.2.1 General Construction Details
 - 6.2.2 Gearing
 - 6.2.3 Braking
 - 6.2.4 Emergency Operation
 - 6.2.5 Alignment
 - 6.3 Suspension Rope, Drum Drive and Pulleys
 - 6.3.1 Suspension Rope
 - 6.3.2 Winding Drum
 - 6.3.3 Pulleys and Diverter Pulleys

- 6.3.4 Angle of Fleet
- 6.3.5 Protection and Guarding

- 6.4 Rack and Pinion Drive
 - 6.4.1 Driving Pinion
 - 6.4.2 Racks
 - 6.4.3 Guarding

- 6.5 Chain and Chainwheel Drive
 - 6.5.1 Chainwheels
 - 6.5.2 Chains
 - 6.5.3 Protection and Guarding

- 6.6 Screw and Nut Drive
 - 6.6.1 Screw
 - 6.6.2 Nut
 - 6.6.3 Screw/Nut Assembly
 - 6.6.4 Guarding

- 7. Carriage**
 - 7.1 General Provisions
 - 7.1.1 Construction
 - 7.1.2 Load Plate
 - 7.1.3 Nameplate
 - 7.2 Safety
 - 7.2.1 Safety Gear
 - 7.2.2 Overspeed Governor
 - 7.2.3 Rotation Monitor
 - 7.2.4 Back-up Nut
 - 7.3 Chair Carriage
 - 7.4 Standing Platform
 - 7.5 Wheelchair Platform
 - 7.6 Special Adaptations

- 8. Lighting and Emergency Lighting**

- 9. Electrical Equipment**
 - 9.1 General Provisions
 - 9.2 Suppression of Radio and Television Interference
 - 9.3 Control System Design Concept
 - 9.4 Emergency Alarm Devices
 - 9.5 Safety of Electrical Circuits
 - 9.6 Final Limit Safety Switches
 - 9.7 Construction
 - 9.8 Residual Current Devices
 - 9.9 Trailing Cables
- 10. Battery Powered Operation**
- 11. Self-operation**
- 12. Attendant-operated Stairlift**
- 13. User Guide and Operation Manual**

1. Design

1.1 Pattern of Use

The design of the stairlift shall take account of the use to which it will be subjected and the maximum number of journeys per hour and per day. Motor and gearbox thermal time ratings shall be not less than 25%. In addition, the gearbox wear rating shall ensure a minimum life of 100,000 starts and 2,500 hours at full load.

The design shall also involve the determination of any limitations of the passenger's ability to manoeuvre with respect to the position relative to the landing floors, and manoeuvring space on the landings.

1.2 Protection against Hazards

Protection shall be incorporated in the stairlift to minimize all of the following hazards:

- (a) shearing, crushing, trapping or abrading;
- (b) falling;
- (c) physical shock;
- (d) electric shock;
- (e) fire, attributable to use of the stairlift.

1.3 Design Features

1.3.1 All components shall be designed to take account of all static and dynamic loads and forces.

Components shall be of sound mechanical and electrical construction using materials that are free from obvious defect. The dimensions specified in this standard shall be maintained despite wear. The transmission of noise and vibration to any surrounding walls and other supporting structures shall be minimized.

1.3.2 Plastics components shall be of flame retardant, self-extinguishing grade material.

The stairlift shall not be made of materials likely to become dangerous through flammability or through the nature and quantity of gas and fumes they may generate if ignited.

1.4 Maintenance, Repair and Inspection

The stairlift shall be designed, constructed and installed in such a manner that any maintenance, repair, major alteration, replacement, examination, testing and inspection can be carried out safely and without difficulty.

2. Stairway

2.1 General Provisions

2.1.1 The following shall not be permitted along the stairway where a stairlift is installed:

- (a) Doors, shutters and windows (or their furniture) that present a hazard when open;
- (b) Pipes conveying steam, gas or liquid which, if discharged into the stairway, would endanger life or health.

2.1.2 The positions of landings shall be at such locations that passengers can get on and off the stairlift safely and easily.

2.1.3 The stairlift shall be accessible along the stairway at all times and in all circumstances.

2.2 Angle of Inclination

No stairlift shall be installed to operate on an inclination greater than 45° as measured on the mean.

2.3 Clear Height above Platform

The clear height above the platform of the stairlift (the footrest in case of chair carriage stairlift (see Clause 7.3)) shall be not less than 2 m along its whole journey.

3. General Safety Factor

Unless stated otherwise, the safety factor for all parts of the equipment shall be not less than 3.

4. Rails

4.1 Rails shall be used to retain and guide the carriage, which supports the chair, platform or other purpose-made adaptation for the passenger throughout its travel, whether the travel is horizontal or inclined, straight or curved. Any deflection of the rails or their fixings shall be limited so that no discomfort or danger to the passenger results. They shall have a safety factor of not less than 5 based on the rated load.

4.2 The rails, their attachments and joints shall withstand, without permanent deformation, the maximum forces likely to be imposed during normal usage of the stairlift and also the additional forces imposed by operation of the safety gear.

- 4.3 The rails shall be fitted with end stops.
- 4.4 The supporting rails shall be securely fixed to the stairs or stairway wall and the fixings shall withstand any of the forces specified in Clause 4.2.
- 4.5 Folding rail sections shall not obstruct the stairway or landing when folded.
- 4.6 Manually operated folding rail sections shall be counter-balanced.
- 4.7 A safety switch shall be fitted to prevent operation of the stairlift except when the folded rail section is in the operating position. The switch shall be actuated as soon as the rail joint is opened and shall remain so when the folding rail section is other than in the operating position.
- 4.8 A warning label, in English and Chinese in letters and characters of height not less than 10 mm as shown below, shall be fitted adjacent to the hinged section of rail.

WARNING
KEEP HANDS CLEAR OF HINGE
AT ALL TIMES

警告
不論何時
切勿觸及鉸鏈

- 4.9 If the folding rail is operated by a motorized drive, the control circuits shall be energized by a voltage of less than 55 V and the motor and control circuits shall be electrically protected. The control system shall operate from constant pressure push buttons, but motorized drives shall be capable of manual operation. The drive to the hinged mechanism shall be protected to prevent damage to the mechanism should it encounter an obstruction (e.g. protection by a slipping clutch, overload detector or motor torque limiter).

5. Rated Speed and Rated Load

- 5.1 The rated speed of the stairlift shall not exceed 0.15 m/s when measured at the reference points shown in figure 1, at any point of travel (including travel around a curved section of rail).
- 5.2 For chair carriage (see Clause 7.3) or standing platform (see Clause 7.4) stairlift, which is designed for a capacity of one person, the rated load shall be not less than 115 kg.

For wheelchair platform (see Clause 7.5) stairlift, which is designed for a capacity of one person in a wheelchair, the minimum rated load shall be as follows:

| | |
|------------|-------------|
| Public use | Private use |
|------------|-------------|

| | | | |
|--------------------|-------------------------|---|---|
| (see Clause 7.5.1) | | | |
| 225 kg | Power-driven wheelchair | Manual wheelchair | |
| | 225 kg | Net platform area > 0.84 m ² | Net platform area ≤ 0.84 m ² |
| | | 205 kg | 150 kg |

6. Requirements for Drive

6.1 General Provisions

The selected drive shall be in accordance with Clauses 6.2 to 6.6 as appropriate, or shall provide an equivalent level of safety.

6.2 Drive Units

6.2.1 General Construction Details

All types of drive shall be capable of being powered in both directions.

6.2.2 Gearing

The safety factor used in the design of geared drive units shall be based on the static loads imposed by the fully laden carriage on the driving mechanism and shall be not less than 6.

All shouldered shafts shall be provided with fillets.

Unless forming an integral part of its shaft or driving unit every sheave, rope drum, spur gear, worm and worm-wheel, winding drum, pinion, driving chainwheel or brake drum shall be fixed to its shaft or other driving unit by one of the following methods:

- (a) sunk keys;
- (b) splines;
- (c) any other means that provides an equivalent level of safety.

Worm gearing having cast iron teeth shall not be used in the driving unit. Friction gearing mechanisms (i.e. drives depending on friction between the surfaces of adjacent pulleys or friction clutches) shall not be used for connecting the main driving unit to the drum, pinion, chainwheel, nut or other final output component. All gearing shall be fully guarded by imperforate material. Gearing on curved rail stairlifts shall be guarded as far as practicable.

If chain or toothed belt drives are employed, a device incorporating a safety switch shall be provided to break the power supply to the motor and brake control

circuits if either the chain or the toothed belt breaks or slackens by a predetermined amount.

6.2.3 Braking

The drive unit shall be provided with a brake capable of bringing the carriage smoothly to rest within a distance of 20 mm and holding it firmly in position under maximum load conditions. This brake shall be applied mechanically and held off electrically. The brake shall operate through positive gearing to stop the final output shaft.

Brake linings shall be of asbestos-free material that do not support combustion and shall be so secured to the brake shoes that normal wear will not weaken their fastenings.

When springs are used to apply the brake shoes, such springs shall be in compression and supported.

The brake shall not be released in normal operation unless the power supply is simultaneously applied to the stairlift motor and the brake.

No earth fault or residual magnetism shall prevent the brake from being applied when the power supply to the drive motor is interrupted.

6.2.4 Emergency Operation

One of the following means shall be provided for moving the carriage in an emergency:

- (a) a smooth spokeless wheel for manual operation, any cover of which is to be removable without tools; or
- (b) a standby power system for motorized operation. In this case, a safety switch shall be provided to disable the normal controls when the standby power system is engaged.

Where the resisting torque of the brake is too great to be overcome by emergency hand winding, means shall be provided of releasing the brake to ensure that the lowering is under control. Free fall conditions shall not be possible under any circumstances. A toggle, or other device, which could be left in a locked position, shall not be used to hold off the brake.

Instructions shall be provided stating the following:

- (a) that emergency operation is to be undertaken only in accordance with the correct procedure;
- (b) the correct procedure in step by step detail;

- (c) that the electrical supply is to be switched off and the carriage is to be under constant surveillance whilst in emergency operation.

A direction label, with words 'UP 上' and 'DOWN 落' in English and Chinese and the corresponding arrows, shall be fitted in a prominent position on the drive unit. The height of letters and characters used on the label shall be not less than 10 mm.

6.2.5 Alignment

The gearing, brake and motor shall be mounted and assembled so that proper alignment is maintained under all normal working conditions.

6.3 Suspension Rope, Drum Drive and Pulleys

6.3.1 Suspension Rope

All suspension ropes shall conform to BS 302 : Part 1 : 1987 and Part 2 : 1987 or Part 4 : 1987 as appropriate, or other relevant international standards. The safety factor of the ropes shall be not less than 12. The safety factor shall be the ratio between the minimum breaking load of any rope and the continuous load imposed in raising the fully loaded carriage. Test certificates for the ropes shall be provided.

The ends of the ropes shall be fixed to the carriage, counterweight or suspension points by such methods as metal or resin-filled sockets, self-tightening wedge-type sockets, heart thimbles with at least three rope grips or hand-spliced ferrule-secured eyes. The strength of the rope anchorages shall be not less than 80% of the strength of the ropes.

6.3.2 Winding Drum

Winding drums shall be of aluminium alloy, cast iron or steel. The grooves shall be smoothly finished with rounded edges. Plain winding drums shall not be used. The bottom of the rope groove shall be a circular arc over an angle of not less than 120°. Radius of the grooving shall be not less than 5% in nominal radius of the suspension rope. The grooves shall be pitched so that there is clearance between adjacent rope turns on the drum and also between any part of the rope leading onto the drum and on the adjacent turn. Drum grooves shall have a depth not less than one third of the nominal diameter of the rope.

The diameter of the drum shall be not less than 21 times the nominal rope diameter. There shall be not less than 1.5 dead turns of rope on the drum when the carriage is at its lowest point.

The drum flanges shall project by not less than 2 rope diameters beyond the outer layer of rope when the drum is full.

Winding drums shall be fixed to the driving unit shaft in accordance with Clause 6.2.2.

6.3.3 Pulleys and Diverter Pulleys

Pulleys shall be of cast iron or steel. The grooves shall be smoothly finished with rounded edges. The bottom of the groove shall have the same profile as for drum grooving but the depth of the groove shall be not less than 1.5 times the nominal diameter of the rope. The angle of flare of the sides of pulley grooves shall be approximately 52°.

The diameter of pulleys, measured at the bottom of the groove, shall be not less than 21 times the nominal rope diameter.

6.3.4 Angle of Fleet

The maximum angle of fleet between the rope and a plane perpendicular to the axis of the pulley, as illustrated in figure 2, shall not exceed 2°.

6.3.5 Protection and Guarding

A device incorporating a safety switch shall be provided to break the power supply to the motor and brake control circuits if the rope breaks or slackens by a predetermined amount.

Drums, and if necessary pulleys, shall be guarded to ensure that the rope is retained in the grooving under all circumstances and to ensure that trapping between rope and drum or pulley cannot occur. Ropes shall also be guarded if their alignment is a potential hazard.

6.4 Rack and Pinion Drive

This type of positive drive is particularly applicable to stairlifts that are to negotiate curves and/or changes in inclination.

For full advantage to be taken of the safety potential of this type of drive, particular care should be taken in the design of the gearing from the motor to the driving pinion and, in particular, to the strength of the output shaft.

6.4.1 Driving Pinion

The driving pinion shall be machined from an alloy steel with a high impact strength. It shall be designed to resist wear and shall have a safety factor of not less than 6. The number of gear teeth on the pinion shall be sufficient to prevent undercutting of the teeth.

The pinion shall be fixed to the output shaft in accordance with Clause 6.2.2.

6.4.2 Racks

The racks shall be made from materials having properties matching those of the pinion in wear and impact strength, and shall have a safety factor of not less than 6.

The racks shall be securely attached to the rails particularly at their ends, and means shall be provided to maintain the rack and pinion constantly in accurate mesh under all conditions of load. Any joints in the rack shall be accurately aligned to avoid faulty meshing or damage to teeth.

6.4.3 Guarding

Guards shall be fitted to prevent trapping hazards between the rack and pinion, and any other part (see Clauses 1.2, 6.3.5 & 6.5.3).

On curved rail stairlifts, a warning label, in English and Chinese in letters and characters of height not less than 10 mm as shown below, shall be fitted to the carriage adjacent to the hazard.

WARNING
MOVING PARTS

警告
移動部件

6.5 Chain and Chainwheel Drive

6.5.1 Chainwheels

All driving chainwheels shall be made from steel and have a minimum of 16 machine-cut teeth. Driving chainwheels shall be fixed to the drive shaft in accordance with Clause 6.2.2. A minimum of eight teeth shall be in engagement with the chain.

6.5.2 Chains

All chains shall conform to the requirements of BS 228 : 1994, or ISO 606, or other relevant international standards. The safety factor of the chain(s) shall be not less than 10. The safety factor shall be the ratio between the minimum breaking load of any chain and the continuous load imposed in raising the fully loaded carriage. The minimum breaking load of the chain shall be not less than 8 kN. Test certificates for the chain(s) shall be provided.

Connecting links shall have a strength not less than that of the chain.

6.5.3 Protection and Guarding

Means shall be provided to prevent jamming due to misfeeding or slackening of the chains and to prevent the chains from leaving the chainwheels or riding over the teeth of the chainwheels.

A device incorporating a safety switch shall be provided to break the power supply to the motor and brake control circuits if the chain breaks or slackens by a predetermined amount.

Guards shall be fitted to prevent trapping hazards between chainwheel and chain or chain and any other part of the drive mechanism.

Reference can be made to examples of guards given in BS 5304, or other relevant international standards.

6.6 Screw and Nut Drive

6.6.1 Screw

The screw shall be machined from steel. It shall be designed to resist wear and shall have a safety factor of not less than 6.

6.6.2 Nut

The nut shall be made from a material compatible with the screw with respect to wear and impact strength, and shall have a safety factor of not less than 6.

6.6.3 Screw/Nut Assembly

The drive to the rotating component shall be directly controlled by a brake. The rotating component shall be restrained against axial or radial movement by means of anti-friction bearings.

6.6.4 Guarding

Means shall be provided to guard all moving parts and to prevent the fouling of the screw threads with dirt or other foreign matter.

7. Carriage

Various forms of carriage can be used for conveying the intended passenger depending upon the individual needs. The broad classifications are as follows:

- (a) chair carriage (Clause 7.3);
- (b) standing platform (Clause 7.4);
- (c) wheelchair platform (Clause 7.5).

7.1 General Provisions

7.1.1 Construction

The carriage shall be of metal construction and consist of a mobile chassis, which is retained, supported and guided by one or more rails, upon which a chair, platform or other purpose-made adaptation to carry the passenger is supported and securely attached.

The construction of the entire carriage shall be designed to form a robust and safe conveyance at its safe working load. It shall have a safety factor of not less than 5 based on the rated load.

Any part or edge of the carriage that is intended to be used as a supporting hand hold shall have clearance from any part of the fixed installation to prevent hands from being trapped during the travel of the carriage.

The strength of attachments for suspension ropes or chains to the carriage shall be greater than 80% of the strength of the rope or the chain.

7.1.2 Load Plate

A load plate shall be securely mounted in a prominent and visible position, either on the carriage or at each landing adjacent to the stairlift. The plate shall carry a legend in English and Chinese and similar in content and layout to that shown below:

WARNING
THE SAFE WORKING LOAD IS ONE PERSON ONLY AT
A MAXIMUM TOTAL WEIGHT OF _____

警告
安全操作負載只限一人
最高總載重為_____

The maximum weight displayed on the load plate shall be the rated load.

The height of letters and characters used on the load plate shall be not less than 10 mm.

7.1.3 Nameplate

A nameplate or plates conforming to BS 3456 : Part 101 : 1987, or IEC 335 : Part 1, or other relevant international standards which includes the manufacturer's name, the brand/model and serial number of the machine shall be securely attached in a prominent position on the carriage.

7.2 Safety

7.2.1 Safety Gear

With the exception of screw and nut driven stairlifts the stairlift carriage shall be fitted with a safety gear, operating in the downward direction only, capable of preventing uncontrolled descent of the carriage in the event of failure of the drive unit.

Release of the safety gear shall be possible only by raising the carriage up the rail.

The safety gear shall be designed to grip the rail securely and the gripping method shall be progressive such as that provided by a cam profile or a wedge mechanism.

The application of the safety gear shall not cause the carriage to change inclination by more than 10°.

The power supply to the motor and brake control circuits shall be disconnected by a safety switch on the safety gear before, or at the time, the safety gear is actuated.

When the safety gear is applied, no decrease in the tension of any rope or chain or other mechanism used for applying the safety gear, or motion of the carriage in the downward direction, shall release the safety gear.

Any shaft, jaw, wedge or support that forms part of the safety gear and which is stressed during its operation shall be made of steel or other ductile material.

7.2.2 Overspeed Governor

In the event of an overspeed condition, the safety gear shall be actuated by an overspeed governor when the descending carriage attains a speed of at least 115% of rated speed, but not more than 0.3 m/s.

If the overspeed governor derives its drive from a main suspension chain or rope, the safety gear shall also be operated by a mechanism actuated by breaking, or slackening of, the main suspension chain or rope.

7.2.3 Rotation Monitor

If the overspeed governor is friction driven as opposed to positively driven from a rack or chain, the control system shall include circuitry to monitor rotation of the overspeed governor drive during travel. If rotation ceases, the power supply to the driving motor and brake shall be interrupted within 10 s. Correct functioning of the reset shall be checked at least once during normal travel. Passenger instructions shall give prominent advice that intermittent operation may indicate a malfunction of the overspeed governor and that specialist attention is required before further use.

The rotation monitor may be reset by releasing the directional control button.

7.2.4 Back-up Nut

Screw and nut drives shall conform to Clause 6.6 and shall be provided with a back-up nut fitted with an electrical safety contact. The degree of safety provided by a back-up nut in a screw and nut drive shall be not less than that specified in Clause 6.6.2.

7.3 Chair Carriage

7.3.1 The chair on the carriage shall consist of a seat, backrest, armrest(s) or hand grip(s) and a footrest (or foot-supporting platform), arranged to provide a safe support for the passenger. The top of the backrest shall be not less than 300 mm above the surface of the seat.

If it is necessary to conserve space, the seat, armrest(s) (or hand grip(s)) and footrest or foot-supporting platform, as appropriate, shall be arranged to fold up when not in use.

If it is necessary to provide easier or safer access, the chair shall be capable of movement, e.g. rotation.

Whichever of these arrangements is adopted, the design shall be such as to prevent injury whilst these movements are carried out.

When the chair is stationary at its normal position at the lower and upper landings (and any intermediate landing), the height of the surface of the footrest (or foot-supporting platform) above the floor shall not exceed 200 mm.

A safety belt or other safety restraint shall be fitted to the chair to restrain the passenger during travel.

7.3.2 Stairlifts with sliding or rotating seats shall have a safety contact to prevent operation of the chair unless it is in its fully operational position.

A mechanical lock, capable of easy release, shall be provided to secure sliding or rotating seats at the extremes of their travel.

7.3.3 Sensitive edges or sensitive surfaces shall be fitted in areas where there are potential shearing, crushing, trapping or abrading hazards. Their activation shall disconnect the power supply to the motor in the direction of travel and, except in the specific case of protection against trapping between two carriage mounted components where the hazard arises and the operation of the sensitive edge or surface is effective in both directions of travel, shall allow operation of the carriage in the opposite direction to clear the obstacle (see Clause 9.5.9). The carriage shall come to rest within 25 mm of the point of first contact with the obstacle. The follow-through of the sensitive edge or surface shall be sufficient to prevent injury of the passenger.

The following are examples of potentially dangerous places that require such protection:

- (a) any open space about, or within, the rails where parts of the carriage may pass;
- (b) any fixed abutments, e.g. at the rail terminations;
- (c) all edges and the underside of the footrest (or foot-supporting platform);
- (d) any other part of the carriage that passes over the edges of stairs, rail fixing brackets, etc.

Wherever practicable, any other part of the carriage that may come into forcible contact with the passenger, or other persons, shall be padded or protected.

7.3.4 The average force required to operate the sensitive edges shall not exceed 30 N when measured at each end and the mid-point of the sensitive edges.

The average force required to operate the sensitive surfaces shall not exceed the following:

- (a) 35 N for surfaces with an area equal to or less than 0.15 m²;
- (b) 50 N for surfaces with an area greater than 0.15 m².

The force shall be measured at two diagonally opposite corners and at the centre point of a sensitive surface.

7.4 Standing Platform

7.4.1 The standing platform shall be at least 325 mm in depth and 350 mm in length. The platform shall be provided with hand grips and supports for the passenger when travelling or when stepping on or off the platform.

The surface of the platform shall be covered with slip-resistant material.

If it is necessary to conserve space, the platform, frame and hand grips, as appropriate, shall be arranged to fold away when not in use.

When the platform is stationary at its normal position at any landing, the height of the platform surface above the floor shall not exceed 200 mm.

7.4.2 Standing platforms shall have safety features which conform to Clause 7.3.3.

7.5 Wheelchair Platform

7.5.1 The surface of the wheelchair platform shall be covered with slip-resistant material.

Means shall be provided to ensure that the wheelchair is correctly positioned and restrained within the area of the wheelchair platform during travel.

If the wheelchair platform is designed for public use (see Clause 5.2), the platform dimensions shall be at least 760 mm in depth and 1,220 mm in length.

The inside net platform area shall not exceed 1.11 m².

The side of the wheelchair platform adjacent to the wall shall be solid, and shall extend to a minimum height of 1,100 mm above the platform surface.

The solid-faced side may be fitted with controls and hand grips or hand rails for stability of the passenger.

7.5.2 Where ramps are fitted to platform access edges a safety switch shall be incorporated to ensure that the ramps are in the raised position before movement of the platform can be initiated. The design of these devices shall ensure that at the upper level of travel only the ramps, on the edge or edges nearest to the landing at which the platform is stationary, can be lowered.

When the wheelchair platform is stationary at its bottom landing, either a shallow pit shall be provided to avoid any step, or ramps shall be used.

When the wheelchair platform is stationary at the upper landing, bridging flaps shall be provided to bridge any gap between the platform and landing that would prevent free movement of the wheelchair.

The ramps and/or flaps shall be radiused, and shall not exceed a thickness of 15 mm. The ramp shall have an inclination not greater than the following:

- (a) 1:4 on a vertical rise of up to 50 mm;
- (b) 1:6 on a vertical rise of up to 75 mm;
- (c) 1:8 on a vertical rise of up to 100 mm;
- (d) 1:12 on a vertical rise of over 100 mm.

7.5.3 Wheelchair platforms shall have safety features which conform to Clause 7.3.3.

7.6 Special Adaptations

Special adaptations or combinations of chair lifts, standing platforms, or wheelchair platforms shall conform to Clauses 7.3 to 7.5 as applicable.

8 Lighting and Emergency Lighting

8.1 The stairlift and control panel at each landing (upper, intermediate and lower) shall be provided with electrical lighting that is permanently illuminated ensuring a light intensity of at least 50 lux on all control switches and on the surface of the platform (the footrest in case of chair carriage stairlift (see Clause 7.3)).

8.2 The stairlift and control panel at each landing (upper, intermediate and lower) shall also be provided with emergency lighting of at least a 1W lamp fed by an automatically rechargeable emergency supply which is capable of feeding it alone for at least 2 hours in case of an interruption of the normal lighting supply. This emergency lighting shall come on automatically upon failure of the normal lighting supply. The charger shall be capable of fully re-charging the batteries in not more than 12 hours.

9. Electrical Equipment

9.1 General Provisions

The electrical specification and construction of the stairlift shall conform to BS 3456 : Part 101 : 1987, or IEC 335 : Part 1 and BS 3456 : Part 201 : 1990, or IEC 335 : Part 1 : 1983 as applicable, or other relevant international standards.

9.2 Suppression of Radio and Television Interference

The design of the electric motor, contact devices and control devices shall conform to BS EN 55014 : 1993, or other relevant international standards. Suppression components shall not be used in any part of the circuit where their failure might cause an unsafe condition.

9.3 Control System Design Concept

9.3.1 All control circuits shall be designed to fail safe.

Although wired control circuits throughout would produce an installation having a very high degree of safety it may be necessary to resort to the use of remote control devices, specially adapted switches and sensors.

A lockable on/off switch shall be used to restrict the use of the stairlift to the intended passenger and prevent the possibility of accidents caused by children playing with the stairlift.

9.3.2 Switches fitted to the carriage and elsewhere to control the movement of the stairlift shall be operated by constant pressure e.g. push buttons or spring-biased toggle devices that positively return to the off position when released.

All up and down control switches shall be electrically interlocked. Release of the constant pressure switch shall cause immediate removal of the power supply to the brake and driving motor.

A carriage holding switch shall be used to prevent the carriage being called by another person whilst the passenger is getting on or off.

A bi-stable isolating safety switch shall be fitted on the carriage which, when operated, directly activates the safety circuit. This switch is also intended as a carriage holding switch.

Carriage stopping devices (and landing stopping devices where fitted) shall be clearly visible and accessible to the passenger, easy to operate and protected by position or design against inadvertent operation.

The stopping device shall be of the “push-to-stop, pull-to-run” type. There shall be the words ‘STOP 停止’ in English and Chinese on or near the stopping device so placed that there can be no risk of error as to the stop position.

The stairlift shall have a safety switch to prevent its operation unless it is in fully folded or unfolded position.

- 9.3.3** Control limit switches operated by the movement of the carriage shall be provided to stop it automatically at the normal floors/storeys served.

If springs are used to actuate switches, contactors or relays to break the circuit to stop the stairlift at the terminal landing, they shall be of the restrained compression type.

9.4 Emergency Alarm Devices

- 9.4.1** Call bell/emergency alarm push button together with a buzzer (or an alarm bell) shall be provided at each landing (upper, intermediate and lower) and be connected to the building management office or the caretaker’s office. The push button shall be located at height not less than 900 mm and not more than 1,200 mm above finished floor level and in such a way that the passenger can operate it easily and safely.

For stairlift which is designed for self-operation (see Clause 11), an call bell/emergency alarm push button together with a buzzer (or an alarm bell) shall also be provided on the carriage and connected to the building management office or the caretaker’s office. The push button shall be located at height and in such a way as mentioned above.

The building management office or the caretaker’s office shall be equipped with buzzer (or alarm bell) and indication light(s) (one for each stairlift) connected to the landings and, if self-operated stairlift, the carriage(s).

- 9.4.2** The buzzer (or alarm bell) shall ring and the indication light shall be lit if the call bell/emergency alarm push button is pressed. The indication light shall remain on until it is manually reset by activation of a reset switch inside the building

management office or the caretaker's office.

- 9.4.3** All the devices under this Clause 9.4 shall be backed up by the emergency supply called for in Clause 8.2 or by an equivalent supply.
- 9.4.4** Appropriate notices or labels (in English and Chinese) shall be displayed next to all the devices provided under this Clause 9.4, indicating the function and/or operation of them.
- 9.4.5** The sound generated by the buzzer (or alarm bell) shall be distinguishable from that of fire alarm.
- 9.4.6** If there is no building management office or caretaker's office in the building, the buzzer (or alarm bell), indication light(s) and reset switch shall be placed immediately outside the main entrance of the building at the street.

9.5 Safety of Electrical Circuits

- 9.5.1** The motor circuit shall be protected by a cut-out that operates within 10 s of the motor stalling.
- 9.5.2** The control circuit voltage shall not exceed 55 V. Control circuits directly derived from a mains supply shall be fed from the secondary winding of an isolating transformer conforming to BS 3535 : Part 1 : 1990 and Part 2 : 1990, or EN 60742, or other relevant international standards.

One pole of the control circuit voltage supply shall be earthed and the other pole shall be fused as illustrated in figure 3a for an a.c. supply, or figures 3b, 3c and 3d, for a d.c. supply.

Earthing and fusing requirements for battery powered stairlifts are in figures 4a and 4b.

- 9.5.3** Contactors, relays or electronic devices for reversing direction of travel shall be electrically interlocked.
- 9.5.4** All contacts on any contactor used for direct control of the supply to the main driving motor shall be linked so that all contacts on a contactor open or close together such that in the event of one contact becoming welded, all contacts are retained in the same position and no contact occurs in the opposite sense.
- 9.5.5** The main motor and brake control circuit shall have at least two independently operated contacts or one contact and one electronic device in series. The circuit shall be designed such that the failure of one contact or device prevents operation of the stairlift not later than the next change of direction.
- 9.5.6** The control system shall not depend upon the closing or maintenance of an electrical control circuit for the isolation of the power supply to stop the drive

motor and apply the brake.

- 9.5.7** Provision shall be made for a delay of 3 s minimum between the stopping of the stairlift and its being restarted in either direction. In addition there shall be a minimum 0.5 s delay between activation of any directional control device and the movement of the stairlift.
- 9.5.8** Control circuits shall be so arranged that an earth fault or open circuit, or the discharge or failure of a capacitor, does not give rise to an unsafe condition.
- 9.5.9** Operation of a sensitive edge or surface by an obstruction shall cause the supply to the motor to be interrupted and prevent it from producing any movement of the carriage towards the obstruction. It shall be possible, after the delay specified in Clause 9.5.7, to drive the carriage away from the obstruction (see Clause 7.3.3).

Operation of slack rope or chain safety switches (see Clauses 6.2.2, 6.3.5, 6.5.3), safety gear safety switches (see Clause 7.2.1), or final limit safety switches (see Clause 9.6) shall cause the power supply to the motor and brake to be interrupted preventing any further movement of the carriage (in either direction) and necessitating the resetting of the safety device and reinstating of the supply to the controller. It shall not be possible to restart the machine until the carriage has been correctly repositioned manually and the final limit safety switch reset.

- 9.5.10** The creepage and clearance distance between all safety circuits/switches and adjacent circuits shall conform to the table contained within clause 210 of BS 3456 : Part 201 : 1990, or IEC 335 : Part 1 : 1983, or other relevant international standards.

9.6 Final Limit Safety Switches

To isolate the motor, the brake and controller from the power supply in the event of overtravel of the carriage beyond its normal stopping position, a final limit safety switch shall be provided at each end of the travel except that the lower final limit safety switch need not be fitted in the case of those drives where a slack rope or chain switch comes into operation and stops the carriage within 40 mm of the normal limit stop.

The design of these switches shall withstand possible abuse from adverse domestic cleaning activities.

9.7 Construction

- 9.7.1** Controllers shall be enclosed so as to prevent inadvertent contact with live terminals. Covers shall be retained by captive devices requiring the use of tools for their removal (see also Clause 9.7.2).
- 9.7.2** Enclosures containing live parts, including any access cover forming part of that enclosure, shall withstand a force of 300 N, being evenly distributed over an area

of 2,500 mm² in round or square section, applied at any point perpendicular to the surface.

- 9.7.3** Materials used in the construction of the control circuit shall not support combustion.
- 9.7.4** All terminals throughout the system shall be marked and conductors shall be terminated by soldering, clamping or crimping in such a way that the conductors and the insulation are not damaged.
- 9.7.5** The insulation of the controller wiring shall be of flame-retardant type.
- 9.7.6** All earth continuity conductors shall be copper except when slip rings or tracks and carbon brushes are used. At least one slip ring or track and carbon brush and trailing cable way shall be dedicated to the earth path (see Clause 9.8).
- 9.7.7** Wiring and components at a potential exceeding 24 V shall not be accessible to touch without first obtaining access by use of a tool.
- 9.7.8** Any nut or screw used for clamping a conductor shall not be used for clamping any other component.
- 9.7.9** Mains input terminals shall be conveniently accessible within the equipment and shall be marked to indicate their polarity, i.e. L for live and N for neutral. The main earth terminal shall be located conveniently near the main input and identified by E.
- 9.7.10** Earthing terminals shall maintain electrical continuity, shall be of the stud type and shall be not smaller than M5. They shall not be used for securing any component nor shall it be possible to loosen the connection without the use of a tool. All earth conductors shall be terminated with crimped or soldered terminations.
- 9.7.11** All exposed metal work which could possibly become electrically charged shall be earth bonded.

9.8 Residual Current Devices

A trailing cable carrying a voltage greater than 55 V above earth shall be protected by the use of a residual current device (RCD) conforming to either BS 4293 : 1983 or BS 7071 : 1992 or BS 7288 : 1990, as appropriate, or other relevant international standards. The maximum rated tripping current shall be 30 mA. The maximum trip time at rated tripping current shall be 200 ms. The maximum trip time at 5 times the rated tripping current shall be 40 ms. Where fitted, this RCD shall protect all parts of the installation that are at 240V. The testing of this RCD shall not cause any spurious tripping of any other RCD fitted to the mains supply circuit.

9.9 Trailing Cables

Trailing cables need not be used in the case of battery powered operation (see Clause 10)

The trailing electrical power and control cables shall be securely clamped at each end to prevent them from pulling from their terminations. Provision shall be made to protect each cable from abrasion.

Flat cables shall conform to BS EN 50214 : 1998, or other relevant international standards. Round cables shall conform to table 16 of BS 6500 : 1994 for 300/500 requirements, or IEC 245, or other relevant international standards.

Cables with 6 and 7 cores shall have sheath and insulation thicknesses conforming to table 16 of BS 6500 : 1994, or IEC 245, or other relevant international standards.

Round cables shall be formed around a central core which shall not be used as a conductor, either current carrying or earth. All conductors shall be of equal cross-sectional area.

The nominal cross-sectional area of all conductors in a trailing cable shall be not less than 0.75 mm².

Where a trailing cable, winding drum or linear bus bar device incorporating slip rings or tracks and carbon brushes is used, the current carrying capacity of the carbon brushes and slip rings or tracks shall be not less than that of the current carrying conductor to the carriage.

10. Battery Powered Operation

10.1 Battery powered stairlift designed for public use shall be of the type that can be automatically rechargeable.

10.2 Batteries shall not leak when tilted and battery enclosures shall be ventilated. The battery charger shall not damage or overcharge the battery, even after long periods on charge.

The design of the battery shall be such that it does not emit a dangerous level of fumes during normal operation or during charging.

10.3 A fuse shall be fitted in line with the battery supply which shall only be accessible by the use of an appropriate tool(s). This fuse shall isolate the battery supply with 0.5 s of the supply being short circuited and within 5 s of twice average peak current being drawn.

10.4 The charging arrangement for the batteries shall typically be as shown in figure 4a for a.c. charging and figure 4b for d.c. charging. The maximum voltage potential

when measured with respect to earth shall be 55 V for protected charge contacts and 24 V for exposed charge contacts.

Charge contacts are deemed to be exposed when they are accessible without the use of tools, and protected where it is not possible to touch the contacts without the use of tools.

Battery charging should be carried out at points where the stairlift is expected to be stationary between journeys. Usually this is at each end of the rail.

- 10.5** Battery terminals shall be physically protected against short circuiting.
- 10.6** Batteries shall be securely fitted in the carriage structure.
- 10.7** Any voltage potential within the carriage shall not exceed 55 V.
- 10.8** Batteries shall have a life of at least three years in normal use.
- 10.9** The battery supply shall be capable of being isolated by use of a switch or plug fitted to the carriage which shall be accessible and operable without the use of a tool.
- 10.10** The charging rate of the battery shall be such that the charging energy supplied over a period of 24 hours on continuous charge is at least equal to the energy drawn from the battery by 15 upward and 15 downward journeys of the stairlift.
- 10.11** The battery capacity shall be such that, when it is fully charged, the stairlift shall be capable of completing at least 10 upward and 10 downward journeys under full load without charging.
- 10.12** If the stairlift is brought to rest out of the reach of the charge contacts, this shall be indicated to the passenger.
- 10.13** The carriage chassis shall be grounded as shown in figure 4.

11. Self-operation

- 11.1** The operation of the stairlift from each landing (upper, intermediate and lower) and from the carriage shall be controlled by a common key.

A key-operated switch shall be provided at each landing and on the carriage which will allow the control switches to become effective only when the key is in the “on” position. The key shall be removable only from the “off” position.

- 11.2** The stairlift shall be in folded state when it is being called or sent from one landing to another.

The safety features which conform to Clause 7.3.3 shall remain valid when the

stairlift is being called or sent in folded state.

- 11.3** Folding and unfolding of the stairlift shall be power-operated and controlled by switches (see Clause 11.4).

When the stairlift is unfolded, there shall be a clear width of at least 500 mm on the stairway along the whole journey to allow passage of other users. This width is measured from the side edge of the stairlift to the finished surface of the wall or the projection of the outer edge of handrail or any protruding objects, whichever is the minimum.

- 11.4** Stopping device and control switches for calling, sending, folding and unfolding the stairlift shall be provided at each landing (upper, intermediate and lower) and conform to Clause 9.3.2. They shall be located at height and in such a way as mentioned in Clause 9.4.1.

- 11.5** Stopping device and control switches for upward and downward movement of the stairlift shall be provided on the carriage and conform to Clause 9.3.2. They shall be located at height and in such a way as mentioned in Clause 9.4.1.

In the case of chair carriage stairlift, the above stopping device and control switches shall be located on the armrest(s) for easy and safe operation.

- 11.6** Appropriate notices or labels (in English and Chinese) shall be displayed next to all the devices mentioned under this Clause 11, indicating the function and/or operation of them.

- 11.7** The whole journey of the stairlift shall be observable by the passenger at either landing (upper, intermediate and lower) where control switches for calling and sending the stairlift are installed.

12. Attendant-operated Stairlift

- 12.1** If the journey of the stairlift cannot be observable at the landing (upper, intermediate or lower), no control switch for calling and sending the stairlift shall be provided.

- 12.2** A detachable control box, for use upon the carriage only, with flexible cord not more than 1,500 mm in length shall be provided for the attendant to operate the stairlift by means of a continuous-pressure switch. A stopping device which conforms to Clause 9.3.2 shall also be provided in the control box.

- 12.3** No controls, other than a stopping device (Clause 9.3.2), shall be provided on the carriage.

13. User Guide and Operation Manual

- 13.1** User guide in both English and Chinese shall be affixed to the stairlift.
- 13.2** Operation manual laminated with plastic protective sheets shall be kept in the management office or the caretaker's office. If there is no management office or caretaker's office in the building, operation manual shall be affixed to the stairlift.

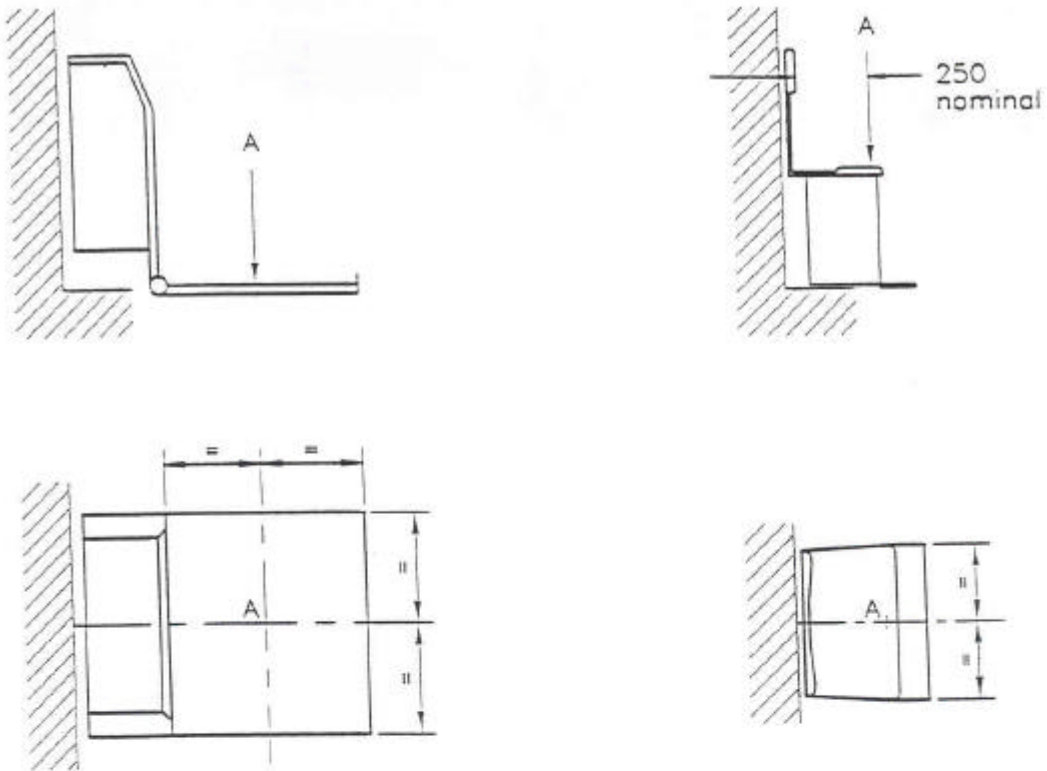

a) Wheel chair and standing passenger

b) Seated passenger

NOTE 1. Point A is the reference point for speed calculation.

NOTE 2. For stairlifts with combined seated and standing function, use a).

Dimensions in millimetres

Figure 1. Reference points for measuring rated speed

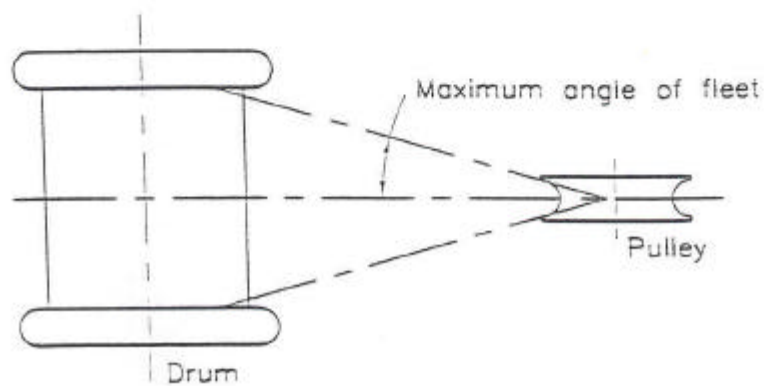

Figure 2. Angle of fleet

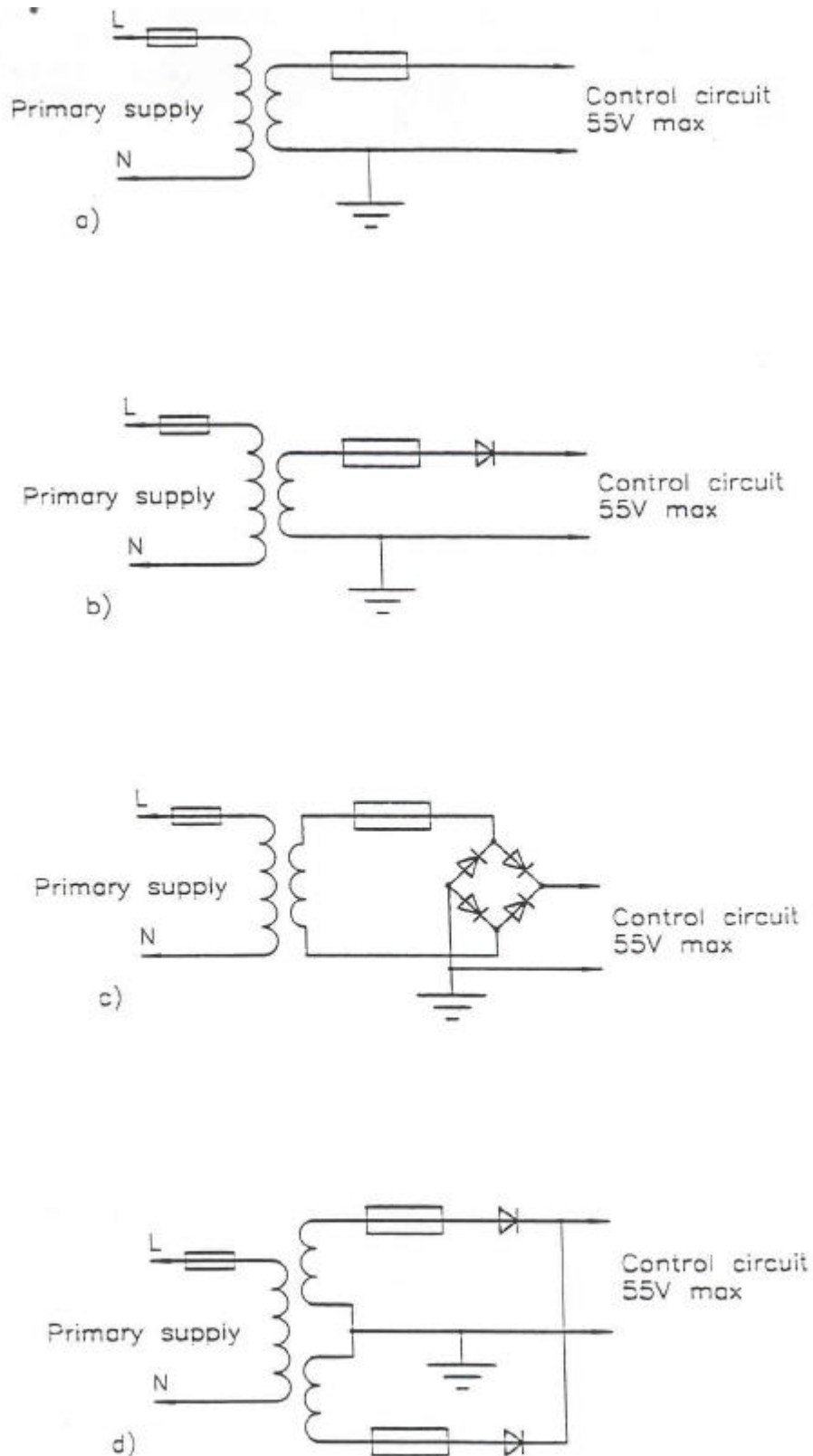
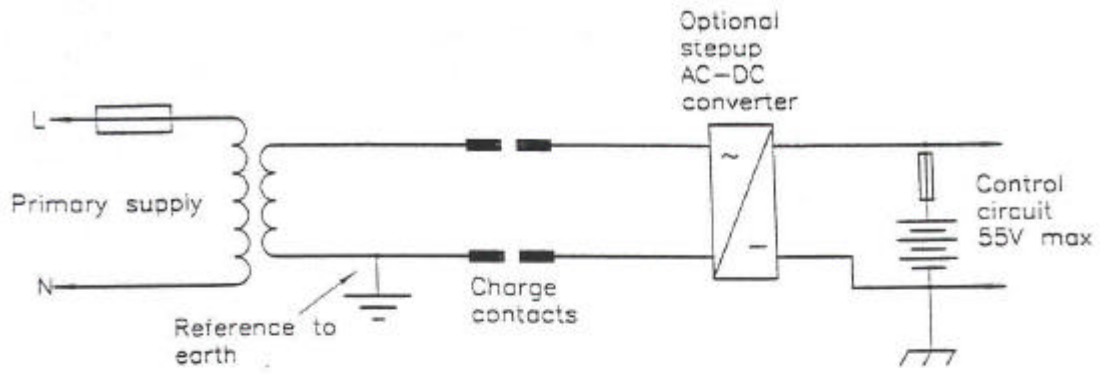
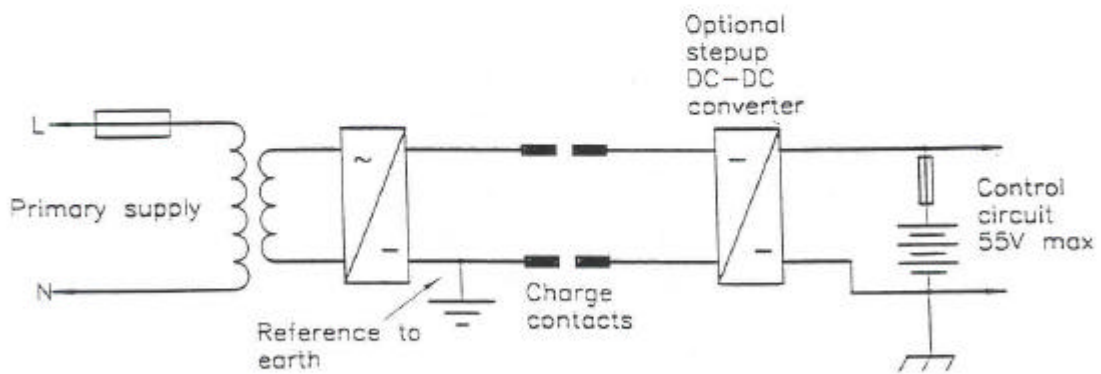

Figure 3. Typical control and supply circuit arrangement



a) AC charge contacts



b) DC charge contacts

Figure 4. Typical charging supply circuit for battery powered operation