

香港特別行政區政府
THE GOVERNMENT OF THE HONG KONG
SPECIAL ADMINISTRATIVE REGION

工作守則：氣體應用指南之九
CODE OF PRACTICE GU 09

用以從容水量少於 40 升
的石油氣瓶供氣的低壓調壓器
LOW PRESSURE REGULATORS FOR
SUPPLYING GAS FROM LPG CYLINDERS
HAVING LESS THAN 40 LITRES WATER CAPACITY



氣體安全監督
1998 年 8 月第二版
The Gas Authority
Issue 2, August 1998

THE GOVERNMENT OF THE HONG KONG
SPECIAL ADMINISTRATIVE REGION

CODE OF PRACTICE GU 09

LOW PRESSURE REGULATORS FOR
SUPPLYING GAS FROM LPG CYLINDERS
HAVING LESS THAN 40 LITRES WATER CAPACITY

The Gas Authority
Issue 2, August 1998

INDEX

Part 1	Scope and Terminology	page 1
Part 2	Selection of regulators	page 5
	2.1 Technical specification	
	2.2 Certification	
	2.3 Selection of manufacturers	
Part 3	Supply of regulators	page 12
	3.1 Documentation check upon delivery of imported regulators	
	3.2 Quality assurance of imported regulators	
	3.3 Supply of regulators to members of the public	
	3.4 Regulators found to be defective at customers premises.	
	3.5 Replacement of ageing regulators at customers premises	
Part 4	Installation and use of regulators	page 15
	4.1 Checks to be taken by registered gas installers (RGI)	
	4.2 Advice to customers	

- Appendix 1 Schematic diagram to show an example of one regulator type commonly used in Hong Kong (Section 2.1.2)
- Appendix 2 Regulator outlet nozzle dimensions (Section 2.1.3)
- Appendix 3 Typical example of operating limits for outlet pressure in accordance with the recognized standard (EN(prEN12864)) (Section 2.1.6)
- Appendix 4 Examples of sampling plan for quality assurance of regulators imported into Hong Kong (Section 3.2.2)
- Appendix 5 Local quality assurance tests to be carried out on regulators imported into Hong Kong (Section 3.2.3)
- Appendix 6 Quality assurance test report (Section 3.2.3)
- Appendix 7 Typical annual defect summary report
- Appendix 8 Typical examples of advice to customers for replacement of ageing regulators (Section 3.5.1)
- Appendix 9 Typical instructions for Registered Gas Installer (RGI) on commissioning of a cylinder regulator (Section 4.1.1)
- Appendix 10 Typical example of gas appliances and regulator check record (Section 4.1.2)
- Appendix 11 Typical example of advice to customers in the instruction leaflet provided by the manufacturer (Section 2.3.6)
- Appendix 12 Typical example of advice for the safe handling and use of regulators contained within a customer safety booklet (Section 4.2.1)
- Appendix 13 Typical example of warning label to customers on the need to replace ageing regulators (Section 4.2.2)

Part 1. Scope and Terminology

1.1 Scope

For the purpose of this code of practice the scope is confined to low pressure, rapid coupling type regulators to be connected to LPG cylinders having water capacities less than 40 litres.

1.2 References

The Gas Safety Ordinance Cap 51

The Gas Safety (Gas Supply) Regulations Cap51

The Gas Safety (Installation and Use) Regulations Cap51

The Gas Safety (Miscellaneous) Regulations Cap51

The Gas Safety (Registration of Gas Installers and Gas Contractors) Regulations Cap51

The Gas Safety (Registration of Gas Supply Companies) Regulations Cap51

prEN12864 Low pressure, non adjustable regulators having a maximum outlet pressure of less than or equal to 200mbar with a capacity of less than or equal to 4kg/h and their associated safety devices for butane, propane or their mixtures.

BS 3016 :1989 Pressure regulators and automatic changeover devices for liquefied petroleum gases.

ISO 9002: 1994 Quality systems - Model for quality assurance in production, installation and servicing.

JIS B8238 : 1984 Liquefied petroleum gas pressure regulators for domestic use.

EN 549 : 1995	Rubber materials for seals and diaphragms for gas appliances and gas equipment.
ISO 301 : 1981	Zinc alloy ingots intended for casting.
JIS H5301 : 1990	Zinc alloys die casting.
ISO 2859-2 : 1985	Sampling procedures for inspection by attributes Part 2. Specification for sampling plans indexed by limiting quality (LQ) for isolated lot inspection.

1.3 **Terminology**

AQL	Acceptable quality level.
EN standard	The European standard “ <i>Low pressure, non adjustable regulators having a maximum outlet pressure of less than or equal to 200mbar with a capacity of less than or equal to 4kg/h and their associated safety devices for butane, propane or their mixtures</i> ” which is currently in the latter stages of drafting and is expected to be finalised during 1999.
excess flow valve	A safety device which limits the flow of gas at the regulator outlet in the event of failure of downstream gas pipework.
gas distributor	distributor of LPG as defined regulation 2 of the Gas Safety (Registration of Gas Supply Companies) Regulations Cap51.
gas supply company	an LPG supply company registered in accordance with the Gas Safety (Registration of gas Supply Companies) Regulations Cap51.

gas tubing	flexible gas tubing (GSO/RT/2) approved in accordance with regulation 3 of Gas Safety (Miscellaneous) Regulation Cap 51.
LIA	Japan LP Gas Instrument Inspection Association (appointed by Ministry of International Trade and Industry).
lock-up	the action of the regulator valve to seal and prevent excessive rise in outlet pressure under conditions of zero flow.
low pressure	outlet regulator pressure pre-set at a nominal 29mbar (300 mm) and operating range within limits specified in the recognized international standard, (e.g. EN(prEN12864)).
LPG	liquefied petroleum gas as defined in section 2 of the Gas Safety Ordinance Cap 51.
LPG cylinder	a receptacle for containing LPG as defined in Section 2 of the Gas Safety Ordinance Cap 51 but excludes disposable cylinders. The term <i>cylinder</i> mentioned throughout this document refers to LPG containers having water capacities less than 40 litres.
Over-pressure relief	a device for the discharge of gas which opens to outside as soon as the gas pressure reaches a set pressure and closes when the monitored pressure has dropped.
rapid coupling	a system which enables a regulator to be secured to the cylinder valve without a threaded connection and without the use of tools as defined in the EN standard (equivalent to <i>clip-on</i> in BS 3016: 1989 section 1.2.19).

recognised	recognised by the Gas Authority, The Government of The Hong Kong Special Administrative Region.
RCA	recognised certification authority, means an independent organization recognised by the Gas Authority which is empowered under law or decree, (e.g. notified body appointed by the Commission of European Communities), to certify that a gas regulator is designed and produced in compliance with international, or national, safety standards.
registered gas contractor (RGC)	a gas contractor registered in accordance with the Gas Safety (Registration of Gas Installers and Gas Contractors) Regulations Cap 51.
registered gas installer (RGI)	a gas installer registered in accordance with the Gas Safety (Registration of Gas Installers and Gas Contractors) Regulations Cap 51.
regulator	a device which automatically controls pressure in a gas pipe down-stream of the device as defined in Section 2 of the Gas Safety ordinance Cap51 (<i>pressure regulator</i>). The term <i>regulator</i> mentioned throughout this document specifically refers to low pressure, rapid coupling models to be connected to LPG cylinders.

Part 2. Selection of regulators

2.1. Technical specification

2.1.1 General Requirements

Regulators shall be manufactured to recognised international standards, for example EN standard, LIA standard, BS3016, JIS B8238, in accordance with requirements contained therein concerning general construction, performance and test methods. In addition specific requirements in sections (2.1.2 – 2.1.7) shall apply.

2.1.2 Inlet connection

- (a) Inlet connections shall be of the rapid coupling type and shall comply with a recognised international standard, for example the EN standard, to ensure safety during connection to, or disconnection from, LPG cylinders and during operation. Where cylinder valves and corresponding regulators are procured from a number of different suppliers, gas supply companies shall be responsible for checking accuracy of critical dimensions to ensure compatibility. An example of a regulator type is shown in Appendix 1 for the purpose of illustrating terminology used in this code.
- (b) Inlet connections shall be constructed so as to ensure it shall not be possible under any circumstances for a user to connect incorrectly a regulator on to an incompatible cylinder valve. An effective means, such as colour coding, shall be employed by each gas supply company in addition to their company name or logo such that users can easily identify compatibility of regulator and cylinder valve connections.
- (c) Regulator components which are required to effect a gas-tight seal with the cylinder valve should be protected from impact damage and accumulation of dust or debris.

2.1.3 Outlet connection

The outlet gas tubing connection shall be in accordance with the drawing shown in Appendix 2.

2.1.4 Excess flow protection

The regulator shall incorporate an excess flow device. The excess flow device shall incorporate an automatic re-set feature and shall operate within a range of flow values specified in a recognised international standard, for example EN or LIA standard. However, the regulator shall not be fitted with over-pressure relief.

2.1.5 Materials

Materials selected shall conform to recognised international standards such as ISO 301 or JIS H 5301 in the case of zinc alloys and EN549 for rubber diaphragms/ seals and EN or LIA standard for non-metallic components, for example. Manufactured regulator components shall comply with mechanical strength and endurance requirements of recognised international standards such as EN or LIA standard.

2.1.6 Performance

The nominal regulated outlet pressure shall be set to 29 mbar. Operating limits of regulated outlet pressure shall be in accordance with an international standard for example EN or LIA standard, to correspond with typical inlet supply pressures and type of LPG distributed by gas supply companies in Hong Kong (typical range shown in Appendix 3).

2.1.7 Life expectancy

From 1 April 1997 the manufacturer shall declare the life expectancy of a regulator such that gas supply companies can comply with requirements in section (3.5). From 1 August 1997 the manufacturer shall indicate clearly, on the outer surface of the regulator, the year during which it needs to be replaced in both the Chinese and English language.

2.2 Certification.

2.2.1 Initial Type test (Primary) Certification

An initial type-test certificate for each model of regulator, confirming completion of tests in accordance with a recognised international standard and issued by a Recognised Certification Authority (RCA) in the country of origin, shall be forwarded by the manufacturer to the gas supply company prior to importation into Hong Kong.

2.2.2 Revalidation (Secondary) Certification

A manufacturer continuing to supply regulators to the Hong Kong market shall submit further production samples annually to the RCA for full approval testing so as to confirm continued use of materials in accordance with relevant international standard. The manufacturer shall arrange for an annual revalidation certificate produced by the RCA to be forwarded directly to each gas supply company purchasing the regulator. In addition, manufacturers' premises and production processes shall be subject to quality surveillance by the RCA in accordance with international quality standards.

2.2.3 Certificates of Compliance

Each batch of regulators imported into Hong Kong shall be accompanied by a certificate of compliance confirming manufacture to the recognised international standard, as declared in the primary certification, and country of origin.

2.3 Selection of manufacturers

2.3.1 Manufacturers intending to supply regulators into Hong Kong shall be inspected for compliance with this code by gas supply companies, or their representative(s), prior to selection and regularly thereafter within a period not exceeding 3 years.

2.3.2 Manufacturers shall produce regulators in accordance with recognised international standards. Product approval shall be obtained from an RCA and a type-test certificate forwarded to gas supply companies in accordance with sections (2.2.1 and 2.2.2). The production process shall be subject to quality surveillance in accordance with the RCA's approval procedures. Certificates of compliance shall be provided as required in section (2.2.3).

2.3.3 Manufacturers' production processes shall incorporate quality systems certified to a recognised international standard, such as ISO 9002, to ensure: -

2.3.3.1 Quality of components and materials supplied by sub-contractors which are critical to safe operation of regulators

- (a) Gas carrying components, or those components which affect the safe operation of a regulator, and are supplied by sub-contractors, shall be manufactured strictly in accordance with relevant international standards (e.g. section (2.1.5)).
- (b) Sub-contractors' quality systems should be certified to a recognised international standard such as ISO 9002. In particular quality assurance procedures shall include assessment of physical and mechanical properties of such components or materials. This shall include, for example, X-ray examination, or other equivalent means, of checking porosity in samples of die-cast zinc alloy components; spectrometric and chemical analysis of samples of rubber diaphragms and seals.
- (c) Such components and materials shall be subject to incoming inspection to ensure conformance with specification and relevant international standards. AQL's shall be applied in accordance with quality plan. Records of inspections and sub-contractors performance shall be maintained for periods not less than the expected useful life of each model of regulator.

2.3.3.2 Quality during stages of production

- (a) In accordance with approved quality plan, continuous 100% inspection and testing shall be incorporated within the production processes to control the manufacture and assembly of components critical in the safe performance of regulators.
- (b) Where gas carrying components, or those components which could affect the safe operation of a regulator, are manufactured prior to assembly, physical and mechanical properties of such components shall be evaluated. This shall include, for example, X-ray examination or other equivalent means (porosity check) and chemical analysis of zinc alloy components; and spectrometric and chemical analysis of rubber diaphragms and seals.
- (c) Mechanical endurance of regulator components shall be evaluated in addition to sub-assembly performance characteristics and soundness at critical stages in the production process. On line inspection, measuring and test equipment should be computer controlled to ensure objectivity of inspection / reporting processes and automatic re-calibration of instrumentation.

2.3.3.3 Quality of finished product.

Final inspection and testing shall be in accordance with approved quality plan to ensure finished models of regulator supplied to gas supply companies conform to specification and recognised international standards such as EN or LIA standard. This shall be achieved by a combination of batch testing in accordance with ISO 2859, or equivalent, at the manufacturing location and examination of samples submitted annually (section 2.2.2) to an RCA in the country of origin. Such testing shall include:-

- (i) verification of performance characteristics, including operation of integral excess flow device

- (ii) verification of constructional characteristics, including materials specification
- (iii) resistance to impact
- (iv) resistance to pressure (rupture test)
- (v) soundness (leakage less than 15cm³/h)
- (vi) mechanical strength of connections
- (vii) mechanical endurance
- (viii) soundness
- (ix) resistance to humidity changes
- (x) resistance to corrosion

2.3.4 Marking

The manufacturer shall ensure that a regulator displays essential information to include for example details of gas type, capacity, date of manufacture etc. in accordance with a recognised international standard such as EN or LIA standard. In addition a regulator shall display the gas supply company name or logo and carry a warning to the user of when it needs to be replaced. Such marking shall be durable, legible and clearly printed in the Chinese and English language.

2.3.5 Packaging

The manufacturer shall ensure that regulators are packaged so to afford maximum protection having due regard to market conditions in Hong Kong. Regulators shall be packed in individual boxes displaying outer markings on each box printed in either Chinese or English language.

2.3.6 User's Instructions

The manufacturer shall ensure that each regulator is supplied with a leaflet advising the user on how to operate the regulator safely. This shall include exchange of cylinder and the need to replace a regulator at the end of its useful life. The leaflets shall be printed in both Chinese and English language.

Part 3. Supply of regulators

3.1 Documentation check upon delivery of imported regulators

Gas supply companies shall have administrative procedures in place to ensure documentation associated with delivery of each shipment of imported regulators is scrutinised by designated staff before acceptance. In particular, the certificate of compliance (section 2.2.3) which identifies country of manufacture shall be confirmed against the original purchase orders. Any batch manufactured and dispatched from a location other than that specified in the original purchase order shall be rejected.

3.2 Quality assurance of imported regulators

3.2.1 Gas supply companies shall have written procedures which detail batch sampling methodologies, tests and reporting systems associated with quality assurance of imported shipments of regulators.

3.2.2 Sampling techniques for routine, non-destructive tests undertaken by gas supply companies shall be in accordance with a recognised standard, for example ISO 2859, to ensure numbers of regulators selected for routine examination are statistically significant and sampled by nominated personnel only (Appendix 4). During this period a new shipment shall remain segregated from other stocks until routine sampling and tests have been successfully completed.

3.2.3 Routine, non-destructive tests shall be carried out on regulators by trained personnel to check against manufacturers' specifications and international standards. Such tests shall include:-

- (a) physical dimensions
- (b) soundness
- (c) control of outlet pressure
- (d) lock-up pressure
- (e) operation of excess flow device

- (f) a limited quantity shall be subjected to the type of impact likely to be experienced during use (for example drop test)

Details of test procedures for the above are included in Appendix 5. Test results shall be entered on to a standard proforma (Appendix 6) and a data base shall be maintained for record purposes and be available for inspection by the Gas Authority.

- 3.2.4 If tests in section (3.2.2) result in the AQL (Appendix 4) being exceeded, the new shipment must remain segregated pending discussions with the manufacturer concerning arrangements for its rejection and subsequent return.
- 3.2.5 The suitability of materials employed in the construction of regulators supplied to Hong Kong shall be regularly confirmed by means of secondary certification from an RCA in accordance with section (2.2.2).

3.3 Supply of regulators to members of the public

Only gas supply companies shall select and import LPG cylinder regulators for supply to the public. From the 1 April 1997 all such regulators, supplied by approved gas distributors on behalf of gas supply company, must be provided on a supply and install basis only. Such installation work must be carried out by registered gas installers employed by registered gas contractors, for the purpose of installation in accordance with regulation 3 of the Gas Safety (Registration of Gas Installers and Gas Contractors) Regulations Cap51. No regulators shall be provided to members of the public on a supply only basis after the aforementioned date.

3.4 Regulators found to be defective at customers premises

- 3.4.1 Gas supply companies shall have documented procedures to ensure that defective regulators are removed from customers premises and returned to gas supply companies for further examination. Procedures should include for gas distributors providing a brief indication of nature of defects to accompany returned units.

- 3.4.2 Gas supply companies shall employ resources to receive and inspect returned defective regulators with a view to determining cause(s). They shall maintain a data base to monitor reliability of regulators and to identify any trends in defects. Such a data base should be used in order to compile an annual report (Appendix 7) to the Gas Authority. However, any cases of defect likely to have an impact upon public safety shall be reported without delay to the Gas Authority.

3.5. Replacement of ageing regulators at customers premises

- 3.5.1 As required under section (2.1.7), each regulator supplied by manufacturers from 1 August 1997 shall have a suitable warning label affixed advising the user (in Chinese and English language) of when it needs to be replaced. The date shall be based upon the date of manufacture (Appendix 8.1).
- 3.5.2 Existing stocks of new regulators delivered into store before the above date (section 3.5.1) and not yet installed will be suitably labelled by gas supply companies (Appendix 8.2).to indicate date for exchange.
- 3.5.3 In the case of regulators already installed in customers premises the stamped date of manufacture will be checked periodically by distributors in accordance with section (3.5.4.) below.
- 3.5.4 Gas supply companies shall maintain documented procedures requiring gas distributors' staff, regularly visiting customers, to check dates scheduled for replacement as displayed on regulators. Distributors staff shall undertake to remind customers of the need to replace periodically all regulators in accordance with the manufacturer's advice. Written notification to this effect should be provided by distributors to customers prior to expiry of the displayed replacement dates (section (4.2.2)).
- 3.5.5 Gas distributors shall not knowingly supply gas to an installation connected by a regulator which has not been replaced in accordance with the manufacturer's advice.

Part 4. Installation and use of regulators**4.1. Checks to be undertaken by registered gas installer (RGI)**

4.1.1 Gas supply companies shall ensure written instructions are provided in distributors' handbooks concerning the need to inspect the safe operation of regulators. RGI's shall pay particular attention to the condition and operation of regulators during initial commissioning (Appendix 9).

4.1.2 In addition, during regular safety inspections (18 month cycle) (Appendix 10), or any subsequent on-demand call to service a cylinder installation, the following checks should be carried out on the associated regulator:-

4.1.2.1 check for any visual signs of impact damage or deterioration

4.1.2.2 check for soundness

4.1.2.3 check outlet pressure

4.1.2.4 check replacement date is still valid

4.1.3 In accordance with regulation 23 (1) of the Gas Safety (Registration of Gas Installers and Gas Contractors) Regulations Cap 51 records to this effect shall be retained by registered gas contractors for a period of not less than 2 years. Any regulators found to be defective shall be replaced and returned to gas supply companies in accordance with section (3.4).

4.2. Advice to customers**4.2.1 New customers**

Gas supply companies shall ensure written instructions are provided in gas distributors' handbooks requiring RGI's to advise customers on taking care of regulators. This will include the safe exchange of cylinders and the eventual need for regulator replacement in

keeping with the advice label. An example of a leaflet describing how to use regulators safely is shown in Appendix 11. Safety handbooks given to new customers will also include a summary of such information in both Chinese and English language. A typical extract from a users handbook is shown in Appendix 12.

4.2.2 Existing customers

Gas supply companies shall ensure written instructions are provided in gas distributors handbooks concerning the need for RGI's and delivery men to remind customers of the need to take care of LPG cylinder regulators. This message should be communicated by means of the periodic reissue of safety handbooks from time to time. In accordance with section (3.5.4) written advice in both Chinese and English language should also be given to customers prior to expiry date for regulators. A typical example of notice is shown in Appendix 13.

- Appendix 1 Schematic diagram to show an example of one regulator type commonly used in Hong Kong (Section 2.1.2)
- Appendix 2 Regulator outlet nozzle dimensions (Section 2.1.3)
- Appendix 3 Typical example of operating limits for outlet pressure in accordance with the recognized standard (EN(prEN12864)) (Section 2.1.6)
- Appendix 4 Examples of sampling plan for quality assurance of regulators imported into Hong Kong (Section 3.2.2)
- Appendix 5 Local quality assurance tests to be carried out on regulators imported into Hong Kong (Section 3.2.3)
- Appendix 6 Quality assurance tests report (Section 3.2.3)
- Appendix 7 Typical annual defect summary report
- Appendix 8 Typical examples of advice to customers for replacement of ageing regulators (Section 3.5.1)
- Appendix 9 Typical instructions for Registered Gas Installer (RGI) on commissioning of a cylinder regulators (Section 4.1.1)
- Appendix 10 Typical example of gas appliances and regulator check record (Section 4.1.2)
- Appendix 11 Typical example of advice to customers in the instruction leaflet provided by manufacturers (Section 2.3.6).
- Appendix 12 Typical example of advice for the safe handling and use of regulators contained within a customer safety booklet (Section 4.2.1)
- Appendix 13 Typical example of warning of label to customers on the need to replace ageing regulators (Section 4.2.2)

Schematic diagram to show an example of
one regulator type commonly used in Hong Kong
(Section 2.1.2)

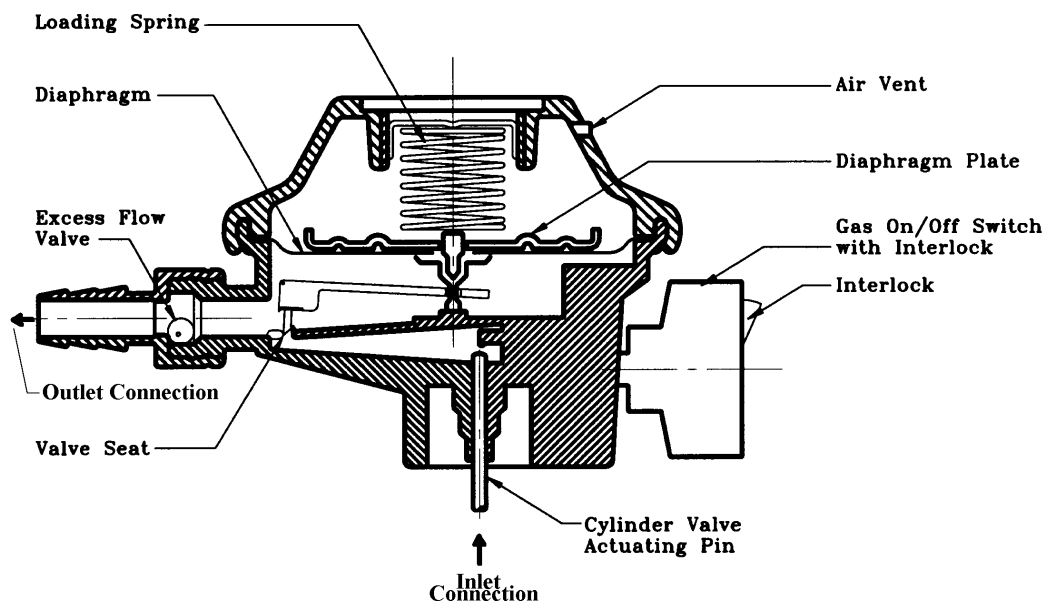

Regulator Outlet Nozzle Dimensions
(Section 2.1.3)

D1	D2	D3	D4	D5	D6
Ø8.2 Max	Ø10.0-Ø10.5	Ø12.2-Ø12.5	Ø12.7-Ø13.0	Ø13.2-Ø13.5	Ø11.0 -Ø11.5

L7	L8	R1	R2	ANG
6.4 -6.6	25.5 -26.5	R1.0 -R1.5	R0.3 -R0.5	11 ⁰ -13 ⁰

Dimensions in millimetres

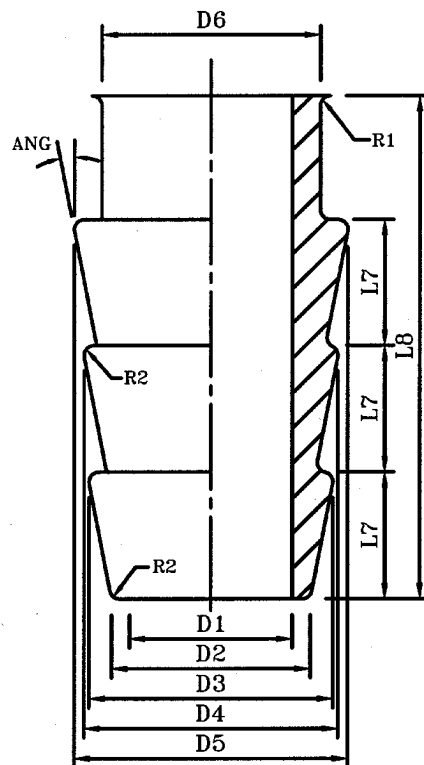

**Example of typical operating limits of regulator outlet pressure
in accordance with the recognized standards (e.g. EN(prEN12864))
(Section 2.1.6)**

Nominal regulated outlet pressure set at 29 mbar

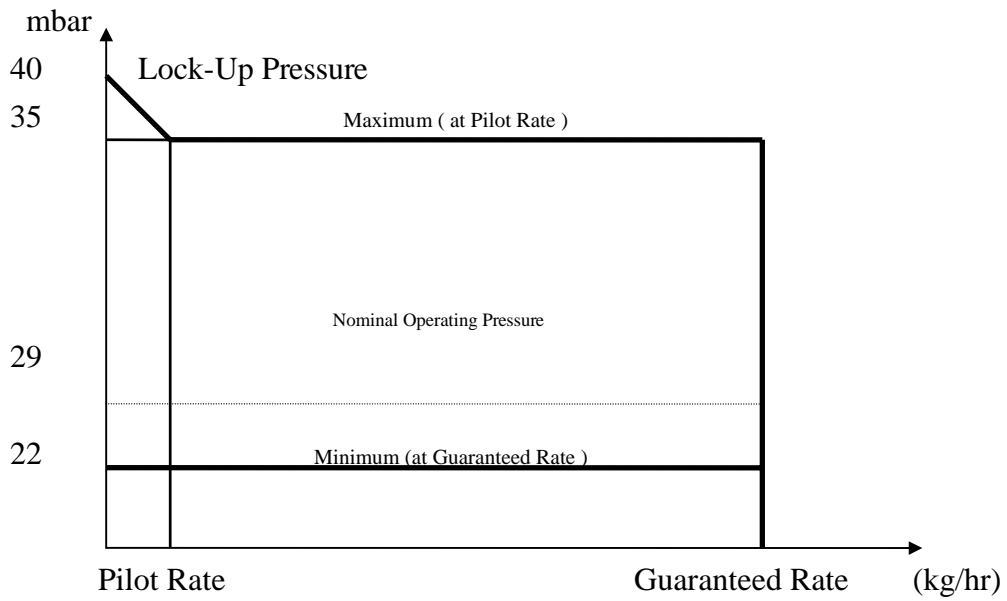

Gas Type : LPG (70 % Butane and 30 % Propane)
Typical regulator Inlet Pressure range : 0.3 - 7.5 bar
Maximum Regulator Lock-up Pressure : 40 mbar

**Examples of Sampling Plan for Quality Assurance
of Regulators Imported to Hong Kong**

(Section 3.2.2)

- (1) Apart from 100 % tests carried out at manufacturer's works, the gas supply companies shall take samples from their imported regulators for quality tests locally.
- (2) The local quality tests shall include the routine non-destructive and non-routine destructive tests as required in Clauses 3.2.3 and 3.2.5 of Part 3 of GU09 respectively.
- (3) The number of regulator units drawn from the imported batch for tests shall follow the requirements of ISO 9002, ISO 2859 and BS 6001 the latest edition.
- (4) The gas supply companies shall determine the sampling size code letters (i.e. quantities) in accordance with the general inspection level (GIL) II of BS 6001, Table 2a and 3 with the acceptable quality level (AQL) of not more than 1.0 % as per the attached tables as the minimum requirements for **physical tests** on their imported regulators. For examples: -
 - (a) J (i.e. 80) units of regulators for batch size of imported quantities ranging from 501 to 1,200 units shall be inspected and the numbers of failed regulators should not be more than 2 units. If the numbers exceed 3 units, the whole batch shall be rejected.
 - (b) M (i.e. 315) units of regulators for batch size of imported quantities ranging from 10,001 to 35,000 units shall be inspected and the numbers of failed regulators should not be more than 7 units. If the numbers exceed 8 units, the whole batch shall be rejected.
- (5) The gas supply companies shall not use the special inspection level (SIL) for those local quality assurance tests related to operational safety such as the functional tests as large sampling risks are tolerated at this level.
- (6) The gas supply companies shall determine the sampling size code letters (i.e. quantities) in accordance with the general inspection level (GIL) III of BS 6001, Table 2a, and 3 with acceptable quality level (AQL) of not more than 0.04 % as per the attached tables as the minimum requirements for **functional tests (i.e. soundness, lock up pressure tests, etc.)** on their imported regulators. For example:-

- (a) For batch size of 3,201 to 10,000 regulator units, M (i.e. 315) units shall be tested and only zero failure is allowed.

- (7) For **drop/impact tests, samples** of regulators for imported shipment size of 10,000 units or less shall be taken for tests in accordance with Table 2b. If the imported shipment exceeds 10,000 units, 0.15% of the lot shall be tested. Subsequent action, i.e. whether to retain or supply regulators to customers, shall be subject to manufacturer's advice.

Quality Plan

Table 2a --Sample Size Code Letters

(BS 6001: 1991 Table 2)

Lot or Batch Size	General Inspection Levels	
	II	III
2 to 8	A	B
9 to 15	B	C
16 to 25	C	D
26 to 50	D	E
51 to 90	E	F
91 to 150	F	G
151 to 280	G	H
281 to 500	H	J
501 to 1200	J	K
1201 to 3200	K	L
3201 to 10000	L	M
10001 to 35000	M	N
35001 to 150000	N	P
150001 to 500000	P	Q
500001 and over	Q	R

Table 2b – Sample Size for Drop / Impact Test

Lot or Batch Size	Sample Size / units
0 – 1000	2
1001 – 2000	3
2001 – 3000	5
3001 – 4000	6
4001 – 5000	8
5001 – 6000	9
6001 – 7000	11
7001 – 8000	12
8001 – 9000	14
9001 – 10000	15

Quality Plan

Table 3 - Single Sampling Plans for Normal Inspection
(BS 6001 : 1991 Table 3)

Sample Size Code Letter	Sample Sizes	Acceptable Quality Levels (Normal Inspection)							
		0.04		1.0					
		Accept	Reject	Accept	Reject				
A	2	↓							
B	3								
C	5								
D	8					↓			
E	13								
F	20								
G	32					↑			
H	50								
J	80								
K	125					↓			
L	200								
M	315								
N	500					↑			
P	800								
Q	1250								
R	2000				↑				

↓ * Use first sampling plan below arrow. If sample size equals, or exceeds, lot or batch size, carry out 100% inspection.

↑ * Use first sample sampling plan above arrow

Accept * Acceptance Number

Reject * Rejection Number

Appendix 5
Local Quality Assurance Tests To Be Carried Out
On Regulators Imported into Hong Kong
(Section 3.2.3)

A. Inspection and Check including Connector Dimensions

- (A1) The regulator shall be physically checked including the colour and the shape. All external parts shall be free from sharp edges, corners and any defects which might cause damage, injury or incorrect operation.
- (A2) Check if there are any signs of impact damage or deterioration on the regulator body.
- (A3) Check if there is any clear label indicating the replacement date on the regulator.
- (A4) The diameters of the inlet and outlet connection of the regulator shall be checked and measured against the manufacturers' drawings.
- (A5) The matching of the regulator to the corresponding LPG cylinder valve shall be checked and ensure that they are fit to each other in term of dimensions.
- (A6) The colour coding system for both regulator and the cylinder shall be checked and ensure that they match each other consistently.

B. Drop Test

- (B1) The regulator shall be tested by dropping from a height of 1m in any position on to a hard surface (e.g. bricks or concrete). After the test the regulator shall remain functional and meet the requirements of the EN standard or equivalent.

C. Soundness Test

- (C1) The completed regulator shall be tested at a pressure of 150 mbar applied through the outlet connection and held for a period of not less than 60 sec in accordance with EN standard or equivalent and check for soundness using soapy solution.

- (C2) The completed regulator shall then be tested on those parts which are normally subjected to cylinder pressure at a pressure of 14 bar applied through the inlet connection and held for a period of not less than 120 sec with the outlet connection sealed in accordance with EN standard or equivalent and check for soundness using soapy solution.

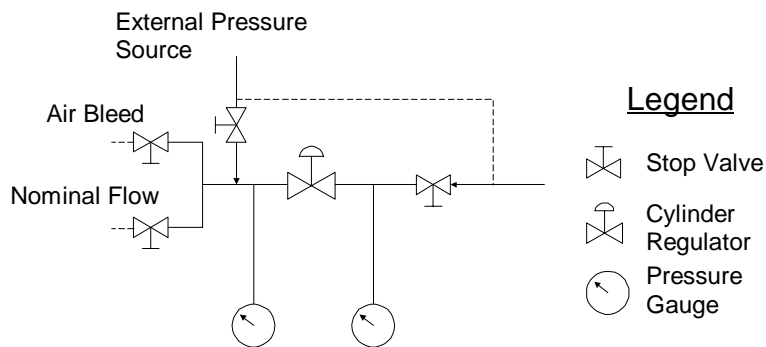

General arrangement of equipment for routine, non-destructive tests

Note : All performance tests shall be conducted with air or inert gas as medium.

In case of (C1) and (C2) above, the regulator shall be considered to be leaktight if no bubbles are observed

D. Regulated outlet pressure

The nominal outlet pressure (29 mbar in section (2.1.6)) and respective operating limits shall be checked in accordance with the relevant international standard (e.g. EN) and manufacturers' advice. For determining operating limits, the following shall apply: -

(D1) Minimum outlet pressure

- 1.1 The flow rate through the regulator shall be set at the guaranteed rate declared by the manufacturer.
- 1.2 The inlet gas pressure shall be set to the minimum value specified in the relevant international standard (e.g. EN), strictly in accordance with the gas type distributed by the Gas Supply Company in Hong Kong.
- 1.3 The corresponding value of regulated outlet pressure shall not be less than the value specified in the relevant international standard (e.g. EN), strictly in accordance with the gas type distributed by the Gas Supply Company in Hong Kong in order that installed gas appliances can

operate safely and efficiently.

(D2) Maximum outlet pressure

- 2.1 The flow rate through the regulator shall be set at the pilot rate (15 g/h in EN) declared by the manufacturer.
- 2.2 The inlet gas pressure shall be set to the maximum value specified in the relevant international standard (e.g. EN), strictly in accordance with the gas type distributed by the Gas Supply Company in Hong Kong.
- 2.3 The corresponding value of regulated outlet pressure shall not exceed the value specified in the relevant international standard (e.g. EN), strictly in accordance with the gas type distributed by the Gas Supply Company in Hong Kong in order that installed gas appliances can operate safely and efficiently.

E. Lock-up Pressure Test

- (E1) The regulator shall be tested and ensured that the device shall lock-up at a pressure not exceeding 40 mbar in accordance with the EN standard or equivalent when flow is reduced to zero from nominal conditions over a period of 2 seconds.
- (E2) Close the normal flow valve with the inlet valve open and check if the action of the regulator valve seal and prevent excessive rise in outlet pressure reading from the outlet pressure gauge.
- (E3) The lock-up action shall be achieved at not more than 60 seconds after cessation of flow.

F. Excess Flow Valve Functional Test

- (F1) The integral excess flow valve of the regulator shall be checked to ensure that the valve can shut off the gas rate immediately when the rubber tubing is disconnected.

附錄 6 Appendix 6

品質保證測試報告

(第 3.2.3 段)

Quality Assurance Test Report

(Section 3.2.3)

氣體供應商 Gas Supply Co		調壓器測試紀錄 Testing Record for Regulators													訂單號 PO No.		
		檢查 Inspection & Check					接頭尺寸 Connector Dimensions			測試介質 Testing Medium :					簽名/日期 Signature/Date		
										測試 Tests							
批號 Batch No.	規格型號 Specification and Model	鋒銳邊沿及尖角 Sharp Edges & Corners	外在部分 External	貼有標籤 Labelled	其他 Other	入口接頭直徑 Inlet Connection Diameter	出口接頭直徑 Outlet Connection Diameter	石油氣瓶閥與調壓器的配合 LPG Cylinder Valve to Regulator Match	下墜測試 Drop Test	氣密測試 Soundness Test		標稱出口壓力 Nominal Outlet Pressure mbar 毫巴		鎖定壓力測試 Lock-up Pressure Test	溢流控制閥功能測試 Excess Flow Valve Functional Test	測試人 Test Operator	監督人 Supervisor
										通過出口持續施加 150毫巴的壓力60秒 150mbar Through Outlet 60 sec.	通過入口持續施加 14巴的壓力120秒 14 bar Through Inlet 120 sec.						
		(A1)	(A2)	(A3)		(A4)	(A4)	(A5)	(B1)	(C1)	(C2)	(D1)	(D2)	(E1-E3)	(F1)		
備註 Remarks																	

Appendix 7

Annual defect summary report for the period _____

Model type : _____

Supplier : _____

No. Imported : _____

No. Supplied : _____

Age of Installed Regulators (Years)	Defect Codes							Remarks
	01	02	03	04	05	→	η	
<1								
1 - 2								
2 - 3								
3 - 4								
4 - 5								
5 - 6								
6 - 7								
7 - 8								
>8								
Total Defects by Category								
Total Number of Defects								

Note :- Defect Codes to be allocated by the Gas Supply Company.

Appendix 8

Typical Examples of Advice to Customers for Replacement of Ageing regulators (Section 3.5.1)

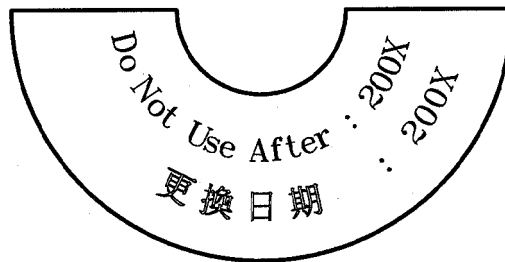

8.1 : Label supplied by regulator manufacturer for regulator manufactured after 1 April 1997



8.2 : Label supplied by gas supply companies for existing stocks of regulators delivered before 1 April 1997

Appendix 9
Typical Instructions for Registered Gas Installer (RGI)
on Commissioning of a cylinder Regulators
(Section 4.1.1)

- 1 The RGI shall connect the regulator to the flexible gas tubing of approved type (i.e. GSO-RT-2) securely using suitable gas tubing clips.
- 2 A temporary tee-piece complete with pressure gauge shall be connected in between the flexible gas tubing and the appliance for checking outlet pressure, soundness and lock up pressure as below: -

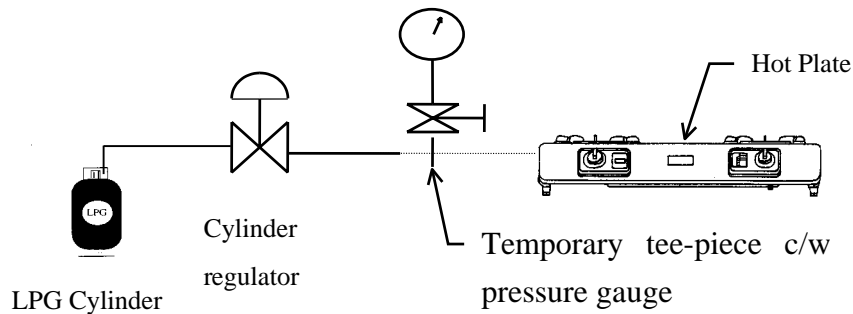

- 3 Connect the regulator to cylinder and switch on the regulator allowing gas flow without turning on the gas appliance, check outlet pressure in accordance with manufacturer's specification.
- 4 Soapy water shall be applied to check leak at valve and entire regulator body, gas tubing connections at regulator and appliance.
- 5 Turn on the appliance and test its function. This should be carried out in line with the appliance manufacturer's instructions. Check outlet pressure in accordance with manufacturer's specification.
- 6 After the tests, remove the temporary tee-piece and connect the flexible gas tubing directly to the appliance. Re-test this connection with soapy water and ensure that no leakage of gas is found.
- 7 A copy of instructions on safe handling and use of regulator shall be left for the customer's information after the commissioning.

Appendix 10

**Table 5 - Typical example of gas appliances and regulator Check Record
(Section 4.1.2)**

Distributor : _____ Tel. No _____																									
Address : _____																									
Customer's A/C No. :	Customer's Name _____																								
Customer's Tel. No. _____																									
Address : _____																									
(A)	(This part should be completed by the RGI)																								
Gas Installation	<table style="width: 100%; border-collapse: collapse;"> <thead> <tr> <th style="width: 80%;"></th> <th style="width: 10%; text-align: center;">Normal</th> <th style="width: 10%; text-align: center;">Replacement/ Improvement required</th> </tr> </thead> <tbody> <tr> <td>LPG Cylinder _____x _____Kg _____x _____Kg</td> <td style="text-align: center;"><input type="checkbox"/></td> <td style="text-align: center;"><input type="checkbox"/></td> </tr> <tr> <td>Regulator : Manufacture Date _____ Model _____ (Recommended to be replaced in accordance with manufacturer's guidance)</td> <td style="text-align: center;"><input type="checkbox"/></td> <td style="text-align: center;"><input type="checkbox"/></td> </tr> <tr> <td>Outlet gas pressure :</td> <td style="text-align: center;"><input type="checkbox"/></td> <td style="text-align: center;"><input type="checkbox"/></td> </tr> <tr> <td>Flexible gas tubing : Manufacture date _____ (Recommended to be replaced after 3 years at most)</td> <td style="text-align: center;"><input type="checkbox"/></td> <td style="text-align: center;"><input type="checkbox"/></td> </tr> <tr> <td>Gas tubing clip</td> <td style="text-align: center;"><input type="checkbox"/></td> <td style="text-align: center;"><input type="checkbox"/></td> </tr> <tr> <td>Position of the LPG cylinder(s)</td> <td style="text-align: center;"><input type="checkbox"/></td> <td style="text-align: center;"><input type="checkbox"/></td> </tr> <tr> <td>Leakage test</td> <td style="text-align: center;"><input type="checkbox"/></td> <td style="text-align: center;"><input type="checkbox"/></td> </tr> </tbody> </table>		Normal	Replacement/ Improvement required	LPG Cylinder _____x _____Kg _____x _____Kg	<input type="checkbox"/>	<input type="checkbox"/>	Regulator : Manufacture Date _____ Model _____ (Recommended to be replaced in accordance with manufacturer's guidance)	<input type="checkbox"/>	<input type="checkbox"/>	Outlet gas pressure :	<input type="checkbox"/>	<input type="checkbox"/>	Flexible gas tubing : Manufacture date _____ (Recommended to be replaced after 3 years at most)	<input type="checkbox"/>	<input type="checkbox"/>	Gas tubing clip	<input type="checkbox"/>	<input type="checkbox"/>	Position of the LPG cylinder(s)	<input type="checkbox"/>	<input type="checkbox"/>	Leakage test	<input type="checkbox"/>	<input type="checkbox"/>
	Normal	Replacement/ Improvement required																							
LPG Cylinder _____x _____Kg _____x _____Kg	<input type="checkbox"/>	<input type="checkbox"/>																							
Regulator : Manufacture Date _____ Model _____ (Recommended to be replaced in accordance with manufacturer's guidance)	<input type="checkbox"/>	<input type="checkbox"/>																							
Outlet gas pressure :	<input type="checkbox"/>	<input type="checkbox"/>																							
Flexible gas tubing : Manufacture date _____ (Recommended to be replaced after 3 years at most)	<input type="checkbox"/>	<input type="checkbox"/>																							
Gas tubing clip	<input type="checkbox"/>	<input type="checkbox"/>																							
Position of the LPG cylinder(s)	<input type="checkbox"/>	<input type="checkbox"/>																							
Leakage test	<input type="checkbox"/>	<input type="checkbox"/>																							
(B)	(This part should be completed by the RGI)																								
Appliances	<table style="width: 100%; border-collapse: collapse;"> <tr> <td style="width: 20%;">Cooking appliance</td> <td style="width: 10%;">Safe <input type="checkbox"/></td> <td style="width: 10%;">Unsafe <input type="checkbox"/></td> <td style="width: 60%;">Recommendation : _____</td> </tr> <tr> <td>Brand / model _____</td> <td colspan="3">_____</td> </tr> <tr> <td>Water heater</td> <td>Safe <input type="checkbox"/></td> <td>Unsafe <input type="checkbox"/></td> <td>Recommendation : _____</td> </tr> <tr> <td>Brand / model _____</td> <td colspan="3">_____</td> </tr> </table>	Cooking appliance	Safe <input type="checkbox"/>	Unsafe <input type="checkbox"/>	Recommendation : _____	Brand / model _____	_____			Water heater	Safe <input type="checkbox"/>	Unsafe <input type="checkbox"/>	Recommendation : _____	Brand / model _____	_____										
Cooking appliance	Safe <input type="checkbox"/>	Unsafe <input type="checkbox"/>	Recommendation : _____																						
Brand / model _____	_____																								
Water heater	Safe <input type="checkbox"/>	Unsafe <input type="checkbox"/>	Recommendation : _____																						
Brand / model _____	_____																								
(C)	Other Suggestion																								
	<table style="width: 100%; border-collapse: collapse;"> <tr> <td style="width: 80%;">1. LPG cylinders which have a nominal aggregate water capacity of 130 litres or above and which contain or have once contained LPG should not be stored.</td> <td style="width: 20%; text-align: center;"><input type="checkbox"/></td> </tr> <tr> <td>2. The regulator should be turned off after use each time.</td> <td style="text-align: center;"><input type="checkbox"/></td> </tr> <tr> <td>3. After the regulator is disconnected, the cylinder valve should be fully closed.</td> <td style="text-align: center;"><input type="checkbox"/></td> </tr> <tr> <td>4. LPG cylinders and regulators should be handled with care, LPG cylinders should be kept in an upright position.</td> <td style="text-align: center;"><input type="checkbox"/></td> </tr> <tr> <td>5. Only cooking appliances which meet the required standard should be used,</td> <td style="text-align: center;"><input type="checkbox"/></td> </tr> <tr> <td>6. Regulators shall be replaced on or before the expiry date shown on the label.</td> <td style="text-align: center;"><input type="checkbox"/></td> </tr> <tr> <td>7. Warning labels shall be displayed at prominent places</td> <td style="text-align: center;"><input type="checkbox"/></td> </tr> </table>	1. LPG cylinders which have a nominal aggregate water capacity of 130 litres or above and which contain or have once contained LPG should not be stored.	<input type="checkbox"/>	2. The regulator should be turned off after use each time.	<input type="checkbox"/>	3. After the regulator is disconnected, the cylinder valve should be fully closed.	<input type="checkbox"/>	4. LPG cylinders and regulators should be handled with care, LPG cylinders should be kept in an upright position.	<input type="checkbox"/>	5. Only cooking appliances which meet the required standard should be used,	<input type="checkbox"/>	6. Regulators shall be replaced on or before the expiry date shown on the label.	<input type="checkbox"/>	7. Warning labels shall be displayed at prominent places	<input type="checkbox"/>										
1. LPG cylinders which have a nominal aggregate water capacity of 130 litres or above and which contain or have once contained LPG should not be stored.	<input type="checkbox"/>																								
2. The regulator should be turned off after use each time.	<input type="checkbox"/>																								
3. After the regulator is disconnected, the cylinder valve should be fully closed.	<input type="checkbox"/>																								
4. LPG cylinders and regulators should be handled with care, LPG cylinders should be kept in an upright position.	<input type="checkbox"/>																								
5. Only cooking appliances which meet the required standard should be used,	<input type="checkbox"/>																								
6. Regulators shall be replaced on or before the expiry date shown on the label.	<input type="checkbox"/>																								
7. Warning labels shall be displayed at prominent places	<input type="checkbox"/>																								
Note : Please delete Part B if it is not applicable.																									
_____ Customer's signature	_____ RGI signature																								
I understand the content of the above recommendations and certify that the safety check has been completed.																									
	Date of check _____																								

Appendix 11

Typical example of advice to customers in the instruction leaflet provided by the Manufacturer

(Section 2.3.6)

1. General

- 1.1 The regulator must only be used with an L.P. gas cylinder fitted with a matching valve which has the same coupling dimension as the regulator as specified by your gas supplier. If you have any doubt, contact your gas supplier.
- 1.2 The cylinder must always be kept in the upright position.
- 1.3 If the regulator is used outdoors, it must be protected from exposure to water, that is rain, etc.
- 1.4 No tools are required to operate the valve and regulator. Only authorized personnel can repair the valve and regulator.

MANUFACTURER TO SHOW DIAGRAM OF REGULATOR

2. Connecting the Regulator

- 2.1 Make sure that all taps and appliances are turned off.
- 2.2 Make sure that the installed flexible gas tubing rubber hose is still in good condition; not more than 3 years old.
- 2.3 A cylinder must not be changed in the presence of naked lights, or whilst smoking etc. Remove the protection cap on top of the cylinder valve by pulling the strap out and upwards, the cap will then lift off the valve.

Note : Always fit the cap on to the cylinder valve when the cylinder is empty or not connected. Press the cap down with a firm pressure until a click sound is heard.

2.4 Describe how the regulator should be connected securely.

MANUFACTURER TO
SHOW DIAGRAM

2.5 Describe in detail how the switch is positioned with gas-off incorporating safety feature with switch off before connection is possible.

MANUFACTURER TO
SHOW DIAGRAM

3. Turning the Gas “ON” & “OFF”

3.1 Describe how the gas is turned “ON” in connection with safety switch as described in 2.5.

MANUFACTURER TO
SHOW DIAGRAM

3.2 Describe how the gas is turned “OFF” in connection with safety switch as described in 2.5.

MANUFACTURER TO
SHOW DIAGRAM

SAFETY N.B. If the burner flames do not go out when the gas is turned off, do not remove the regulator. Return regulator to the “ON” position and leave the appliance alight. Contact your gas supplier immediately and do not touch the appliance or regulator until the supplier has dealt with the fault.

4. Disconnecting the Regulator

Describe in detail how the regulator can be disconnected safely by “Turning the Switch off First” as a required safety regulator as described in 2.5, incorporating as many steps and pictures as necessary.

NOTE : NEVER TURN THE SWITCH TO THE “DISCONNECT” POSITION WHEN THE BURNER IS ALIGHT. Wait until the burner and pilot go out, then, and only then, turn the switch to the “Disconnect” position.

5. Excess flow Valve

5.1 The regulator is equipped with an excess flow valve which cuts off the gas flow automatically, if the flow exceeds higher than the rated capacity in case of ruptured gas tubing or the gas tubing being pulled off.

5.2 Please note that after the excess flow valve has cut off the gas flow, a small amount of gas may still pass through the nozzle. The switch must therefore be turned to the “OFF” position immediately, and the gas tubing and installation must be inspected and tested for leaks. Soapy water may be used for leak detection. Brush the flexible gas tubing and all the connections with soapy water, a gas leak will form bubbles.

5.3 Never use a naked flame for leak detection

5.3.1 If you detect a leak do not turn the gas supply back on. Open all windows wide, extinguish naked flames and contact your gas supply company urgently. Do not operate any electrical switch.

5.3.2 If no fault is noticed, then make sure that all taps are in the “OFF” position and wait for approximately 30 seconds before trying to light the burner again. If the excess-flow valve continues to cut off the gas, call your gas supplier as soon as possible.

6. Ventilation

6.1 All gas appliances consume air, and it is important to ensure that each room or compartment containing a gas appliance has adequate ventilation. Contact your gas supply company if you are not sure.

6.2 L.P. Gas is heavier than air and will sink to the floor. In no circumstances should L.P. Gas cylinders be left or used in basements or below ground level.

Appendix 12

Typical example of advice for the Safe Handling and Use of Regulators Contained within a customer Safety Booklet

(Section 4.2 1)

Safe Handling and Use of Regulators

1. In compliance with the Gas Safety Ordinance and to ensure safety, installation of LPG appliances and pipes must be always carried out by Registered Gas Installers (RGI). You cannot attempt to do it yourself.
2. Connecting the Regulator
 - 2.1 Each LPG cylinder is sealed to ensure that the quality and quantity comply with the required standards. Please remove the cylinder seal before attempting to connect the regulator.
 - 2.2 Ensure that the switch of the regulator is in the 'off' position.
 - 2.3 Place the regulator over the cylinder valve and press it down slowly.
[The connecting method stated in the Appendix 11 will be incorporated into the Safety Booklet]
3. Before turning the regulator switch to 'ON' position, please turn off all the gas appliances. Then turn on the switch of the regulator. The appliances should not be used unless no leakage is detected. If leakage is detected ensure the regulator be in the "OFF" position and take appropriate measures as described in [*Cross reference to section on how to deal with gas escapes safely*]
4. Disconnecting the Regulator
 - 4.1 Turn the switch of the regulator to the 'off' position.
 - 4.2 Disconnection of the regulator is completed only after it is separated from the LPG cylinder valve. *[The disconnecting method stated in the Appendix 11 will be incorporated into the Safety Booklet.]*

5. When connecting or disconnecting the regulator, care should be taken to avoid it from dropping to the ground or striking any object.
6. The regulator must be replaced on or before the expiry date.
7. If the regulator is not replaced when it expires , gas suppliers will not continue to supply gas to you.
8. If you are not using your gas appliance(s), do not forget to turn off the regulator.
9. You should use gas appliances as approved by the Government. For enquiries, please contact your LPG dealer.

Appendix 13

附錄 13

Typical Example of Warning Label to Customers
on the Need to Replace Ageing Regulators
提醒客戶需要更換陳舊調壓器的警告標籤典型例子
(Section 4.2.2)

Warning Note 警告

LPG Cylinder Regulator 石油氣瓶調壓器

**In the interest of gas safety, your LPG cylinder regulator(s)
need to be replaced on or before _____.**
為安全起見，你的石油氣瓶調壓器必須於_____或之前更換。

**If you do not replace the regulator(s) on or before the said
date, the gas supplier can not continue to supply gas to your
premises.**

如至上述日期你仍未有石油氣瓶調壓器調壓器，氣體供應商可停止
為府供應氣體上

Gas Supplier 氣體供應商 _____

Date 日期 _____