

Code of Practice
for
Hong Kong LPG Industry

Module 1
LPG Compounds
and
Cylinder Stores

Issue 2, September 1999

Module 1 LPG Compounds and Cylinder Stores

Contents

	Page
PREFACE	
SECTION 1 INTERPRETATION OF TERMS	1
SECTION 2 OBJECTIVES AND SCOPE	4
2.1. Objectives	4
2.2. Scope	4
2.3. Regulations and References	5
SECTION 3 PLANT LOCATION AND SAFETY REQUIREMENTS	8
3.1. LPG Compounds	8
3.1.1. General Requirements	8
3.1.2. Site Fence	8
3.1.3. Bulk Tank Location	9
3.1.4. Tanker Bay	10
3.1.5. Fill-connection	10
3.2. Cylinder Stores	11
3.2.1. General Requirements	11
3.2.2. Radiation Walls	13
3.3. Vaporiser Location	13
SECTION 4 DESIGN	15
4.1. General Requirements	15
4.1.1. Equipment and Materials	15
4.1.2. Drawings and Records	15
4.2. Bulk Tanks	15
4.2.1. Design and General Requirements	15
4.2.2. Vessel Chamber	17
4.2.3. Supports	18
4.2.4. Corrosion Protection	18
4.2.5. Pressure Relief Valve for Bulk Tank	19
4.2.6. Filling Level and Content Gauge	20
4.2.7. Inspection Hole and Other Connections	21
4.3. Piped-cylinder Stores	22
4.3.1. General	22
4.3.2. Flexible Gas Tubing (Pigtail)	22
4.3.3. Safety Devices	22
4.3.4. Change-over Devices	22
4.4. Vaporisers	23
4.4.1. General	23
4.4.2. Pressure Relief Valve for Vaporiser	24
4.4.3. Heat and Liquid Controls	24
4.5. Pressure Regulators	24
4.5.1. Design Criteria	24
4.5.2. Primary Pressure Regulator	25
4.5.3. Secondary Pressure Regulator	25
4.6. Pipework and Fittings	26

4.6.1.	General Requirements	26
4.6.2.	Materials and Construction	27
4.6.3.	Hydrostatic Pressure Relief Valve	27
4.6.4.	Valving	28
4.7.	Drain Connections	28
4.8.	Ventilation and Explosion Relief	28
4.8.1.	General	28
4.8.2.	Natural Ventilation	29
4.8.3.	Explosion Relief	30
SECTION 5	FIRE PRECAUTIONS	32
SECTION 6	ELECTRICAL REQUIREMENTS AND ELECTROSTATIC PRECAUTIONS	33
6.1.	Electrical Requirements	33
6.1.1.	Hazardous Area Classification	33
6.1.2.	Electrical Equipment	33
6.2.	Electrostatic Precautions	33
SECTION 7	INSTALLATION	35
7.1.	General	35
7.2.	Bulk Tanks	35
7.3.	Vaporisers	35
7.4.	Pipework and Fittings	36
7.5.	Cathodic Protection	36
SECTION 8	TESTING AND COMMISSIONING	38
8.1.	General	38
8.2.	Bulk Tank and Vaporiser Testing	38
8.3.	Pipework Testing	39
8.4.	Purging into Service	40
8.5.	Purging out of Service	41
8.6.	Commissioning	42
SECTION 9	OPERATION	43
9.1.	General	43
9.2.	Replenishment of LPG Tanks	43
9.3.	Replacement of LPG Cylinders	44
9.4.	Miscellaneous	45
SECTION 10	MAINTENANCE, EXAMINATIONS AND INSPECTIONS	46
10.1.	General	46
10.2.	Maintenance	46
10.3.	Tests, Examinations and Inspections	47
10.3.1.	General	47
10.3.2.	LPG Tanks	47
10.3.3.	Vaporisers and Pipework	48
10.3.4.	LPG Compounds and Cylinder Stores	48

APPENDICES

- A** Relevant Sections in Relation to the Gas Safety (Gas Supply) Regulations
- B** Acceptance Criteria for Competent Person Under Gas Safety Ordinance, Cap. 51
 - 1. Class 1 - Testing and Certification of LPG Cylinders, Tanks, Vaporisers and Mains
 - 2. Class 2 - Inspection and Certification of LPG Compounds and Cylinder Stores
- C** Practice Note for Authorised Persons and Registered Structural Engineers for Gas Supply Installations
- D** Minimum Safety Distances for Underground/Mounded LPG Bulk Tanks
- E** Typical Design for LPG Trap
- F** Typical Schematic Diagram for LPG Compound
- G** Typical Schematic Diagram for Piped-cylinder Store
- H** Area Classification for LPG Compound and Cylinder Store
- I**
 - 1. Testing and Examination Report of LPG Tank
 - 2. Testing and Examination Report of LPG Vaporiser
 - 3. Testing and Examination Report of LPG Pipes
- J** Annual Inspection Report of LPG Installation
- K** Summary of Tests, Examinations and Inspections

PREFACE

This document is the first in a series of modules as Code of Practice for the LPG industry in Hong Kong. The other 7 modules are :

- Module 2 Underground LPG Pipework
- Module 3 Handling and Transport of LPG in Bulk by Road
- Module 4 Aboveground Distribution Pipes, Service Risers, Downers and Ring Mains
- Module 5 Domestic Installations
- Module 6 Non-Domestic Installations
- Module 7 Operating Procedures for Emergencies for LPG Compounds and Cylinder Stores
- Module 8 Operating Procedures for Emergencies for Installations outside LPG Compounds/Stores.

Module 1 lays down recommended practice for all LPG compounds and cylinder stores, including standby cylinder stores at consumer outlets including all associated equipment within the installations. This module shall be read in conjunction with the Gas Safety Ordinance (Cap. 51) and subsidiary regulations (See Appendix A for reference).

The basis for development of this document is the Standard Practice Manuals prepared by Congas (Volume 1 & 2), the Code of Practice by the LP Gas Association in U.K., the safety requirements issued by the Gas Standards Office and the Fire Services Department in Hong Kong.

This module has been prepared jointly by the Gas Standards Office and the LPG Safety and Technical Committee represented by registered gas supply companies in Hong Kong LPG industry.

While this module tends to be specific in important aspects affecting safety and reliability, it shall be seen as offering guidance to engineers, operators and other users who will continue to exercise judgement and skill in the fulfilment of their obligations. It shall be borne in mind that practice may need changes with emerging technology and experience. The requirements listed in this document shall not be regarded as a set of rigid rules that cannot be changed. It is expected that the document will be reviewed and updated as required.

SECTION 1 INTERPRETATION OF TERMS

Aboveground tank - A bulk tank which is located above ground level and not covered by sand or earth.

Bulk tank - A receptacle for storing LPG with a water capacity of more than 450 litres.

Competent person - A person who is competent by virtue of his/her training and substantial practical experience to perform/supervise/inspect/certify LPG installation, testing, and maintenance work (see Appendix B1 or B2).

Note : The list of competent persons is obtainable from the Gas Standards Office and any registered gas supply companies supplying LPG.

Cylinder - A portable receptacle for storing LPG with a water capacity of not more than 150 litres.

Cylinder store

Piped-cylinder store - A store containing cylinders connected together via a manifold piping system.

Standby cylinder store - A store containing unconnected cylinders for standby purpose.

Emergency shut-off valve - A shut-off valve incorporating manual or manual plus thermal means of shutting off gas supply from the LPG compound in an emergency.

Excess-flow valve - A device designed to close when the liquid or vapour passing through it exceeds a prescribed flow rate .

Flameproof enclosure - A type of protection in which the parts, which can ignite an explosive atmosphere, are placed in an enclosure which can withstand the pressure developed during an internal explosion of an explosive mixture, and which prevents the transmission of the explosion to the explosive atmosphere surrounding the enclosure.

Gas Authority - The authority appointed under Section 5 of the Gas Safety Ordinance (Cap. 51).

Gas Standards Office (GasSO) - An office within government which is under the control of the Gas Authority to administer the Gas Safety Ordinance (Cap. 51).

Hazardous area - An area in which an explosive gas atmosphere is, or may be expected to be, present in quantities such as to require special precautions for the construction, installation and use of electrical apparatus.

Hot work - Welding or the use of any flame or electric arc or the use of any equipment likely to cause heat, flame or spark. It also includes caulking, chipping, drilling, rivetting and any other heat producing operation, unless it is carried out in such a way as keep the temperature of the tools and work below 100°C.

Installation boundary – Boundary of LPG compound or cylinder store.

Intrinsically safe - Confining electrical energy to the installed system so that a hazardous environment cannot be ignited; and protecting the integrity of the circuit from intrusion of energy from other electrical sources so that the safe energy limitation in the circuit is not exceeded, even when breaking, shorting or earthing of the circuit occurs.

LPG - Liquefied petroleum gas as defined under the Gas Safety Ordinance (Cap. 51).

LPG compound - A bulk LPG storage installation with bulk tanks or mini-tanks as receptacles, including vaporisers, pressure regulators, piping systems and tanker bay.

Manifold system - A system consisting mainly of steel pipework and flexible gas tubing with change-over devices for connecting cylinders in transferring LPG either in liquid phase through vaporisers or in vapour phase to end users.

Mini-tank - A receptacle for storing LPG with a water capacity of more than 150 litres but not more than 450 litres.

Mounded tank - A bulk tank which is located above ground level and covered with sand or earth.

Notifiable gas installation (NGI) - An installation, as defined in the Gas Safety (Gas Supply) Regulations, including all LPG compounds, cylinder stores and vaporiser rooms.

Off-loading - Transferring LPG from road tankers to bulk tanks or mini-tanks.

Piping system - A system made up of pipes, tubings, valves and fittings, etc. for conveying LPG in either liquid or vapour state at various pressures from one point to another.

LPG pressure, high	- A pressure of more than 69 kPa
medium	- A pressure of between 6.9 kPa and 69 kPa
low	- A pressure of not more than 6.9 kPa

Note: These pressures are specific for LPG and not the same as those stipulated in the Gas Safety Ordinance.

Pressure regulator - A device which automatically controls the pressure of gas in a gas pipe.

Primary pressure regulator - A pressure regulator for reducing LPG vapour at high pressure from tanks or cylinders to medium pressure.

Secondary pressure regulator - A pressure regulator installed to receive LPG vapour at medium pressure and supply LPG at low pressure to the downstream piping system.

Pressure relief valve - A valve designed for preventing a rise of internal pressure in excess of a specified value due to emergency or abnormal conditions.

Purging - Replacing the content in a system by inert gas before putting it into or out of service.

Road tanker - A motor vehicle designed and constructed for the conveyance of LPG in bulk on roads.

Safe area (non-hazardous area) - An area in which a flammable gas mixture is not expected to be present in quantities such as to require special precautions for the construction, installation and use of electrical apparatus.

Source of ignition - Material, devices or equipment which, because of their modes of use or operation, are capable of providing sufficient thermal energy to ignite a flammable gas mixture when in contact with them.

Sterile area - A clear area that restricts planting and growth of vegetation.

Tanker bay - An area of the LPG compound where a road tanker is parked during off-loading operations.

Underground tank - A bulk tank which is located below ground level and covered with sand or earth.

Vaporiser - An equipment used to provide heat for vaporisation of LPG.

Flameproof vaporiser - A vaporiser with all electrical parts contained in a flameproof enclosure.

Water capacity - The amount of water in volumetric units at 15.6°C required to fill a container completely.

SECTION 2 OBJECTIVES AND SCOPE

2.1. Objectives

This Module has been prepared as a general outline of minimum safety standards to be followed by registered gas supply companies so as to ensure, in carrying on their business, the health and safety at work of their employees and to conduct their operations in a safe manner so that members of the public are not exposed to undue risks from gas.

2.2. Scope

2.2.1. This Module covers the design, installation, operation and maintenance of LPG compounds and cylinder stores at consumer premises. It encompasses tanks, cylinders, fittings, vaporisers, pipework, primary regulators, secondary regulators installed within the compounds or stores, off-loading facilities, electrical equipment, fire protection, site layout and fence. Maximum storage capacity is limited to 40 tonnes with a maximum bulk tank storage capacity of 20 tonnes, above which requires special consideration.

Note: *Installations described under this Module are notifiable gas installations as defined in the Gas Safety Ordinance and the construction and use of such installations shall require approval of the Gas Authority in accordance with Gas Safety (Gas Supply) Regulations 3 to 6.*

2.2.2. This Module does not cover:

- a) storage of LPG at tank farms or storage terminals;
- b) LPG-Air plants;
- c) refrigerated or partial refrigerated storage; or
- d) design and construction of cylinders.

2.2.3. The design and installation requirements in this Module shall, unless specified otherwise, apply to new installations and major alterations to NGIs only, of which the applications for construction approval are made after the effective date of this Module. The operation and maintenance requirements in this Module shall apply to all new and existing installations.

Note: *SI units shall be used for new installations. Other units are also permitted with SI unit in brackets.*

2.2.4. LPG supplied to LPG compounds and cylinder stores shall meet the following specifications:-

- a) consisting predominantly of butane and propane, and containing no harmful quantities of toxic or nauseating substances;

- b) containing no water, as ascertained by a visual examination of samples, at 15.6°C, taken from the bottom of the containers;
- c) containing not more than 0.02% (by mass) total sulphur content (see the Gas Safety (Gas Quality) Regulations), to be tested by the method described in ANSI/ASTM D2784 or similar, after a stenching agent has been added; and
- d) having a distinctive, unpleasant and non-persistent smell (irrespective of suppliers) at a dilution of 1:250 with air (approximately 20% Lower Explosive Limit), to be tested by the method described in BS 4250, or similar.

2.3. Regulations and References

- 2.3.1. All gas installation work shall comply with local statutory safety requirements. Particular reference shall be made to:

The Gas Safety Ordinance (Cap. 51)

The Gas Safety (Gas Quality) Regulations (Cap. 51)

The Gas Safety (Gas Supply) Regulations (Cap. 51)

The Gas Safety (Miscellaneous) Regulations (Cap. 51)

The Gas Safety (Registration of Gas Supply Companies) Regulations (Cap.51)

The Buildings Ordinance (Cap. 123)

The Dangerous Goods Ordinance (Cap. 295)

The Fire Services Ordinance (Cap. 95)

- 2.3.2. This Module makes reference to the following publications (latest editions of these publications shall be used as far as possible):

ANSI/ASME - American National Standards Institute/American Society of Mechanical Engineers

ASME Boiler & Pressure Vessel Code Section VIII

ANSI B16.5, Pipe Flanges and Flanged Fittings NPS ½ through NPS 24

ANSI/ASTM - American National Standards Institute/American Society for Testing & Materials

ASTM A53, Standard Specification for Pipe, Steel, Black and Hot-dipped, Zinc-coated, Welded and Seamless

ASTM D2784 – Standard Test Method for Sulphur in Liquefied Petroleum Gases (Oxy-Hydrogen Burner or Lamp)

API - American Petroleum Institute

Std. 607, Fire Test for Soft-seated Quarter-Turn Valves

AS – Standards Australia

AS 1210, Pressure vessels

BSI - British Standards Institution

BS 476, Fire tests on building materials & structures

BS 1387, Specification for screwed and socketed steel tubes and tubulars and for plain end steel tubes suitable for welding or for screwing to BS 21 pipe threads

BS 1560, Steel pipe flanges and flanged fittings (nominal sizes half an inch to 24 inch) for the petroleum industry

BS 1600, Specification for dimensions of steel pipe for the petroleum industry

BS 1965, Specification for butt-welding pipe fittings for pressure purposes

BS EN 1563, Founding – Spheroidal graphite cast irons

BS EN 1564, Founding – Austempered ductile cast irons

BS 2871, Specification for copper and copper alloys. Tubes.

BS 3601, Specification for carbon steel pipes and tubes with specified room temperature properties for pressure purposes

BS 3605, Austenitic stainless steel pipes and tubes for pressure purpose

BS 3799, Specification for steel pipe fittings, screwed and socket welding for the petroleum industry

BS 4250, Specification for commercial butane and propane

BS 4882, Specification for bolting for flanges and pressure containing purposes

BS 5345, Code of practice for the selection, installation and maintenance of electrical apparatus for use in potentially explosive atmospheres (other than mining applications or explosive processing and manufacture)

BS 5500, Specification for unfired fusion welded pressure vessels

BS 6755, Testing of valves

CGA -Canadian Gas Association

CAN/CGA B149.2, Propane Installation Code

OCC-1, Recommended practice for the control of external corrosion on buried or submerged metallic piping systems

IP - Institute of Petroleum

Model Code of Safe Practice for the Petroleum Industry Part 1 - Electrical Safety Code

LPGA - Liquefied Petroleum Gas Association, UK (formerly LPGITA - Liquefied Petroleum Gas Industry Technical Association)

No.1 Part 1, Design, installation and maintenance of bulk storage at fixed installations

No.7, Storage of full and empty LPG cylinders and cartridges

No.17, Purging LPG vessels and systems

No.22, LPG piping system - design and installation

NACE - National Association of Corrosion Engineers

RP 0169, Control of External Corrosion on Underground or Submerged Metallic Piping Systems

RP 0285, Corrosion Control of Underground Storage Tank Systems by Cathodic Protection

NFPA - National Fire Protection Association

NFPA 58, Liquefied Petroleum Gas Code

ABSI/NFPA 251, Standard Methods of Tests of Fire Endurance of Building Construction and Materials

SECTION 3 PLANT LOCATION AND SAFETY REQUIREMENTS

Note: *This Section shall be read in conjunction with "Practice Note for Authorised Persons and Registered Structural Engineers for Gas Supply Installations" issued by the Buildings Department (see the extract in Appendix C).*

3.1. LPG Compounds

3.1.1. General Requirements

- 3.1.1.1. Sites for LPG compounds shall be located to provide suitable distances away from habitable areas as the orientation of the property allows. In addition, they shall be situated in locations which are well ventilated and which, so far as can be reasonably foreseen, will remain so, even on subsequent development of adjacent sites.
- 3.1.1.2. LPG compounds shall be easily accessible for operation, maintenance, fire fighting purposes and replenishment of LPG (see Gas Safety (Gas Supply) Regulation 11(b)) but inaccessible to the public or other unauthorised persons.
- 3.1.1.3. LPG compounds shall be designed to facilitate gas dispersion in the event of LPG releases and to minimise, so far as is practicable, the risk of escaped LPG from being ignited before being dispersed or diluted (see Gas Safety (Gas Supply) Regulation 11(c)).
- 3.1.1.4. The grading of an LPG compound shall be such that LPG spillage will not collect beneath a parked road tanker.
- 3.1.1.5. The storage capacity of the compound shall have sufficient reserve so that in the event of a disruption to the normal replenishment schedule, the storage is capable of providing continuity of gas supply.

Note: *The storage of LPG should normally have an aggregate capacity of four times the average foreseeable daily demand. Higher stock may be considered especially at remote sites where replenishment is a problem.*

- 3.1.1.6. Consideration should be given to install more than one bulk tank, where appropriate, to facilitate future tank maintenance/revalidation.
- 3.1.1.7. The site selection for an LPG compound shall be determined by a risk assessment study acceptable to the Gas Authority.
- 3.1.1.8. Vehicular loading above underground bulk tank(s) should be avoided.

3.1.2. Site Fence

- 3.1.2.1. Site fence shall be at least 1.8 m high and be as open as possible, without negating the security purpose to allow for cross-ventilation of the site.

- 3.1.2.2. Major components (bulk tanks, tanker bay, piping, vaporisers) shall be enclosed within the LPG compound. Where this is not possible in case of the industrial premises, these shall be within the lot boundary.
- 3.1.2.3. Site fence around LPG compounds shall have a minimum of 2 exits located as far apart as possible from each other. One exit may be the main gate while the second exit needs only be large enough for a person to exit. The gates at exits shall not be self-locking and shall open outwards to provide for easy exit from the site. The second exit shall be locked from inside.
- 3.1.2.4. Components in locations that can be damaged by vehicular movements including those inside the site shall be suitably protected by devices such as crash barriers, bumper posts and/or concrete curbs. The safety devices shall not impair the ventilation of the site.
- 3.1.2.5. Site fence shall be bunded to a height of 150 mm to contain small spillage. A "speed-bump" at the road tanker entrance shall be integrated with the bunded fence.
- 3.1.2.6. Warning signs and emergency instructions in both English and Chinese shall be posted near each entrance on the outside wall/fence of the installation. The size of letters/characters of the warning signs, e.g. "NO SMOKING", "LPG HIGHLY FLAMMABLE" and "LPG STORE", shall be of 120 mm minimum in height.
- 3.1.2.7. The main control valve shall be suitably identified with label and positioned in such a location to enable easy access in the event of an emergency. The valve shall be accessible from outside the site fence and shall have some means of preventing unauthorised operation.
- 3.1.2.8. A sterile area of at least 1 m shall be provided and paved with concrete around the LPG compound and should be conspicuously marked with yellow lines on the floor.
- 3.1.3. Bulk Tank Location**
- 3.1.3.1. Bulk tanks shall be either underground or mounded and set inside individual vessel chambers sealed against the ingress of water, with separation distances in accordance with the diagram in Appendix D.
- 3.1.3.2. Bulk tanks (underground or mounded) shall not be installed closer than 7 m to any vessel or bund wall of vessels containing other flammable liquid with a flash point below 65°C.
- 3.1.3.3. The use of basements or pits for bulk tank location shall not be allowed.
- 3.1.3.4. The distance from the valve assembly on the manhole cover and the loading/unloading point of the LPG compound to the installation boundary where the general public have legitimate access shall be at least 3 m.

3.1.3.5. The distance between the bulk tank and the installation boundary shall be at least 1.5 m and the vessel chamber around the bulk tank shall be wholly within the installation boundary.

3.1.3.6. The distance from the valve assembly on the manhole cover, and loading/unloading point of the LPG compound to the lot boundary or fixed point of ignition shall be at least 7.6 m.

3.1.4. Tanker Bay

3.1.4.1. Tanker bay shall be in a designated area with no public access.

3.1.4.2. The surface of tanker bay shall be graded as such to prevent collection of water.

3.1.4.3. Tanker bay shall be designed for effective draining of rain and fire fighting water. If the drainage system connects to a public drain, there shall be an LPG trap incorporated into the design to prevent any LPG releases from entering the public drains. See Appendix E for typical design for an LPG trap.

3.1.4.4. Any open block and/or chain link fence enclosing the entire site shall be sufficiently open to allow for dispersion of any small LPG releases.

3.1.4.5. Crash barriers shall not be able to contain dispersion of LPG vapour in the event of a release unless they are intended as an integral structure for containment.

3.1.5. Fill-connection

3.1.5.1. Fill-connection should be as close to the bulk tank as practicable but not be located inside the valve chamber. It shall be positioned in such a way to prevent unnecessary bending of the delivery hose.

3.1.5.2. Where more than one bulk tank is installed, the liquid filling line and the vapour return line of each bulk tank, if provided, shall be separated by valves in the piping system to enable isolation of each bulk tank during operations.

3.1.5.3. Extended fill-connections shall be within the LPG compound or within the lot boundary in case of the industrial premises.

3.1.5.4. Extended fill-connections shall be protected against the possibility of mechanical damage by road tankers. Concrete posts, precast concrete curbs or similar barriers shall be used wherever exposure to damage is possible. Fill-connections shall be positioned away from the backing direction of road tankers.

3.1.5.5. Drive-away protection shall be provided in accordance with Gas Safety (Gas Supply) Regulation 40.

3.2. Cylinder Stores

3.2.1. General Requirements

3.2.1.1. Cylinder stores shall be located in a well-ventilated area and shall be easily accessible for replacement of cylinders and emergency services (see Gas Safety (Gas Supply) Regulations 11(a) and (b)).

3.2.1.2. Requirements of Sections 3.1.1.3 and 3.1.1.5 shall also be complied with.

3.2.1.3. The maximum capacity of a piped-cylinder store shall be 1000 kg. LPG cylinders are considered to be full irrespective of the state of their contents.

Note: *Standby cylinder stores could be considered, especially at remote sites where replenishment may encounter problems.*

3.2.1.4. Warning signs and emergency instructions shall be referred to Section 3.1.2.6.

3.2.1.5. A sterile area of at least 1 m shall be provided around the cylinder store and should be conspicuously marked on the floor with yellow lines.

3.2.1.6. Only one LPG store shall be constructed within a lot boundary except for remote sites or sites of a large lot where one store serving the same site is not practicable.

3.2.1.7. Drains shall be avoided in the floor area or in the immediate vicinity of the cylinder store, i.e. within 3 m of the cylinder store (or 2 m in the case of storage below 400 kg.). Where a gully or drain is unavoidable within this distance, the opening shall either be securely covered or the drain suitably sealed.

3.2.1.8. Cylinder stores shall be readily accessible at ground level and never below it in cellars or in basements. The floor of the stores shall be level, free from depressions and paved with concrete.

3.2.1.9. The storage arrangement of cylinders in standby cylinder stores shall conform to the following :-

- a) The gangway between palletised stacks shall be not less than 2.5 m.
- b) The gangway between unpalletised stacks shall be not less than 1.5 m.
- c) The maximum height of a stack shall not exceed 1.6 m.

3.2.1.10. Normally, no electrical apparatus shall be installed within the cylinder store or outside within the horizontal distances in Table 3.1; however, if electrical apparatus is required within this area, the requirements of Section 6 must be adhered to.

3.2.1.11. Cylinder stores shall be separated from other buildings or boundary by separation distances in Table 3.1 or by an imperforated wall of not less than 2 hours fire resistance period for storage in building.

3.2.1.12. Access to storage area shall be properly controlled. Cylinder stores shall be enclosed by walls or an industrial type fence not less than 1.8 m high unless it is

otherwise adequately protected (e.g. within a greater fenced area). The fence shall have at least two exits not adjacent to one another if the escape travel distance from any part of the cylinder store to the exit is more than 12m around the cylinder. Gates/doors shall open outwards so as not to impede the escape route; they shall not be self-locking and they shall provide easy means of escape from within at all times.

- 3.2.1.13. Piped-cylinder stores shall be provided with a roof constructed from non-combustible materials.
- 3.2.1.14. Cylinder stores shall be used to store LPG cylinders only, and shall be segregated by suitable separation distances away from other hazardous stores e.g. as follows :
- | | |
|---|-------|
| a) Compressed gas cylinders (except fire extinguishers) | 3 m |
| b) Acetylene cylinders | 3 m |
| c) Tanks containing flammable liquids | 3 m |
| d) Toxic, corrosive, or flammable substances | 3 m |
| e) Liquid oxygen | 7.5 m |
- 3.2.1.15. The floor of a cylinder store shall be level, or slope towards the ventilated external wall. Store entrance shall be provided with a ramp if necessary.
- 3.2.1.16. Cylinder store in building shall be of robust construction and separated from the rest of the building (except vaporiser room) by imperforated walls, ceilings, floors, etc. of not less than 2 hours fire resistance period.
- 3.2.1.17. Cylinder store in building which includes residential accommodation is not recommended.
- 3.2.1.18. The minimum separation distance from any aperture of cylinder stores to any nearest aperture of buildings (except LPG store itself and vaporiser room), or to the boundary (except where this is an imperforated wall of at least as high as the aperture and having at least 2 hours fire resistance period), or to any fixed source of ignition, or to smoking area or vehicle parking areas (except LPG cylinder wagon), shall be 1m for storage quantity up to 400 kg or 3m for storage quantity of 400-1000 kg. In case a wall full of openings (i.e. a wall having at least 80 % of its area opened for effective ventilation at all levels) is used as physical separation between the cylinders and the public, the distance could be measured from the cylinder.
- 3.2.1.19. Cylinder stores shall be constructed with ventilation and explosion relief in accordance with the requirements in Section 4.8.
- 3.2.1.20. Building walls of a cylinder store may be built on the boundary provided that they are imperforated and have a fire resistance period of not less than 2 hours.

3.2.1.21. The ventilated exterior wall of a piped-cylinder store must not be situated at the lot boundary facing directly to a public pavement. Ventilated apertures shall be located in accordance with the separation requirements of Section 3.2.1.18.

3.2.2. Radiation Walls

3.2.2.1. Radiation walls may permit separation distances to be reduced.

3.2.2.2. Radiation walls shall be imperforated, and substantially constructed of brick, concrete, or such other material, and have a fire resistance period of not less than 2 hours in accordance with BS 476 or NFPA 251 or their equivalent.

3.2.2.3. The height of radiation walls shall be at least as high as the highest stack of LPG cylinders and shall be of such a width that the distance from the cylinder store to the boundary, building or fixed ignition source measured around the end of the wall is not less than the separation distance specified in Table 3.1.

3.2.2.4. For a cylinder store without a roof and the radiation wall is a building wall, the following additional requirements shall be met :-

- a) There shall be no openings in the wall above the LPG cylinders up to a height of 9 m or within 2 m horizontally.
- b) There shall be no overhanging eaves or similar projections constructed from combustible materials above any stored cylinders. No external stairway or fire escape shall be positioned above and around the LPG cylinders.

3.2.2.5. A radiation wall may be built on a boundary, but in such a case, it shall be wholly under the control of the owner of the cylinder store.

3.3. Vaporiser Location

3.3.1. Only flameproof vaporisers shall be used for new installations and shall not be installed closer than 1.5m from any LPG bulk tank or cylinder.

3.3.2. The distance between vaporisers and the nearest building or boundary line of adjoining property shall be 3m minimum.

3.3.3. Relevant location requirements shall be in accordance with Section 3.2.1.

3.3.4. Warning sign such as "LPG VAPORISER ROOM" in both English and Chinese shall be posted at the outside wall of the vaporiser room, and the size of the letters/characters shall be of 120 mm minimum in height.

3.3.5. Where a vaporiser room is installed or attached to other buildings, the following requirements shall be complied with :-

- a) The vaporiser room is located at ground level.
- b) The vaporiser room is of single storey construction.

3.3.6. Where a vaporiser room is installed within a building, the following requirements shall be complied with :-

- a) The building is used exclusively for industrial and/or commercial use.
- b) The vaporiser room is located on the ground floor, the floor is not located below the surrounding level and the building in which the room is located does not have a basement or unventilated crawl space.

Table 3.1
Minimum Separation Distances for Cylinder Stores

Installation capacity	(1)	(2)
Up to 400 kg	1 m	Nil
400 – 1000 kg	3 m	1 m

- (1) Minimum separation distance from lot boundary/building or fixed ignition source to the nearest cylinder (where no radiation wall is provided)
- (2) Minimum separation distance from lot boundary/building or fixed ignition source to the radiation wall (where provided, details as per Section 3.2.2)

Note: *Larger standby cylinder storage quantities with greater separation distances may be considered especially at remote sites where delivery is a problem.*

SECTION 4 DESIGN

4.1. General Requirements

4.1.1. Equipment and Materials

- 4.1.1.1. All equipment used on LPG installations shall be in accordance with specified recognised standards and be suitable for LPG service.
- 4.1.1.2. All electrical equipment shall indicate clearly the type of service for which the equipment is designed, i.e. intrinsically safe or flameproof, etc.
- 4.1.1.3. All safety equipment (e.g. remote-control emergency shut-off valves, pressure and temperature sensing devices, fusible links, etc.) shall be appropriate for their intended use.
- 4.1.1.4. Cast-iron equipment and components shall not be used for LPG installations. Other materials such as bronze, brass, copper, etc. that are confirmed as suitable for LPG service may be used.
- 4.1.1.5. All rubber components shall be of a grade and quality suitable for LPG service.
- 4.1.1.6. Pressure-containing parts shall be made of steel, nodular iron, malleable iron or brass. Where nodular iron is used, it shall be in accordance with BS EN 1563 or and BS EN 1564 or equivalent. Internal parts and components shall be corrosion resistant.

4.1.2. Drawings and Records

- 4.1.2.1. Records of an LPG installation detailing equipment inventory shall be kept and updated for the service life of the installation.
- 4.1.2.2. A copy of updated site layout plan and schematic diagram of LPG compounds or piped-cylinder stores shall be kept on site for operation and emergency uses. For typical schematic diagrams, see Appendix F & G.

4.2. Bulk Tanks

4.2.1. Design and General Requirements

- 4.2.1.1. Bulk tanks shall be designed and constructed in accordance with BS 5500 or equivalent, such as AS 1210 or ANSI/ASME Boiler & Pressure Vessel Code Section VIII.

Note: *Types of bulk tanks to be used shall require approval of the Gas Authority in accordance with Gas Safety (Gas Supply) Regulation 7*

- 4.2.1.2. Bulk tanks shall be post-weld heat treated in accordance with the respective codes for the bulk tanks and shall be subject to 100% radiography examination and a satisfactory 'Charpy' test at minimum design temperature.
- 4.2.1.3. The use of partial standards shall not be allowed.

- 4.2.1.4. The steel used in bulk tanks shall be certified by the manufacturer as satisfying the design code for LPG service.
- 4.2.1.5. Bulk tanks shall be designed to a minimum pressure of 1.725 MPa and a minimum design temperature of -10°C.
- 4.2.1.6. Bulk tanks shall be provided with a minimum of 1 mm additional wall thickness for corrosion allowance.
- 4.2.1.7. An information plate shall be securely fixed to the bulk tank at a clearly visible location which shall contain the following information:
- a) manufacturer and serial number;
 - b) date of manufacture;
 - c) design code;
 - d) water capacity in kilolitres;
 - e) maximum working pressure in kPa;
 - f) design temperature range in degree centigrade - minimum and maximum;
 - g) the test pressure and date of test; and
 - h) marking of inspecting authority.

Sufficient space shall be provided to mark subsequent retest dates.

- 4.2.1.8. Records of bulk tanks shall be kept and updated for the service life of the bulk tanks and shall include the following:
- a) detailed design drawings including nozzle arrangements and fittings;
 - b) steel plate mill certificates;
 - c) weld test reports;
 - d) welder's certificates;
 - e) manufacturer's certificate of compliance; and
 - f) all test and inspection certificates.
- 4.2.1.9. Each bulk tank shall be provided with the following valves and fittings which shall be identified with suitable labels :

- a) pressure relief valve(s);
- b) shut-off valve and excess flow valve for liquid withdrawal;
- c) shut-off valve and excess flow valve for vapour withdrawal;
- d) shut-off valve and check valve for fill-connection;
- e) fixed level device connected with pressure gauge;
- f) content gauge; and
- g) plugged shut-off valve for drain connection.

4.2.2. Vessel Chamber

- 4.2.2.1. Each bulk tank shall be installed in an individual vessel chamber filled with washed sand. The location of the vessel chamber should avoid the possibility of vehicular loading. Where necessary, the top of the chamber shall be designed to withstand the weight of vehicles.
- 4.2.2.2. A clearance between the bulk tank and walls of the vessel chamber shall be required for access to the bulk tank for external inspection and renewal of anodes. The clearance shall be of a 150 mm minimum but preferably 450 mm. Bottom clearance shall be provided depending on the size of the anode but shall be not less than 200 mm.
- 4.2.2.3. Where the bulk tank is located without vehicular loading, it shall be covered with dry sand of a depth of 150 mm minimum and reinforced concrete of 100 mm minimum in thickness. Where the bulk tank is subject to vehicular loading, it shall be covered with dry sand of a depth of 450 mm minimum and reinforced concrete of 150 mm minimum in thickness.
- 4.2.2.4. The walls of the vessel chamber shall be imperforated and have a thickness of 200 mm minimum except where common chamber walls are constructed for multi-tank installations when the common walls shall be of 300 mm minimum in thickness.
- 4.2.2.5. The vessel chamber shall be properly sealed to prevent ingress of water.
- 4.2.2.6. Chamber vent pipes shall be provided diagonally in each vessel chamber to allow for periodic checks on LPG leakage and ingress of water. The vent pipe shall be extended to a point below the bottom level of the bulk tank.
- 4.2.2.7. Chamber vent pipes shall be straight and shall have a nominal bore of 20 mm minimum. Each vent pipe shall be protruded from the ground and provided with a rain cap to prevent ingress of water.

4.2.3. Supports

- 4.2.3.1. Bulk tanks shall be provided with steel saddles for mounting the bulk tanks on concrete footings.

- 4.2.3.2. The foundation and footings for each bulk tank shall be designed to support the total load of the bulk tank when filled with water,
- 4.2.3.3. Bulk tanks shall be securely anchored to prevent floating if flooded.
- 4.2.3.4. Bulk tank supports shall be designed to provide sufficient clearance for operating bottom drain connections if applicable.

4.2.4. Corrosion Protection

- 4.2.4.1. Exterior surface of a bulk tank shall be suitably treated by shot-blasting and be cleaned to exclude all rust, grease and dusts prior to applying surface coating.
- 4.2.4.2. Exterior surface of a bulk tank shall be covered and bonded with a corrosion resistant coating (see Gas Safety (Gas Supply) Regulation 12(1)) which shall:
 - a) provide electrical insulation between the bulk tank and the earth;
 - b) be inert, non-absorbent to moisture, of high dielectric strength and of sufficient mechanical strength to resist damage during installation; and
 - c) have sufficient flexibility to allow for any damage due to expansion or contraction of the bulk tank.
- 4.2.4.3. Each bulk tank shall be protected with a cathodic protection system with a test point for such system (see Gas Safety (Gas Supply) Regulation 12 (1)). The design and construction of the cathodic protection system shall be carried out by experienced corrosion specialists.
- 4.2.4.4. Where sacrificial anodes are employed for the cathodic protection system, they shall be provided in accordance with Sections 4.2.4.5 - 4.2.4.6.

Note: *For further details, refer to latest versions of NACE RP0169, RP0285 and CGA OCC-1.*

- 4.2.4.5. The size and number of anodes shall be designed by experienced corrosion specialists such that the anodes are capable for corrosion protection of the bulk tank before its next revalidation date.
- 4.2.4.6. The choice of anodes shall be based on the surface area of the bulk tank and the test results on the conditions (PH scale, resistivity, etc.) of the washed sand.

Note: *The surface potential of bulk tank to be protected shall be more negative than -0.85 volt with reference to a copper/copper sulphate (Cu/CuSO₄) electrode or more negative than +0.25 volt with reference to a zinc electrode.*

4.2.5. Pressure Relief Valve for Bulk Tank

- 4.2.5.1. Each bulk tank shall be fitted with pressure relief valve(s) which is set in accordance with a relevant pressure vessel code to which the bulk tank is

designed. The pressure relief valve shall have the following information stamped on the valve or on a separate metal plate securely fixed to it :-

- a) the manufacturer's identification including name and catalogue or type number; and
- b) the pressure at which the valve starts to discharge the product.

Extra space shall be provided on the valve or the metal plate for subsequent stamping of periodic retest dates.

4.2.5.2. For multi-port pressure relief valves, any provision made for isolating any relief valve for testing or servicing shall ensure that the remaining relief valves connected to the bulk tank are of the same full flow capacity.

4.2.5.3. For bulk tanks fitted with a single pressure relief valve, provision should be made for its removal for testing or servicing by means of an automatic shut-off valve, provided that the shut-off valve is retained in the fully open position by the presence of the relief valve and closes before the relief valve is completely removed. A replacement relief valve should be fitted immediately so as not to have the bulk tank left unprotected.

4.2.5.4. Pressure relief valves shall be of a direct spring loaded type or equivalent, be tamper-proof and be constructed in such a way so that breakage of any part shall not in any way lessen the relief function.

The outlet of a relief valve shall be piped individually to a safe location away from the bulk tank so as to prevent flame impingement on the bulk tank or any adjacent bulk tank, pipework or equipment. Relief valves shall be fitted with vent pipes adequately supported and having outlets at least 3 m above ground level and 2 m above the top of the bulk tank to which they are fitted. In addition, these vent pipes shall be designed for the full flow characteristics of the relief valves. Each vent pipe outlet shall be provided with a rain cap to prevent ingress of rain water.

4.2.5.5. Vent pipe outlet shall be located away from fixed source of ignition at a minimum distance of 4.5 m. Electrical fittings within this area shall be in accordance with Section 6.1.2.3.

4.2.5.6. For underground and mounded bulk tanks, the full flow capacity of the pressure relief valves shall be sized as per Table 4.1. For aboveground bulk tanks, the full flow capacity of the pressure relief valves shall be 3.33 times the valves as shown in Table 4.1.

Table 4.1
Minimum Rate of Discharge of Pressure Relief Valves
for Underground and Mounded Bulk Tanks

S (Surface), m ²	A (Air Flow), m ³ /min	S (Surface), m ²	A (Air Flow), m ³ /min
1.0	3.20	30	51.96
2.5	6.77	35	58.97
5.0	11.96	40	65.79
7.5	16.68	50	79.00
10	21.10	60	91.74
12.5	25.34	70	104.10
15	29.43	80	116.15
17.5	33.40	90	127.95
20	37.27	100	139.56
25	44.75	110	150.80

Where S (Surface) = total exterior surface of the tank in m²

A (Air Flow) = air to be allowed to escape at 15°C and atmospheric pressure in m³/min

For bulk tanks with sizes not in the Table, the following formula may be used.

$$A = 3.1965 S^{0.82}$$

4.2.6. Filling Level and Content Gauge

- 4.2.6.1. Bulk tanks shall be filled in accordance with Gas Safety (Gas Supply) Regulation 10 which states that the bulk tanks shall not be full of LPG at a temperature of 52.5°C. As a rule of thumb, bulk tanks shall not be filled more than 85% of the tank volume.
- 4.2.6.2. Each bulk tank shall be equipped with at least two gauges for indicating the quantity of content, one of which shall be of a fixed liquid level type.
- 4.2.6.3. Content gauges shall clearly indicate the amount of contents in % of the tank volume.
- 4.2.6.4. Permanent marking plate shall be provided for the maximum percentage of volumetric capacity that the bulk tank is to be filled under any circumstances.

4.2.7. Inspection Hole and Other Connections

- 4.2.7.1. Bulk tanks shall have a manhole or an inspection port for internal inspection. The manhole shall have a minimum diameter of 450 mm for bulk tanks exceeding

5,000 litres water capacity. For bulk tanks with manholes in the form of extended nozzles, the manhole diameter shall not be less than 550 mm. For underground or mounded bulk tanks, all fittings shall be accessible from aboveground level.

- 4.2.7.2. Liquid and vapour connections on bulk tanks other than those for pressure relief valves, plugged openings and those where the outlet from this connection through the bulk tank shell is not greater than 1.4 mm (No. 54 Morse Drill size), shall have fire resistant shut-off valves capable of manual operation located as close as practicable to the bulk tank.

Note: *A fire resistant valve is a valve that would substantially retain fluid under specified temperature conditions. BS 6755 and API 607 give guidelines on fire test for valves.*

- 4.2.7.3. An excess flow valve or check valve shall be installed in all liquid connections larger than 3.0 mm and 8.0 mm for vapour connections with the exception of openings for pressure relief valves. Excess flow valves shall be installed inside the tank opening to safeguard its function if the connection is broken outside the bulk tank. The normal closing flow rate of an excess flow valve shall be greater than the anticipated maximum flow rate so as to prevent premature closing.
- 4.2.7.4. The fill connection of bulk tank(s) at the point of the connection with a road tanker shall be equipped with a double check filler valve and a manual shut-off valve.
- 4.2.7.5. Bulk tanks shall be provided with a drain connection for removing sediment and water contents. The drain connection shall be fitted with a shut-off valve not more than 50 mm nominal diameter. The outlet shall be blanked or plugged.
- 4.2.7.6. Pressure gauges shall be provided and be connected to the vapour space of the bulk tank and shall be located in such a way so that the dial gauge can be read from above the ground level. Pressure gauge connections shall be protected either by a tapping reduced internally to a bleed hole not larger than 1.4 mm diameter or by a suitable excess flow valve and shut-off valve.
- 4.2.7.7. Temperature gauges, where fitted, shall be installed in blind pockets. The pockets shall be in the form of blind tubes of suitable length and strength, oil filled, permanently welded to the bulk tank and constructed in accordance with the corresponding bulk tank design code.
- 4.2.7.8. Pipework and fittings on bulk tanks shall be suitably protected against mechanical damage.

4.3. Piped-cylinder Stores

4.3.1. General

4.3.1.1. A piped-cylinder store may have cylinders supplying LPG either in liquid or gaseous form to a manifold system.

4.3.1.2. Typical schematic diagrams are shown in Appendix G.

4.3.2. Flexible Gas Tubing (Pigtail)

4.3.2.1. A pigtail connecting each cylinder to a manifold system shall not be left unconnected and be protected from direct sunlight.

4.3.2.2. Pigtails shall be manufactured according to recognised engineering standards or codes. If wire braid is used for reinforcement it shall be of corrosion resistant material such as stainless steel. Gas supply companies shall maintain records of relevant inspection and testing certificates.

4.3.2.3. Pigtails shall be designed to withstand a minimum bursting pressure of 4 times the maximum working pressure. Each pigtail shall be marked with "LPG" and be tagged with a label indicating the date of next replacement.

4.3.2.4. Each pigtail coupling shall be incorporated with a self-closing valve to prevent leakage of LPG from the pigtail during disconnection from an LPG cylinder.

4.3.3. Safety Devices

4.3.3.1. Provision shall be incorporated into a manifold system to ensure that failure of a pigtail connecting a cylinder to the manifold will not cause the complete loss of content from other cylinders.

4.3.3.2. When more than one cylinder supplying LPG to a piped gas system by means of pigtails to a manifold system, appropriate safety devices shall be incorporated in accordance with Gas Safety (Gas Supply) Regulation 11(e) as described in Section 4.3.3.3.

4.3.3.3. The device consisting of a stop valve with check function shall be installed between the pigtail and the manifold system for all cylinders. In the case of liquid withdrawal cylinders, one particular cylinder of each bank shall be installed with a stop valve with excess flow device to allow liquid LPG to flow back from the vaporiser.

4.3.4. Change-over Devices

4.3.4.1. A change-over device shall be installed for a piped-cylinder store between two banks of cylinders, one for regular supply and the other for reserve.

4.3.4.2. The operation of the change-over device shall avoid GAS ON - GAS OFF - GAS ON situation, and shall have suitable means of indication for gas flow direction.

- 4.3.4.3. By-pass pipework in addition to change-over device may be provided to ensure continuity of supply during maintenance. By-pass valves shall be kept closed throughout the normal operation.

Note: *For change-over devices with pressure regulating function, when using the by-pass pipework, the downstream regulators or equipment shall be checked to see if the supply pressure is within their design operating limits.*

4.4. Vaporisers

4.4.1. General

- 4.4.1.1. Vaporisers shall be of flameproof type.
- 4.4.1.2. Pressure containing components of vaporisers shall be designed in accordance with a recognised pressure vessel code. The design pressure for the LPG pressure containing parts shall meet the highest pressure and temperature in service.
- 4.4.1.3. Electrical wiring and lighting for vaporiser rooms shall be designed and constructed in accordance with Zone 1 Electrical Classification.
- 4.4.1.4. A metal plate securely fixed to the outside of each casing shall be permanently marked with the following information :-
- a) manufacturer and the serial number;
 - b) date of manufacture;
 - c) design code;
 - d) vaporising capacity; and
 - e) maximum working pressure & design temperature.
- Extra space shall be provided on the metal plate for subsequent periodic marking of retest dates.
- 4.4.1.5. Heating coils shall not be installed inside bulk tanks as a means of vaporisation.
- 4.4.1.6. Every liquid or vapour line fitted to a vaporiser shall be provided with a shut-off valve located as close as practicable to the vaporiser in accordance with Gas Safety (Gas Supply) Regulation 13.
- 4.4.1.7. Pressure regulating and other equipment downstream of a vaporiser shall be designed for the pressure output of the vaporiser and the maximum discharge temperature of LPG.
- 4.4.1.8. For bulk tank installation, emergency shut-off valves upstream of the vaporisers shall be installed in a prominent location outside of the vaporiser room for easy access and operation under emergency conditions. Emergency shut-off valves shall be of a fire-resistant type (see Note in Section 4.2.7.2).

4.4.1.9. Drain connection shall be provided to the vaporiser with a shut-off valve to allow for removal of heavy ends. The connection shall be blanked or plugged.

4.4.2. Pressure Relief Valve for Vaporiser

4.4.2.1. Vaporiser shall be fitted with a pressure relief valve in direct communication with the vapour space which is set to relieve in accordance with the pressure vessel code to which the vaporiser is designed and constructed. The relief capacity shall be 3.33 times the values as shown in Table 4.1, using the surface area of the vaporiser shell and that of the heat exchanger that is directly in contact with LPG as the total surface area. Valve identification shall be provided in accordance with Section 4.2.5.1.

4.4.2.2. Pressure relief valves shall be of a direct spring-loaded type or equivalent, be tamper-proof and be constructed in such a way so that breakage of any part shall not in any way lessen the relief function.

4.4.2.3. For vent pipe arrangement, see Sections 4.2.5.4 & 4.2.5.5.

4.4.3. Heat and Liquid Controls

4.4.3.1. Heat input shall be controlled by a suitable thermostat to prevent the pressure in the vaporiser from reaching the set pressure of the relief valve.

4.4.3.2. Vaporiser with water as heating medium shall be controlled by thermostat for regulating the water temperature. It shall include a means of water level indication and low water level cut-off if the water level drops below certain set level.

4.4.3.3. Large vaporiser with several heating elements may be controlled in stages by more than one thermostat for regulating the temperature.

4.4.3.4. Vaporiser shall be provided with an automatic control valve of a suitable type (e.g. thermostatic, magnetic or float) to prevent liquid LPG from passing through the vaporiser.

4.5. Pressure Regulators

4.5.1. Design Criteria

4.5.1.1. In general, a piped gas supply system shall consist of primary and secondary pressure regulators, which shall be designed in accordance with Gas Safety (Gas Supply) Regulation 21 in order to achieve the following objectives :-

- a) ensuring reliable and continuous supply of LPG;
- b) protecting downstream system against over-pressure and under-pressure; and
- c) protecting against failure of any single regulating device causing a hazardous situation.

4.5.2. Primary Pressure Regulator

- 4.5.2.1. An active and monitor regulator system with two regulators installed in series shall be provided for supplying LPG to multi-users. The upstream monitoring regulator shall be set marginally higher than that of the downstream active regulator.
- 4.5.2.2. A cascade system or parallel regulators system consisting of active and monitor pressure regulators should be considered for an installation with large LPG consumption.
- 4.5.2.3. For a single user, one regulator may be used for primary pressure regulation.
- 4.5.2.4. The normal operating pressure for a domestic distribution system after primary regulators shall be 69 kPa (10 psig) maximum.
- 4.5.2.5. Valves shall be provided in such a way so that regulators may be accessible for servicing and maintenance.
- 4.5.2.6. A vapour line with suitably sized regulators shall be installed to supply gas direct from the vapour space of the bulk tanks.
- 4.5.2.7. Provision of an additional by-pass line may be incorporated to facilitate the maintenance of primary regulators. Unless the by-pass line is properly terminated with valves and plugged, it shall be provided with a suitable size regulator with overpressure shut-off function.
- 4.5.2.8. A main control valve shall be installed on the vapour line downstream of the primary regulators for termination of gas supply to consumers in the event of an emergency (see Section 3.1.2.7).
- 4.5.2.9. Pressure gauges of suitable range shall be installed for indicating conditions of the regulators.
- 4.5.2.10. Sensing pipework required for primary regulators shall be of solid drawn copper tubes in accordance with BS 2871 or equivalent, but suitable corrosion-resistant steel tubes are acceptable provided that they are connected with suitable proprietary fittings.
- 4.5.2.11. Sensing pipework shall be routed in such a way so as to eliminate excess bending or fracture due to impact.

4.5.3. Secondary Pressure Regulator

- 4.5.3.1. Secondary regulators may be installed inside the LPG compound or piped-cylinder store.
- 4.5.3.2. Secondary regulator shall include overpressure and underpressure protections.
- 4.5.3.3. The downstream pressure from secondary regulator shall not exceed 6.9 kPa (1 psig) for supplying gas to domestic users.

4.6. Pipework and Fittings

4.6.1. General Requirements

- 4.6.1.1. Pipework should be routed in the open air and aboveground. It shall be routed away from or protected against excessive heat or cold. Pipework may be buried underground.
- 4.6.1.2. Pipework layout and supports shall provide adequate allowance to accommodate any movement that may occur due to thermal expansion or contraction of LPG pipework. Distance between pipe supports for vertical and horizontal pipe sections shall be in accordance with Table 4.2.

Table 4.2
Support Spacing for Aboveground Pipework

Nominal size (mm)	Maximum spacing	
	Vertical (m)	Horizontal (m)
20	3	2.5
25	3	2.5
32	3	2.7
40	3.5	3
50	3.5	3
80	4.5	3
100	4.5	3
150	4.5	3
200	4.5	3

- 4.6.1.3. Pipework shall be suitably protected including galvanising, painting or wrapping, and colour coded in yellow with the word "Vapour" marked on the surface of the pipework containing vapour. Pipework containing liquid LPG shall be suitably colour coded in blue with the word "Liquid" marked on the surface of the pipework.
- 4.6.1.4. Pressure gauges or plugged test points shall be provided at various strategic points of the pipework system for operational use or commissioning. Pressure gauges shall not be provided on liquid LPG pipework except pumping facilities.
- 4.6.1.5. Electrostatic precaution shall be in accordance with the requirements stated in Section 6.2.
- 4.6.1.6. Pipework passing through walls and/or floors shall be sleeved and sealed properly with suitable corrosion protection materials.

4.6.2. Materials and Construction

Note: See also *Gas Safety (Gas Supply) Regulation 17* for general statutory requirements for pipework. For the purpose of this Module, Regulations 17(1), (2), (3), (5) and (7) are relevant.

- 4.6.2.1. High pressure pipework (before primary regulator) shall be of seamless steel conforming to ASTM A53, BS 3601 or equivalent.
- 4.6.2.2. Medium pressure pipework (after primary pressure regulator) shall be of heavy grade steel conforming to BS 1387 or equivalent.
- 4.6.2.3. Low pressure pipework (after secondary pressure regulator) shall be of medium or heavy grade steel conforming to BS 1387 or equivalent.
- 4.6.2.4. Steel flanges and flanged fittings shall conform to ANSI B 16.5, BS 1560 or equivalent and bolting arrangement to BS 4882 or equivalent.
- 4.6.2.5. Use of cast-iron pipe shall not be permitted.
- 4.6.2.6. Joints for pipes above 50 mm shall be butt-welded or socket-welded. Welded connection for pipe fittings shall be in accordance with BS 1965 or equivalent.
- 4.6.2.7. Pipe joints up to and including 50 mm nominal diameter may be threaded. Threaded high pressure pipes and fittings shall be of heavy wall thickness of Schedule 80 (BS 1600 or equivalent) and be of the same tapered form. Threaded medium and low pressure pipework shall be of heavy grade steel to BS 1387 or equivalent.
- 4.6.2.8. Steel socket-welded and screwed fittings and screwed couplings shall be in accordance with BS 3799 or equivalent.

4.6.3. Hydrostatic Pressure Relief Valve

- 4.6.3.1. Hydrostatic pressure relief valve (HPRV) shall be fitted between any pipe sections where liquid LPG can be trapped (e.g. sections between shut-off valves and blank flanges, pumps between closed suction and discharge valves, etc.) in order to accommodate any thermal expansion.
- 4.6.3.2. HPRV should have a pressure rating at a range of 2.4 MPa (350 psig) to 2.75 MPa (400 psig).
- 4.6.3.3. The pressure setting of HPRV shall not be higher than the weakest element in the system.
- 4.6.3.4. The discharge outlet of HPRV shall be positioned towards ventilated areas and shall not be directed towards persons, bulk tanks or equipment.
- 4.6.3.5. HPRV shall be protected by means of rain cap.

4.6.4. Valving

- 4.6.4.1. Valves shall be installed at accessible locations for ease of operation and maintenance.
- 4.6.4.2. Manual shut-off valves fitted onto the liquid and vapour outlet connections of a bulk tank shall be of a fire-resistant type (see Section 4.2.7.2).
- 4.6.4.3. Each LPG compound or piped cylinder store shall have a main control valve for shutting off all LPG supply under emergency conditions. It shall be located at a prominent position, suitably marked, and easily accessible under emergency conditions.

4.7. Drain Connections

- 4.7.1. This Section applies to bulk tanks and vaporisers.
- 4.7.2. The outlet of the drain valves may be provided with a length of pipe terminating with a second shut-off valve. The length of pipe shall be such that the risk of simultaneous freezing of the two valves is minimised.

***Note:** This section of pipe and associated fittings need not be permanently installed to bulk tanks and vaporisers.*

- 4.7.3. The second valve and associated pipework shall be adequately supported and secured to prevent mechanical damage.
- 4.7.4. Valve control shall be securely fixed to the drain valves to ensure that the valves can be closed instantly during the draining operation.
- 4.7.5. The second valve may be fitted permanently where appropriate. In this case, the outlet of the second valve shall be blanked or plugged when not in use.
- 4.7.6. No drain shall discharge into or be in the proximity of any public or other drainage system where this would be liable to create a hazard.

4.8. Ventilation and Explosion Relief

4.8.1. General

- 4.8.1.1. The design of LPG installations (e.g. LPG compounds, cylinder stores and vaporiser rooms, etc.) shall be such that the occurrence of a build-up of an LPG /air mixture above the lower explosive limit is minimised by the provision of adequate ventilation, but should such a build up occur and ignition take place, the consequences of such an incident to the surrounding environment shall be minimised by the provision of adequate explosion relief.
- 4.8.1.2. LPG installations shall be constructed with non-combustible materials. A heavy duty wire mesh structure with a light roof for weather protection is acceptable. Where a rigid concrete structure is necessary, it shall be designed to provide maximum ventilation and explosion relief.

4.8.1.3. Walls, ceiling, roofs and doors (including door frame and hinge assembly) shall be designed such that if imperforated, they shall be capable of withstanding a static pressure of at least 4.8 kPa.

4.8.1.4. Where wire meshes are used for ventilation, they shall be of grid sizes not less than 5 mm.

4.8.2. Natural Ventilation

4.8.2.1. LPG installations shall be ventilated utilising air inlets and outlets arranged to provide air movement across the floor as uniformly as practical and in accordance with Sections 4.8.2.4 - 4.8.2.7.

4.8.2.2. Ventilation apertures shall be positioned in such a way so as to prevent accumulation of LPG.

4.8.2.3. LPG cylinders and/or equipment shall not be located within 150 mm of ventilation apertures. Suitable measures shall be taken to prevent blockage of ventilation apertures.

4.8.2.4. Apertures for ventilation shall be situated in external walls of LPG installations such that :-

- a) the bottoms of low level ventilation apertures are not more than 150 mm above the floor;
- b) the tops of high level ventilation apertures are not more than 500 mm below the ceiling;
- c) the effective low level ventilation area is within 500 mm from the floor; and
- d) the effective high level ventilation area is within 1,000 mm from the ceiling.

4.8.2.5. Where 4 walls, 3 walls or only 2 opposite walls are used for ventilation, apertures shall be provided having a total effective area of at least 0.014 m^2 per m^2 of floor area at low level and 0.007 m^2 per m^2 of floor area at high level.

4.8.2.6. Where only 2 adjacent walls are used for ventilation, apertures shall be provided having a total effective area of at least 0.02 m^2 per m^2 of floor area at low level and 0.01 m^2 per m^2 of floor area at high level.

- 4.8.2.7. A single ventilated wall may only be used for ventilation if all the following criteria are met :-
- a) The width of the ventilated wall is at least 1.5 times of the depth of the LPG installation to be ventilated.
 - b) The depth of the LPG installation to be ventilated does not exceed 2.5 m.
 - c) Apertures are provided having a total effective area of at least 0.03 m^2 per m^2 of floor area at low level and 0.015 m^2 per m^2 at high level.
- 4.8.2.8. Where all the natural ventilation criteria cannot be met, mechanical ventilation may be considered.

4.8.3. Explosion Relief

- 4.8.3.1. LPG installations shall be provided with explosion relief apertures located in external walls, the explosion relief area shall be at least 0.07 m^2 per m^3 of enclosed volume for open vents, or at least 0.1 m^2 per m^3 of enclosed volume for louvred vents. A louvred angle shall not be in excess of 45° to the horizontal. The method for calculating the “effective area of ventilation/explosion relief” is shown in Figure 4.1.
- 4.8.3.2. Imperforated explosion relief panels shall not be used.
- 4.8.3.3. Ventilation apertures may be included as explosion relief apertures.

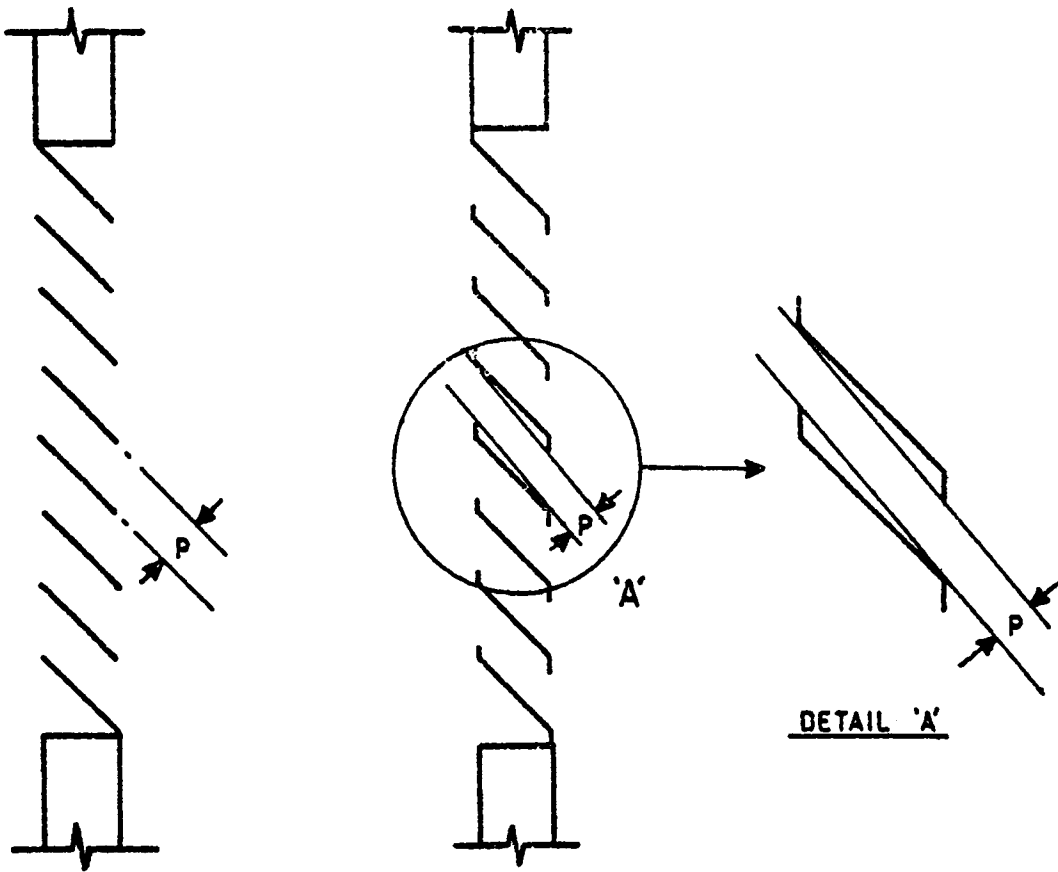

$$\text{Effective Area} = p \times n \times w$$

where p = unobstructed pitch between louvres
 n = number of louvred apertures (7 in above examples)
 w = width of louvred opening

Figure 4.1
Calculation of Effective Area for Louvres

SECTION 5 FIRE PRECAUTIONS

- 5.1. LPG storage sites shall be maintained regularly to prevent overgrown vegetation, and storage of combustible and irrelevant materials.
- 5.2. LPG compounds, cylinder stores and vaporiser rooms shall be equipped with fire extinguishers of dry powder type at suitable locations in accordance with Table 5.1.
- 5.3. Fire extinguishers shall be replaced or revalidated annually, and marked conspicuously with the last test date.
- 5.4. Provision of fire fighting facilities shall comply with the requirements of the Fire Services Department as appropriate.

Table 5.1
Minimum Number of Fire Extinguishers Required
for LPG Compound, Cylinder Store and Vaporiser Room

LPG Storage Capacity (Tonnes)	Minimum Number of Fire Extinguishers Required
LPG Compound (excluding vaporiser room)	
Up to 25	2
Above 25	3
LPG Cylinder Store (excluding vaporiser room)	
Up to 1	1
1 - 2.5	2
Above 2.5	3
Vaporiser room	1

SECTION 6 ELECTRICAL REQUIREMENTS AND ELECTROSTATIC PRECAUTIONS

6.1. Electrical Requirements

6.1.1. Hazardous Area Classification

Area classification is dependent on the probability of a hazardous atmosphere being present i.e. an atmosphere containing a significant quantity of flammable gas mixture capable of being ignited. It is defined as the following zones :-

Zone 0 - An area in which an flammable gas-air mixture is continuously present in normal operation.

Zone 1 - An area in which an flammable gas-air mixture is likely to occur in normal operation.

Zone 2 - An area in which an flammable gas-air mixture is not likely to occur in normal operation, and if it occurs it will only exist for a short time.

Non-hazardous or safe area - An area which is not classified as Zone 0, 1 or 2.

6.1.2. Electrical Equipment

6.1.2.1. Electrical equipment should, as far as possible, be located in safe or non-hazardous areas.

6.1.2.2. Electrical equipment for use in and around LPG installation (see definitions in Section 6.1.1) shall be certified with stamped markings for the intended use (i.e. appropriate classified zone, gas group and temperature classification) in accordance with BS 5345 or equivalent.

6.1.2.3. Selection and installation of electrical equipment for use in hazardous areas shall be generally in accordance with the recommendations of BS 5345 or equivalent (see Appendix H).References may also be made to the IP Code of Practice, Part 1.

6.1.2.4. Electrical equipment for use in classified zones shall be certified by approval bodies such as BASEEFA in accordance with BS 5345 or equivalent.

6.1.2.5. All electrical wiring and cables for use in classified zones shall be certified by the manufacturer as being suitable for its intended use.

6.2. Electrostatic Precautions

6.2.1.1. Underground and mounded bulk tanks and LPG pipework with cathodic protection systems should not be earthed normally, and outlet connections shall be electrically insulated from the downstream pipework by means of suitable insulation flanges.

Note: *Existing aboveground bulk tanks shall be electrically earthed to protect against accumulation of static electricity.*

- 6.2.1.2. A bonding connection should be provided and extended to equalise the potential between the road tanker and the bulk tank(s).
- 6.2.1.3. An earthing point should be provided at tanker bay for discharging static electricity from road tankers. Earthing points for dissipation of static electricity should have an electrical resistance to earth of not greater than 1×10^6 ohms.
- 6.2.1.4. Aboveground pipework and fittings downstream of the insulation flanges shall be bonded to earth.

SECTION 7 INSTALLATION

7.1. General

- 7.1.1. Construction approval from the Gas Authority shall be obtained prior to carrying out any installation work of LPG compounds or cylinder stores (see Note of Section 2.2.1).
- 7.1.2. Installation work shall be in accordance with the approved drawings and design requirements as stated in this Module.
- 7.1.3. Installation work shall be carried out by suitably trained and experienced persons.
- 7.1.4. LPG installations shall not be used to contain any LPG unless use approval is obtained from the Gas Authority, and that they are commissioned in accordance with the requirements of Section 8 (see also Note of Section 2.2.1).
- 7.1.5. Installation sites shall be suitably prepared prior to delivery of equipment and installation work.

7.2. Bulk Tanks

- 7.2.1. Each bulk tank shall be holiday and paint thickness tested (400 µm minimum) over its entire surface and any defects found shall be repaired and retested before burying the tank.
- 7.2.2. Bulk tank shall be installed on firm foundation and shall be secured at both ends against floatation.
- 7.2.3. Extreme care shall be taken when transporting and handling bulk tanks to prevent them from accidental damage to the coatings.

7.3. Vaporisers

- 7.3.1. Vaporisers shall be installed in accordance with manufacturers' instructions. Care shall be taken to ensure that vaporisers are adequately supported without undue strain on the associated pipework.
- 7.3.2. Pressure relief valves, pressure regulators and control equipment installed at/near the vaporiser shall not be located at where the ambient temperature is in excess of 60°C unless they are specifically designed for higher temperatures.
- 7.3.3. The outlet of drain valves shall be blanked or plugged when not in use.
- 7.3.4. Vaporiser shall be equipped with a pressure gauge at the vaporiser outlet. In the case of a water-heated vaporiser, a means for temperature and water level indication shall be provided accordingly.

7.3.5. The pressure relief valve of each vaporiser shall be piped upwards individually and its vent outlet shall be directed away in a safe manner from other vaporisers and/or bulk tanks. The vent pipe shall be designed and constructed for the full flow capacity of the pressure relief valve.

7.4. Pipework and Fittings

7.4.1. LPG pipework shall be of welded construction as far as practicable. Welded joints shall be fabricated in accordance with relevant design and welding standards.

Note: *LPGA Code of Practice No.22, NFPA 58, CAN/CGA B149.2 or equivalent are applicable.*

7.4.2. Shut-off valves shall be installed to enable isolation of equipment and between lengths of pipework. An HPRV shall be fitted to each liquid pipe section that can be isolated.

7.4.3. Before installation, all fittings and pipe sections shall be inspected and cleaned inside to ensure absence of dusts, grease, rust and foreign matters. During installation, precautions shall be taken to prevent pipe connections from contamination. Exposed threads after connection shall be immediately treated and coated against corrosion.

7.4.4. Before installation of pressure regulators, their dust caps, transit locking pins, etc. shall be removed, and the orientation and correct direction of flow determined. Pressure regulators shall be adequately supported and oriented in accordance with the manufacturer's instructions.

7.4.5. After installation, pipework shall be suitably treated against corrosion and be identified.

7.5. Cathodic Protection

7.5.1. Anodes shall be so placed in washed sand that they are free from any possible contact to other objects.

7.5.2. Reference electrode shall be installed and terminals provided for testing of the cathodic protection system. The end of the test wires shall be installed in a weatherproof test box at ground level and be suitably identified. When installing an earthing system, care shall be taken not to interfere with the cathodic protection system.

7.5.3. As-built drawings and records of the cathodic protection system shall be made after installation and shall include the following data :-

- a) quantity, type, size and location of anodes;
- b) date of installation;
- c) type of backfill material; and

d) resistivity measurement of electrolyte.

These records and subsequent periodic testing results shall be maintained for the service life of the bulk tank.

SECTION 8 TESTING AND COMMISSIONING

8.1. General

- 8.1.1. LPG installations shall be tested and commissioned in accordance with the appropriate standards, codes of practice, drawings, specifications, manuals, etc. Manufacturer reports/catalogues for bulk tanks, vaporisers and equipment, etc. shall also be checked accordingly.
- 8.1.2. Cathodic protection, earthing, electrical continuity and static bonding arrangements shall be tested in accordance with appropriate standards.
- 8.1.3. Relevant tests on bulk tanks, vaporisers and associated piping system shall be supervised and certified by a competent person (See Appendix I1, I2 or I3).
- 8.1.4. All test records and certificates should be maintained for the service life of the system.
- 8.1.5. All purging and commissioning work shall be carried out by suitably trained persons.
- 8.1.6. Appropriate personal protective clothing and safety equipment including flammable gas detectors shall be used by people involved with LPG work.
- 8.1.7. Fire fighting equipment shall be made available during purging and commissioning work.

8.2. Bulk Tank and Vaporiser Testing

- 8.2.1. The following tests shall be required for bulk tanks:-
 - a) hydraulic test;
 - b) ultrasonic thickness test ;
 - c) radiography test (for new tank only);
 - d) magnetic particle test;
 - e) paint thickness test; and
 - f) holiday test.
- 8.2.2. Bulk tanks and vaporisers shall be hydraulically tested at 1.5 times of their design pressure, i.e. 2584 kPa (375 psig) for integrity, unless otherwise specified by their respective design code.

8.2.3. All connections of bulk tanks, vaporisers and associated fittings shall be leak tested to a minimum pressure of 689 kPa (100 psig) by air or inert gas (check joints with soap solution).

8.2.4. After leak test, the system shall be purged into service as per Section 8.4.

8.3. Pipework Testing

8.3.1. All pipework shall be tested after construction and before being placed in operation to ensure that it is structurally sound and gas-tight. In carrying out the test, precautions shall be taken to protect :-

- a) the person carrying out the test;
- b) any persons working in the vicinity; and
- c) members of the public,

against any dangers which may arise if such pipe fails the test.

8.3.2. All pipework shall be pressure tested as follows :-

- a) All liquid lines shall be hydraulically tested at 1.1 times the HPRV setting (see Section 4.6.3), after isolation of elements that could be damaged by the test pressure. Pressure test certificates shall state HPRV setting in addition to hydraulic test pressure.

After the hydraulic test is completed, all isolated elements shall be properly installed and the whole system shall be tested pneumatically at a minimum pressure of 689 kPa (100 psig).

- b) High pressure vapour lines shall be tested either pneumatically or hydraulically at a minimum pressure of 1034 kPa (150 psig).

Note: *The test pressure is based on 1.5 times the maximum working pressure. The maximum working pressure taken as the vapour pressure of LPG at 37.8°C is generally within the range of 517 - 689 kPa (75 - 100 psig). The test pressure at 1034 kPa minimum shall have adequate coverage.*

- c) Medium and low pressure vapour lines shall be tested either pneumatically or hydraulically at a minimum pressure of 103 kPa (15 psig) and 69 kPa (10 psig) respectively.

8.3.3. Time shall be allowed for temperature stabilisation during pressure testing. The line pressure shall be adjusted to the test pressure after stabilisation.

Note: *The time allowing for temperature stabilisation depends on the ambient temperature, test medium, pipe size and length. Generally this shall not be less than 15 minutes.*

8.3.4. For pneumatic testing, the test shall be undertaken in phases as follows :-

- a) Initially pressurise the system to 140 kPa (20 psig) and hold it for sufficient time to ensure that all fittings have been adequately fastened.
- b) The pressure shall then be raised in stages until the required test pressure is reached.
- c) After each pressure increase, sufficient time shall be allowed to ensure system integrity.

8.3.5. For hydraulic and pneumatic pressure test, the test period shall be of a minimum of 30 minutes and there shall be no sign of pressure decay during this period. Care should be taken of the pipework which may suddenly rupture due to the pressure test.

Note: *Pressure decay indicates leakage and leaks shall then be identified by sight and sound or soap solution.*

8.3.6. All open ends of a piping system shall be suitably blanked before testing.

8.3.7. Pipework pressure tests shall be recorded and the test report shall include the following:

- a) name of contractor, and signature of the competent person who supervised the tests;
- b) test date;
- c) maximum working pressure;
- d) test pressure, medium and duration;
- e) test results; and
- f) material, rating and specification of pipework and fittings.

8.3.8. The pressure of the pipework shall be reduced to zero as soon as is practicable after the pressure tests (see Gas Safety (Gas Supply) Regulation 20). Upon satisfactory completion of pressure tests, the pipework shall be purged into service in accordance with Section 8.4 prior to commissioning and operation of the LPG installation.

8.4. Purging into Service

8.4.1. The procedure of purging into service of bulk tanks is as follows (pressure and vent method) :-

- a) After pressure testing of a bulk tank, inert gas (e.g. N₂) is added to the bulk tank until the O₂ content is below 11.4%.

Note: *If the medium of pressure test is inert gas, this procedure is not necessary as long as the inert gas is maintained above atmospheric pressure within the bulk tank.*

- b) Small traces of water may be removed by spraying a small quantity of methanol into the bulk tank.
- c) To prevent rapid vaporisation of LPG liquid, only vapour LPG shall be admitted into the bulk tank until the tank pressure is close to the supply pressure.
- d) Before the flaring process, the Fire Services Department should be informed.
- e) A flare stack with a permanent pilot, located in a safe area, shall be connected to a suitable vapour connection for flaring of the LPG/inert gas. Care shall be taken to ensure complete removal of the inert gas (a stable flame at the flare stack) before terminating the flaring process.
- f) Introduce vapour LPG into the tank until the tank pressure reaches the vapour pressure of the LPG in the delivery tank.
- g) The tank shall be replenished according to Section 9.2.

Note: *While flaring is in process, the road tanker shall not be in the LPG compound.*

8.4.2. The procedure for purging into service of pipework (including vaporisers and associated equipment) is as follows (ram purge method) :-

- a) Before introducing LPG into the pipework, it shall be purged with inert gas (e.g. N₂) so that oxygen is reduced to a level of less than 11.4% by volume. Inert gas shall be introduced in a controlled manner by adjusting the pressure regulator.
- b) Before putting liquid LPG into the liquid pipework, vapour LPG shall be introduced into the pipework up to the delivery tank pressure in order to avoid sudden chilling of the pipework.
- c) For pipework sizes up to 32 mm nominal bore, LPG/inert gas mixture may be dispersed under proper supervision to a well ventilated area without any source of ignition. For pipework sizes above 32 mm nominal bore, a flare stack with permanent pilot shall be used and is located at a safe distance away from the bulk tanks and other vulnerable structures.
- d) Care shall be taken to ensure removal of the inert gas (a stable flame at the flaring stack) before terminating the flaring process.

8.5. Purging out of Service

- 8.5.1. The procedure for purging out of service of an LPG installation using inert gas is as follows :-
- a) LPG in a bulk tank shall be depleted as far as practicable through normal consumption or decanted to a road tanker prior to purging.
 - b) The bulk tank to be purged shall be properly isolated and blanked off from other tanks and/or pipework.
 - c) A flare stack with a permanent pilot, located in a safe area, shall be connected to a suitable vapour connection of the tank for flaring of the residual LPG.
 - d) The flaring process shall be attended to at all times during purging.
 - e) Inert gas (e.g. N₂) shall be introduced into the top of the bulk tank. Care shall be taken by means of a combustible gas detector to ensure complete removal of LPG before terminating the flaring process. In this case, the LPG content of the purged gas mixture shall be less than 5%.
 - f) Once the bulk tank is at atmospheric pressure, the manhole cover may then be removed and air be introduced into the tank.
 - g) No one shall enter into the tank until the internal atmosphere has been verified to be safe (LPG level less than 5% of the lower explosive limit and oxygen level not less than 18%). Detector probes shall be used to ensure that LPG is not present at the bottom of the tank and oxygen level is adequate inside every part of the tank.

8.5.2. Water can be used as a medium for purging instead of inert gas. The procedure shall be the same as per Section 8.5.1 except that water is introduced into the bottom of the bulk tank.

8.6. Commissioning

- 8.6.1. All equipment, joints and valves, etc. shall be checked for leakage, integrity and proper function before commissioning.
- 8.6.2. Pressure regulators shall be set to their lowest outlet pressures initially and gradually adjusted to their required operating pressures. The regulators shall be checked for their pressure control function over the entire range of the design conditions including shut-off capability.
- 8.6.3. LPG trap shall be checked to ensure that it is topped with water (see Appendix E).
- 8.6.4. Active and monitor regulators shall be set during commissioning for the designed function in case of active regulator failure.
- 8.6.5. Vaporisers including their heat and level controls shall be checked for their satisfactory operation.

- 8.6.6. The operation of water drenching systems (including automatic actuating systems and alarms), where fitted, shall be checked for its satisfactory performance before putting the LPG installation into operation.

SECTION 9 OPERATION

9.1. General

9.1.1. Operating instructions shall be in place to ensure safe, continuing and reliable operation of the installation in supplying gas to consumers.

9.1.2. Persons engaged in LPG operation shall :-

- a) be provided with extensive training in their specific areas of responsibilities;
- b) be thoroughly familiar with the properties of LPG;
- c) have knowledge of and access to the appropriate codes of practice at all times;
- d) have specific guidance on the instructions to be followed under emergency conditions;
- e) be familiar with different types of fire fighting and fire control equipment, including fire extinguishers;
- f) ensure that the LPG storage does not exceed its approved quantities; and
- g) ensure that all fire extinguishers are clearly identified for their types and expiry dates.

9.2. Replenishment of LPG Tanks

9.2.1. Off-loading of LPG shall be carried out by at least 2 competent road tanker operators (see Gas Safety (Gas Supply) Regulation 39), one of whom may be the road tanker driver.

Note: *In the case of extended fill-connection, the driver shall stay close to the road tanker to monitor off-loading while his assistant shall monitor the filling in progress at the LPG tank.*

9.2.2. Persons engaged in off-loading of LPG shall be suitably trained in first aid, fire fighting and emergency response.

9.2.3. Persons engaged in off-loading of LPG shall wear suitable protective clothing to avoid frostbite, which can occur if LPG comes in contact with unprotected skin.

9.2.4. A reporting procedure shall be instituted to record every accidental LPG release, equipment failure or personal injury that may occur during the off-loading operation.

9.2.5. The road tanker shall be parked in a designated tanker bay.

9.2.6. The following precautionary measures shall be observed throughout the LPG off-loading operation : -

- a) The hand brake of the road tanker shall be applied and the chock blocks securely fitted to undersides of the wheels.
- b) The surrounding shall be checked to ensure that neither source of ignition nor flammable material is present.
- c) Fill-connections shall be visually checked to ensure that they are in safe working conditions.
- d) The storage capacity of the tank to be filled shall be carefully monitored throughout the filling operation by means of the content gauges to avoid over-filling. Bulk tanks shall never be filled beyond the maximum level as specified in Section 4.2.6.1 (see Gas Safety (Gas Supply) Regulation 10).
- e) Earthing/bonding cable shall be engaged before connecting the fill-hose and be disengaged after disconnecting the fill-hose. Earthing/bonding cable and driveaway coupling shall be connected throughout the entire off-loading operation.
- f) A separate fill-hose for vapour return may be used for the off-loading operation.
- g) Fill-connections and fill-hoses shall be checked for leakage throughout the operation.
- h) For installations of more than one tank, each tank shall be filled separately.
- i) Fire extinguishers shall be located at easily accessible positions with warning notices prominently displayed (see Gas Safety (Gas Supply) Regulation 38(1)(b)).

9.3. Replacement of LPG Cylinders

- 9.3.1. This Section covers the operation of cylinder replacement for piped-cylinder stores.
- 9.3.2. The cylinder valve and the isolation valve at the manifold shall be closed before disconnecting each cylinder.
- 9.3.3. The condition of cylinder valves and connections shall be examined for any defects. Any cylinder with damaged or defective threads shall be conspicuously marked for returning to the oil terminal.
- 9.3.4. Cylinders shall be properly installed and securely in an upright position.
- 9.3.5. After a cylinder has been replaced, the cylinder valve shall be gently opened and checked for leakage with soap solution.

9.3.6. Before removing any cylinder from the store, the cylinder valve should be recapped.

9.4. Miscellaneous

9.4.1. Gas supply companies shall report major gas emergencies to the Gas Authority and shall respond to any report of gas escape in accordance with Gas Safety (Registration of Gas Supply Companies) Regulations 15 and 16 respectively.

9.4.2. In the event of any system/equipment failures or emergencies, a record of failed equipment or components, actions taken and relevant information shall be kept for subsequent investigation and examination.

9.4.3. Operational checks such as housekeeping, conditions of regulators and pressure gauges, LPG inventory level, and water level of certain vaporisers, etc. shall be carried out and logged on site as appropriate to ensure safety and proper function of the system.

SECTION 10 MAINTENANCE, EXAMINATIONS AND INSPECTIONS

10.1. General

- 10.1.1. The owner of an LPG installation shall have a duty to maintain and operate the installation in a safe condition and shall employ a competent person to inspect the installation at intervals as specified in Section 10.3.
- 10.1.2. Persons engaged in maintenance work shall have access to maintenance manuals and operating instructions and shall adhere to them accordingly.
- 10.1.3. No unauthorised person shall be permitted to gain access to LPG installations. A proper work permit system incorporating formal procedures shall be instituted for cold work, hot work and entry to bulk tanks.
- 10.1.4. Work permits shall be kept for 5 years as part of the maintenance records.
- 10.1.5. Before re-commissioning, care shall be taken to ensure that all tanks, vaporisers, equipment and associated pipework/fittings (including electrical bonding) are properly re-instated and leak tested satisfactorily.

10.2. Maintenance

- 10.2.1. Maintenance work shall be carried out by suitably trained and experienced persons.
- 10.2.2. Routine maintenance schedule shall be planned in accordance with manufacturer instructions to ensure safety and proper function of the system. The schedule may also depend on the individual site condition and past maintenance records.
- 10.2.3. Site environment shall be maintained in good condition so that it is free of overgrown vegetation and irrelevant materials.
- 10.2.4. Identification labels, emergency instructions, warning signs and line diagrams shall be checked to ensure that they are in place and legible.
- 10.2.5. The earthing and bonding arrangement shall be checked and maintained at regular intervals to ensure its proper function.
- 10.2.6. Vessel chambers and valve chambers shall be checked for integrity and be properly maintained at regular intervals to prevent ingress of water.
- 10.2.7. Each electrical equipment and cable connection shall be inspected and properly maintained to ensure satisfactory condition in accordance with manufacturer instructions.
- 10.2.8. Fire extinguishers, gas detectors and water spray systems (if any) shall be checked, tested and maintained at regular intervals in accordance with the manufacturer instructions or other schedules specified by the Fire Services Department.

- 10.2.9. Vaporisers including water level controls, heat input controls and solenoid valves, etc. shall be checked and maintained at regular intervals in accordance with manufacturer instructions.
- 10.2.10. LPG tanks, pipework and associated fittings shall be inspected and properly maintained at regular intervals against corrosion.
- 10.2.11. Pigtails for piped-cylinder stores shall be replaced when they show visible signs of deterioration and in any case at intervals not exceeding 5 years (see Section 4.3.2).
- 10.2.12. All other equipment (e.g. pressure gauges and pressure regulators etc.) shall be checked and maintained to ensure satisfactory condition and proper function in accordance with manufacturer instructions at intervals not exceeding 1 year as practicable and replaced with new or reconditioned units as necessary.
- 10.2.13. Maintenance records shall be kept by the owner for the service life of the installation.

10.3. Tests, Examinations and Inspections

10.3.1. General

- 10.3.1.1. Tests and examinations for revalidation of tanks, vaporisers, pipework and associated fittings, etc. shall be carried out in accordance with the schedule in Appendix K. The schedule shall be planned well ahead to ensure timely completion of the work.
- 10.3.1.2. Examination, inspection and certification of LPG cylinders, tanks, vaporisers, pipework or associated fittings shall be carried out by a competent person (See Appendix B1). Test certificates and examination records shall be kept for the service life of respective equipment/system.
- 10.3.1.3. When it is necessary to purge LPG tanks, vaporisers, pipework or associated fittings out of service for examinations and inspections, the procedures in Section 8.5 shall be followed.

10.3.2. LPG Tanks

- 10.3.2.1. Aboveground tanks shall be subject to visual external examination at intervals not exceeding 5 years. Mini-tanks shall also be subject to hydraulic test in accordance with respective design codes. At 10-year intervals aboveground bulk tanks shall also be subject to magnetic particle, ultrasonic thickness and hydraulic tests (see Gas Safety (Gas Supply) Regulation 8(3)). If manhole is provided, internal visual examination shall also be required.

For tanks with fireproof coating, they shall be subject to visual internal and external examinations, magnetic particle, ultrasonic thickness and hydraulic tests at intervals not exceeding 5 years.

- 10.3.2.2. Underground/mounded bulk tanks shall be subject to internal and external examinations, magnetic particle, hydraulic and ultrasonic thickness, paint thickness and holiday tests not exceeding 10 years after being put into service. Thereafter, tanks shall be examined and tested at intervals not exceeding 5 years (see Gas Safety (Gas Supply) Regulation 8(4)).
- 10.3.2.3. For visual examination of bulk tanks, special attention shall be given to signs of corrosion, deterioration, condition of tank supports and welded joints.
- Any defects shall be rectified prior to recommissioning of the bulk tanks (see Gas Safety (Gas Supply) Regulation 8(6)).
- 10.3.2.4. Pressure relief valves shall be replaced at intervals not exceeding 5 years with new or reconditioned units of appropriate set pressure and capacity. If the bulk tank is under pressure, the relief valve(s) shall not be removed unless a multiport or check device is provided. In this case, a serviceable relief valve shall be made available for immediate replacement.
- 10.3.2.5. Cathodic protection system shall be checked for its proper function at intervals not exceeding 6 months, and its records maintained for the service life of the tank (see Gas Safety (Gas Supply) Regulation 12 (2)).

10.3.3. Vaporisers and Pipework

- 10.3.3.1. Vaporisers and associated relief valves shall be hydraulically tested at intervals not exceeding 5 years in accordance with respective design codes (see Gas Safety (Gas Supply) Regulation 14).
- 10.3.3.2. All exposed pipework shall be subject to annual visual examination and leak test under operating pressure using soap solution.
- 10.3.3.3. Pressure tests shall be carried out in accordance with Section 8.3 upon re-instatement of disconnected pipework. A leak test shall be carried out on joints upon re-instatement of replaced/repairs fitting and equipment such as pressure gauges and regulators.
- 10.3.3.4. HPRVs shall be replaced at intervals not exceeding 10 years with new or reconditioned units of appropriate set pressure.

10.3.4. LPG Compounds and Cylinder Stores

- 10.3.4.1. An LPG compound or cylinder store shall be inspected annually by a competent person (See Appendix B2) to ascertain whether the installation is maintained and operated in a safe manner in accordance with relevant sections in this module. The owner of the LPG compound and cylinder store shall submit such inspection reports to the Gas Authority (See Appendix J) within four weeks after the inspection.
- 10.3.4.2. The owner of an LPG compound or cylinder store shall carry out the necessary remedial work as identified in the inspection reports.

**APPENDIX A RELEVANT SECTIONS IN RELATION TO THE GAS SAFETY
(GAS SUPPLY) REGULATIONS**

Gas Safety (Gas Supply) Regulations	Relevant Sections in Module 1	Sections Quoted in Module 1
Reg. 2: Interpretation	1	-
Part II: Construction and use of notifiable gas installations (Reg. 3 - 6)	2.2, 2.3	2.2.1
Reg. 7: Only approved containers may be used to contain LPG	4.2.1	4.2.1.1
Reg. 8: Examinations and inspections to be carried out on cylinders and tanks	8, 10.3.2	10.3.2.1, 10.3.2.2, 10.3.2.3
Reg. 9: Pressure relief valves fitted to cylinders	4.2.5	-
Reg. 10: Filling capacity of tanks and cylinders	9.2, 9.3, 4.2.6	4.2.6.1, 9.2.6(d)
Reg. 11: Requirements for LPG storage installations	3.1, 3.2, 3.3, 4.2, 4.3, 4.4, 4.8	3.1.1.2, 3.1.1.3, 3.2.1.1, 4.3.3.2
Reg. 12: Requirements for tanks	4.2.4, 7.2.1, 7.2.2, 7.5, 10.3.2	4.2.4.2, 4.2.4.3, 10.3.2.5
Reg. 13: Provision of shut-off valves for vaporisers	4.4.1.6	4.4.1.6
Reg. 14: Testing and examination of vaporisers	8, 10.3.3	10.3.3.1
Reg. 15: Application	1	-
Reg. 16: Only competent persons to carry out work on or in relation to gas pipes	7, 8, 9, 10	-
Reg. 17: General safety requirements for gas pipes	4.6	4.6.2
Reg. 18: Enclosed gas pipes	4.6.1.6	-
Reg. 19: Protection of premises	-	-
Reg. 20: Pressure tests on gas pipes, etc.	8.3	8.3.8
Reg. 21: General safety requirements for pressure-regulating installations	4.5	4.5.1.1
Reg. 22: Location of Pressure-regulating installations	-	-
Reg. 23: Purging, etc. of gas pipes	8.4, 8.5	-
Reg. 38: Certain equipment to be carried on gas vehicle	9.2.6 (i)	9.2.6 (i)
Reg. 39: Only competent persons to be employed on gas vehicle	9.2.1	9.2.1
Reg. 40: Safety device to be used when LPG is discharged from road tanker	3.1.5.5	3.1.5.5

**APPENDIX B1 ACCEPTANCE CRITERIA FOR ENLISTMENT
BY THE GAS AUTHORITY AS COMPETENT PERSON**

**Class 1(a) - Testing and certification of LPG tanks, vaporisers and mains OR
Class 1(b) – Testing and certification of LPG cylinders**

1. Responsibilities

(a) For testing and certification of LPG tanks, vaporisers and mains

LPG Tanks

- Visual inspections of LPG tanks prior to testing.
- Supervise pressure testing of LPG tanks.
- Ensure that non-destructive testing and examination of LPG tanks are carried out in accordance with appropriate procedures and vessel codes.
- Certify that they are suitable for LPG service.

LPG Vaporisers and Mains

- Ensure that pressure testing of LPG vaporisers/mains is carried out in accordance with appropriate procedures and codes.
- Certify that tested LPG vaporisers/mains meet the required standards.

(b) For testing and certification of LPG cylinders

LPG Cylinders

- Ensure that LPG cylinders are inspected and tested in the prescribed manner.
- Certify that tested LPG cylinders meet the required standards.

2. Qualification

Corporate Member of the Hong Kong Institution of Engineers in the Mechanical, Chemical, Gas or Marine & Naval Architecture disciplines; or equivalent professional attainment such as Corporate Member of the Institution of Mechanical Engineers, Institution of Chemical Engineers, Institution of Gas Engineers and Managers or Institution of Marine Engineering, Science & Technology.

3. **Knowledge and Working Experience Required**

(a) **To carry out testing and certification of LPG tanks, vaporisers and mains**

Have full understanding of the following subjects:

- Design codes and test standards pertaining to LPG tanks, vaporisers, mains, valves and associated equipment.
- Non-destructive testing technology applicable to LPG tanks, vaporisers and mains;
- Strength of materials and other properties of materials used on LPG tanks, vaporisers and mains;
- Properties of LPG and related Codes of practices and Guidelines; and

Possess at least 1-year relevant working experience in the testing of pressure vessels.

(b) **To carry out testing and certification of LPG cylinders**

Have full understanding of the following subjects:

- Design codes and test standards pertaining to LPG cylinders and associated equipment.
- Non-destructive testing technology applicable to LPG cylinders.
- Strength of materials and other properties of materials used on LPG cylinders.
- Properties of LPG and related Codes of practices and Guidelines; and

Possess at least 1-year relevant working experience in the testing of cylinders

Notes:

- (i) According to the interpretation as stated in the Gas Safety Ordinance (Cap 51),
"Tank" means a bulk tank or mini-tank; "Bulk tank" means a receptacle which has a water capacity of more than 450 litres and used, or to be used, to contain liquefied petroleum gas;
"Mini-tank" means a receptacle with a water capacity of more than 150 litres but not more than 450 litres and used, or to be used, to contain liquefied petroleum gas;
"Vaporiser" means any equipment used, or to be used, to provide heat for the vaporisation of liquefied petroleum gas;
"Gas main" means a pipe, other than a service pipe or installation pipe, used, or to be used, to supply gas;
"Cylinder" means a receptacle which has a water capacity of not more than 150 litres; and used, or to be used, to contain liquefied petroleum gas.
- (ii) The applicant may submit, together with the application form, relevant documentary proof such as training records or employer references in respect of his/her training and experience in the testing of pressure vessels/ cylinders.
- (iii) The Gas Authority may require the applicant to attend an interview for verifying the appropriateness of his/her training and experience.
- (iv) For an applicant who is a Registered Professional Engineer in the Mechanical, Chemical, Gas or Marine & Naval Architecture Disciplines under the Engineers Registration Ordinance (Cap 409), interview may not be required if his/ her submitted application form is accompanied with adequate documentary proof in respect of his/ her training and experience in the testing of pressure vessels/ cylinders.
- (v) The performance of all competent person of Class 1(a) and Class 1(b) shall be subjected to the monitoring of a performance monitoring system of which details are listed in EMSD website http://www.emsd.gov.hk/emsd/eng/pps/gas_pms.shtml.
- (vi) When a competent person ceases to practise in the gas industry for 12 months or ceases to maintain any professional qualification in Mechanical, Chemical, Gas or Marine & Naval Architecture Disciplines, his/her name may be removed from the register.
- (vii) If a competent person changes his/her employer within the gas industry or correspondence address or ceases to maintain any professional qualification in Mechanical, Chemical, Gas or Marine & Naval Architecture Disciplines, he/she shall notify the Gas Authority of the change within 28 days.

APPENDIX B2 ACCEPTANCE CRITERIA FOR COMPETENT PERSON UNDER GAS SAFETY ORDINANCE, CAP. 51

Class 2 - Inspection and Certification of LPG Compounds and Cylinder Stores

1. Responsibilities

- (a) Inspect LPG compounds and cylinder stores to ensure that they are maintained and operated in accordance with the requirements under the Gas Safety Ordinance and relevant codes of practice.
- (b) Ensure proper record of maintenance, repair and alteration works.
- (c) Prepare reports for periodic inspection of LPG installations.

2. Knowledge Required

Must have a full understanding of the following subjects :-

- (a) The Gas Safety Ordinance and subsidiary regulations.
- (b) Design codes and standards pertaining to LPG compounds and cylinder stores.

3. Acceptance Criteria

Applicants must :

- (a) be qualified to any one of the following professions or equivalent professional attainment with at least 1 year of relevant working experience :
 - (i) Corporate Member of the Hong Kong Institution of Engineers in the Mechanical, Chemical, Marine, or Gas Engineering disciplines;
 - (ii) Corporate Member of one of the following : Institution of Mechanical Engineers, Institution of Chemical Engineers, Institution of Marine Engineers, or Institution of Gas Engineers; or
- (b) have a recognised degree in mechanical, chemical, marine or gas engineering with at least 5 years of relevant working experience; or
- (c) have a recognised higher diploma or high certificate in mechanical, chemical, marine or gas engineering with at least 10 years of relevant working experience.

Notes :-

- (i) The Gas Authority may require the applicant to attend an interview for verifying the appropriateness of his/her training and experience. Applicant who is not a Corporate Member of any appropriate professional institution may be required to sit for a written examination.
- (ii) When a competent person ceases to practise in the gas industry for 12 months, his/her name may be removed from the register.
- (iii) If a competent person changes his/her employer within the gas industry, he/she shall notify the Gas Authority of the change within 28 days.

APPENDIX C

BUILDINGS DEPARTMENT

PRACTICE NOTE FOR AUTHORISED PERSONS AND REGISTERED STRUCTURAL ENGINEERS

GAS SUPPLY INSTALLATIONS

1. INTRODUCTION

1.1 The purpose of this guidance note is to -

- (a) draw the attention of Authorized Persons and developers to the Government's piped gas policy and the need to design a gas supply installation at an early stage of a development; and
- (b) give guidance on the location criteria which must be met in the design of the gas supply installation.

1.2 In some instances, other arrangements may be deemed to be acceptable by the Gas Authority and each case will be carefully considered on its merits and in the light of any special circumstances to which attention may be drawn.

2. GAS AUTHORITY

The Director of Electrical and Mechanical Services (DEMS) is the Gas Authority appointed by the Chief Executive of the Hong Kong Special Administrative Region for the purposes of the Gas Safety Ordinance. The Gas Standards Office which acts on behalf of the Gas Authority is responsible for matters relating to gas safety. The address and contact telephone number of the Gas Standards Office are as follows: -

Address: 6/F. EMSD
98 Caroline Hill Road,
Causeway Bay,
Hong Kong.

Telephone: 2808 3683

3. PIPED GAS POLICY

3.1 The Government's piped gas policy is aimed at providing safe gas supplies to all domestic buildings as far as possible as a means of discouraging the use of cylinders.

- 3.2 It is important that the choice of fuel gas is decided at an early stage when preparing the design of a development so that sites can be set aside for the equipment associated with a piped gas supply.

4. THE GAS SUPPLY INSTALLATION

4.1 General

A gas supply installation is considered to be safe and adequate if it -

- (a) has a gas source which can, so far as is reasonably practicable, provide an uninterrupted supply of gas to the consumers being supplied;
- (b) is designed and located such that it does not present an unacceptable risk to health and safety of members of the public residing or working in the vicinity of the installation;

NOTE: Details of current Government Risk Guidelines are included in the Hong Kong Planning Standards and Guidelines, Chapter 11: Miscellaneous Planning Standards and Guidelines.

4.2 The Gas Source

4.2.1 The gas source may take the form of either -

- (a) a supply of Towngas from the reticulated mains network of the Hong Kong and China Gas Company Limited (HKCG); or
- (b) a supply of LPG from a storage installation located on or adjacent to the development being supplied.

4.2.2 If Towngas is to be used, the developer should liaise with HKCG for the design of the pipe routes to and within the development and make provision for the safe siting of any gas control equipment which has to be installed.

4.2.3 If LPG is to be used -

- (a) the developer should liaise with the prospective LPG supplier at an early stage for the siting of the LPG storage facility and the design of the pipe routes within the development;
- (b) the LPG is normally stored in containers of the following types -
 - (i) bulk tank (underground or mounded); or
 - (ii) banks of LPG cylinders.

NOTE: The maximum number of LPG cylinders which may be used for an LPG cylinder bank installation is twenty. The maximum size of cylinder is 50 kg (118 litre).

- (c) an LPG store where containers are kept with an aggregated nominal water capacity of more than 130 litres is classified as an Notifiable Gas Installation (NGI) under the Gas Safety Ordinance Cap. 51 and application for construction approval to the Gas Authority is required;
- (d) the storage of LPG should normally have an aggregate capacity of four times the average foreseeable daily demand.

5. LOCATION CRITERIA

- 5.1 Installations for the supply of gas from the reticulated mains system of the HKCG shall be located in accordance with the requirements of the Gas Safety Ordinance Cap. 51. Conformance with the HKCG's approved codes of practice shall normally be deemed to meet these requirements.
- 5.2 Installations for the supply of LPG shall be designed, located and constructed in accordance with the Gas Safety (Gas Supply) Regulations. The attention of AP's and other applicants is drawn particularly to the requirements of Regulation 11 which concerns the ventilation of, access to and fire protection measures for LPG installations.
- 5.3 Installations should normally be located at ground floor level away from any unventilated voids to prevent accumulation of LPG in the event of a gas leak. Locations in basements, open pits, over voids or above ground level (including podium level) will not be permitted.
- 5.4 Fire services facilities of gas installations shall comply with the requirements of the Director of Fire Services.
- 5.5 For bulk LPG stores where replenishment of LPG by road tanker is necessary, careful consideration should be given to the location of the installation. Factors to be considered include the estimated population in the vicinity, the capacity of the storage containers, the arrangements for road tanker access and unloading, etc. A Quantitative Risk Assessment (QRA) report should normally be submitted with the application for NGI construction approval to the Gas Authority, to demonstrate that the installation will not present unacceptable risks to society. It is recommended that the study brief is discussed with the Gas Authority prior to the appointment of consultants.
- 5.6 The following specific requirements for bulk tank LPG installations should be complied with: -
 - (a) installations and associated road tanker unloading points should be sited away from places where people would congregate in order to reduce risk levels. The Gas Authority should be consulted at an early stage where it is proposed to site the installation within 100 metres of schools, hospitals and homes for the elderly or other sensitive users;

- (b) there shall be a paved area surrounding the installation, a minimum of 1m wide, and should have a further area 2m wide which is free of trees, shrubs, etc.;
- (c) the minimum safety distance from buildings* and the lot boundary shall meet the requirements of the LPG Code of Practice, Module 1 published by the HKSAR, e.g. filling point or valve assembly on the manhole of any tank shall be at least 7.6 m from buildings, property line or any fixed point of ignition.

***NOTE:** The acceptability of the location of any bulk LPG installation will be determined by reference to the QRA. As a general rule, however, for high rise residential property, a separation distance of between 35 and 100 metres may be necessary, depending on the quantity of LPG stored and the size of the road tanker used for replenishing stocks of LPG.

5.7 The guidelines below give approximate area requirements for LPG installations with underground bulk tanks: -

LPG Storage Quantity (tonnes)	Approx. Area of Compound for U/G LPG tanks (m x m)
4	13 x 12
6	14 x 12
8	15 x 12
10	16 x 13
15	18 x 15
20	25 x 20
40	25 x 25

Gas Standards Office

APPENDIX D MINIMUM SAFETY DISTANCES FOR UNDERGROUND/MOUNDED LPG BULK TANKS

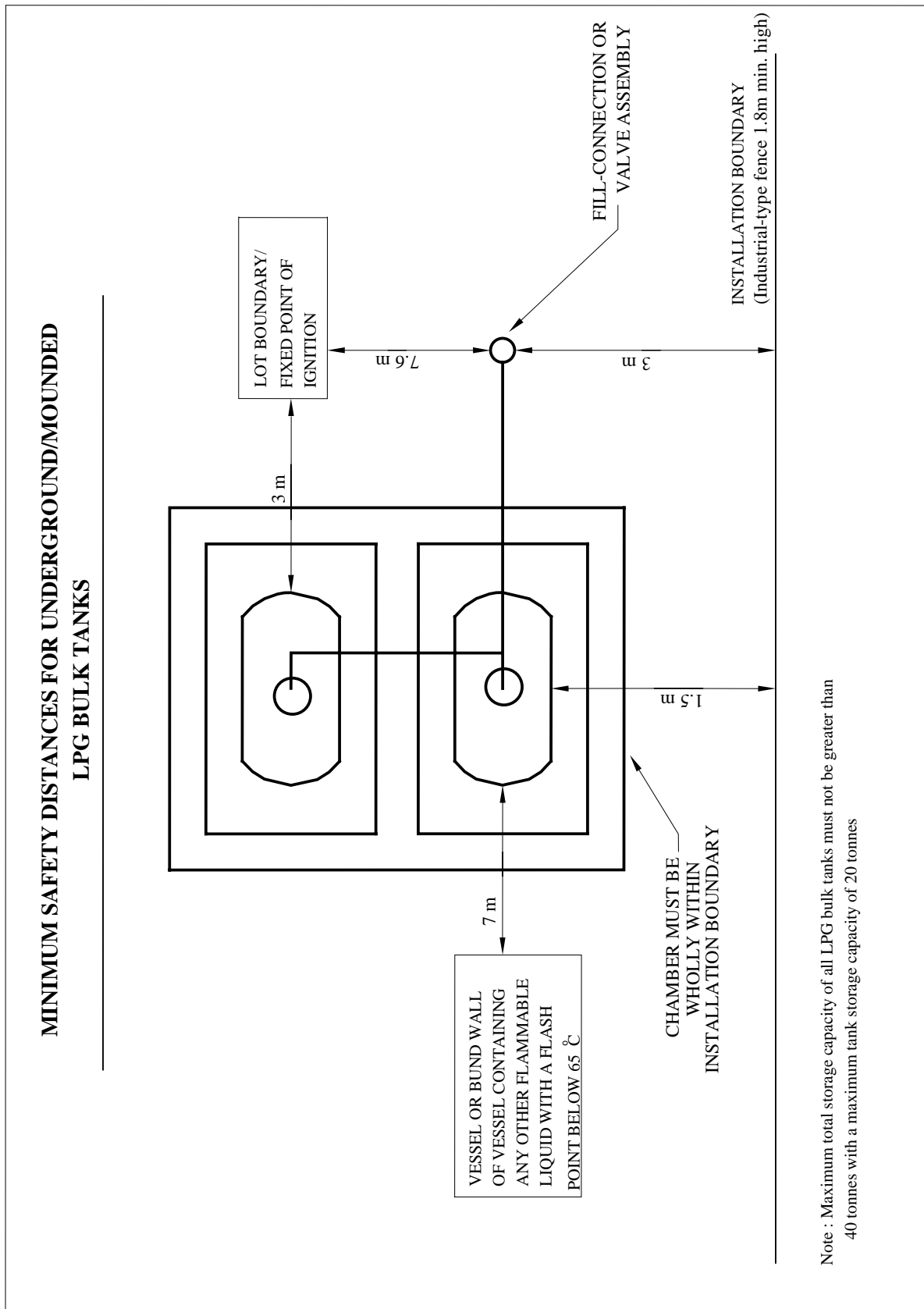

APPENDIX E TYPICAL DESIGN FOR LPG TRAP

Sample Calculation of LPG Trap

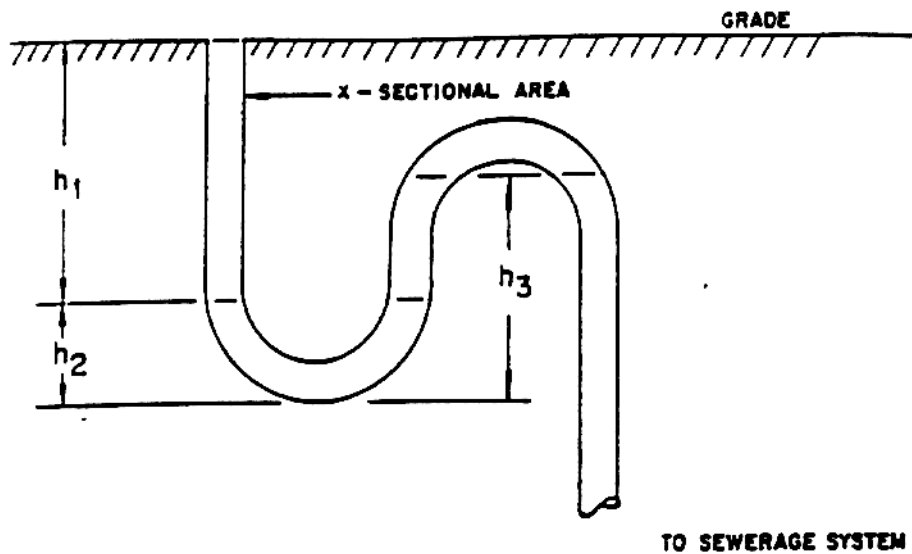

h_3 is the required height of the trap to prevent overspilling LPG through the trap to the sewerage system. It is calculated based on that if h_2 is filled with water and h_1 is filled to grade with liquid LPG, the water in h_3 can balance the LPG in h_1 and thus in a no flow position.

$$h_3 \times \text{S.G. of water} = h_2 \times \text{S.G. of water} + h_1 \times \text{S.G. of LPG}$$
$$h_3 = h_2 + h_1 \times \text{S.G. of LPG/S.G. of water}$$

Notes on Calculation:

- (1) The foregoing does not account for additional head of LPG above grade. Assuming a liquid spill, the height of the assumed layer above grade shall be added to the above calculation.
- (2) If there is no LPG, $h_2 = h_3$.
- (3) S.G. = Specific Gravity

APPENDIX F TYPICAL SCHEMATIC DIAGRAM FOR LPG COMPOUND

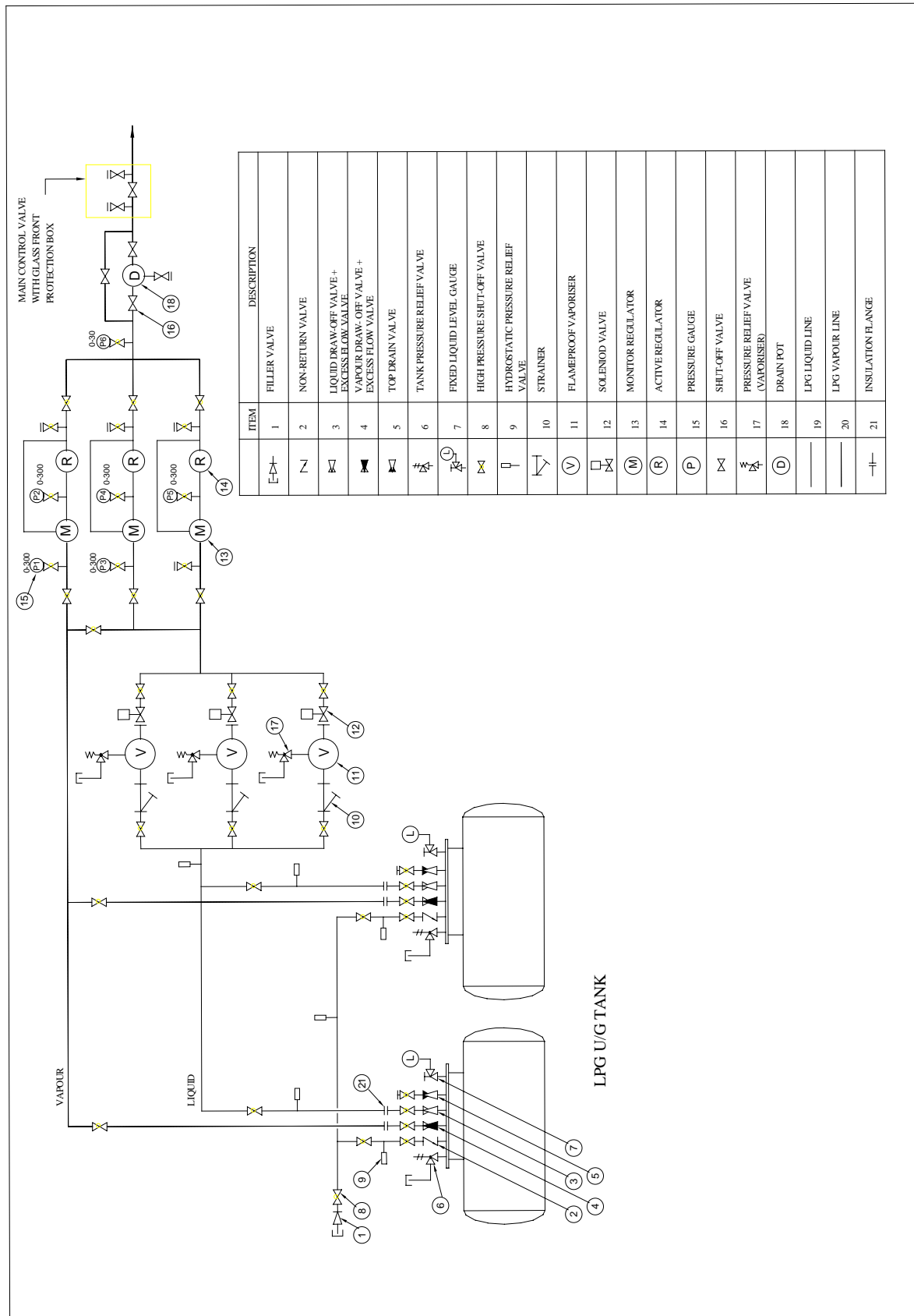



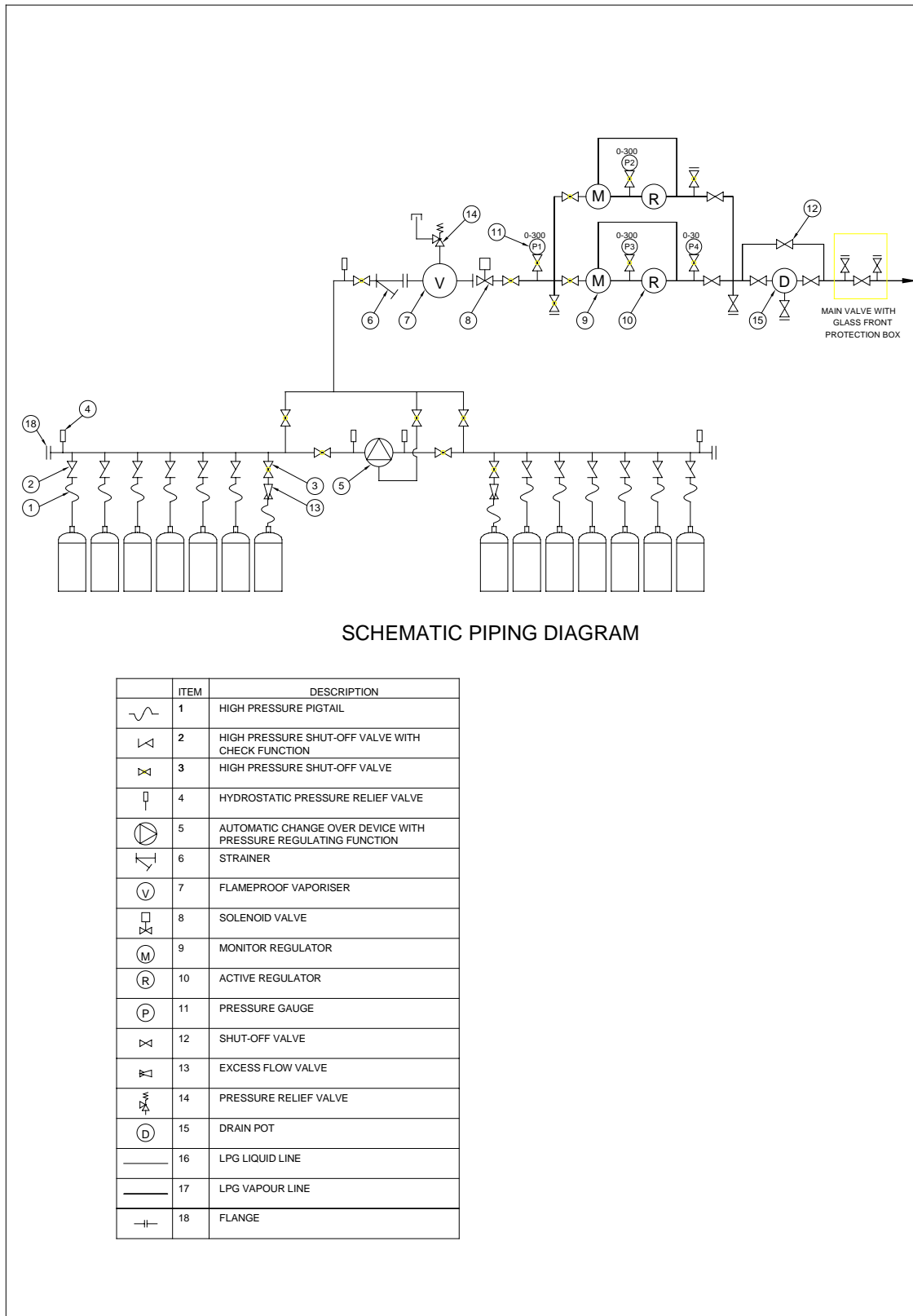



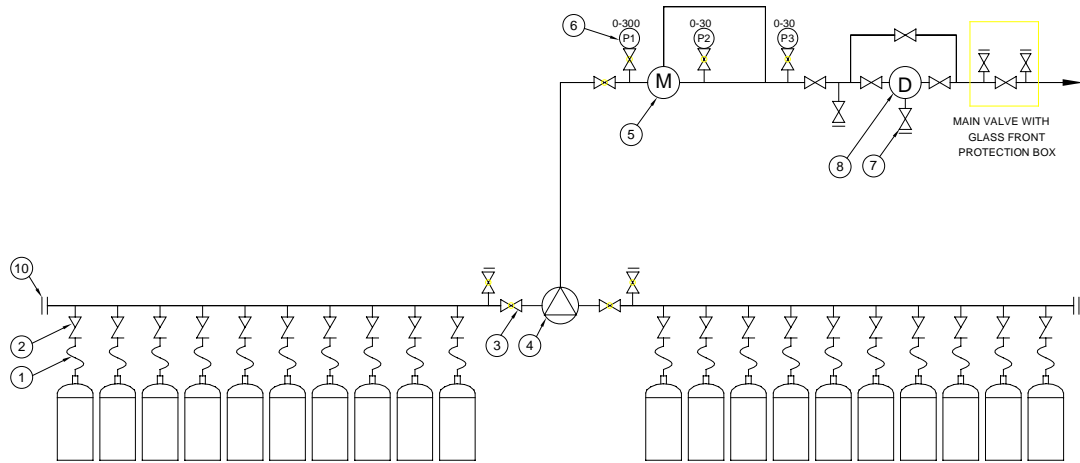



APPENDIX G TYPICAL SCHEMATIC DIAGRAM FOR PIPED-CYLINDER STORE



**Figure G1
Liquid Withdrawn**



SCHEMATIC PIPING DIAGRAM

	ITEM	DESCRIPTION
	1	HIGH PRESSURE PIGTAIL
	2	HIGH PRESSURE SHUT-OFF VALVE WITH CHECK FUNCTION
	3	HIGH PRESSURE SHUT-OFF VALVE
	4	AUTOMATIC CHANGE-OVER DEVICE WITH PRESSURE REGULATING FUNCTION
	5	MONITOR REGULATOR
	6	PRESSURE GAUGE
	7	SHUT-OFF VALVE
	8	DRAIN POT
	9	LPG VAPOUR LINE
	10	FLANGE

**Figure G2
Vapour Withdrawn**

APPENDIX H AREA CLASSIFICATION FOR LPG COMPOUND AND CYLINDER STORE

Location	Extent of Classified Area	Area Classification	
Bulk Tank	(a) Within 1.5m in all directions from the tank connections.	Zone 1	
	(b) Up to 1.5m above ground level and decreasing uniformly to zero within 3m from the tank shell; excluding the area covered by (a) above.	Zone 2	
Pressure Relief Valve	(a) Within direct path of discharge.	No fixed electrical equipment	
	(b) Within 1.5m in all other directions.	Zone 1	
	(c) Beyond 1.5m but within 4.5m in all directions from the point of discharge.	Zone 2	
Fill-connection	(a) Within 1.5m in all directions.	Zone 1	
	(b) Beyond 1.5m but within 4.5m in all directions.	Zone 2	
Vaporiser (i) Outdoors	(a) Within 1.5m in all directions.	Zone 1	
	(b) Beyond 1.5m but within 3m in all directions from the vaporiser.	Zone 2	
	(ii) Indoors	Entire room and any adjacent room not separated by a vapour-tight partition.	Zone 1
Cylinder Store (i) Open Air Storage	In the storage space up to a height of 1.5m above the top of the stack, or beneath any roof over the storage space.	Zone 2	
	Outside the storage space or the space covered by any roof up to 1.5m above ground level and decreasing uniformly to zero within the separation distance set out in Table 3.1.	Zone 2	
	(ii) Storage Within Building	Inside building.	Zone 2
	Outside any doorway, low level opening of the store, up to 1.5m above ground level and decreasing uniformly to zero within the separation distance set out in Table 3.1.	Zone 2	

Note 1 Any pit, trench, duct entry or depression falling within or below a Zone 1 or Zone 2 location shall be treated as being Zone 1 throughout, unless a suitable interceptor is installed.

Note 2 For electrical hazards, attention is drawn to the 'Electricity at Work Regulations' (SI 635) and the associated HSE Guidance HS (R) 25.

Note 3 The term 'outdoors' includes vaporisers which are covered by a canopy.

APPENDIX I1

Testing and Examination of LPG Tank under Regulation 8 of Gas Safety (Gas Supply) Regulations, Cap. 51

GasSO Ref. :

To : The Gas Authority

Address of Notifiable Gas Installation : _____

Mode of Storage, Serial No., Water Capacity & Tank Design Code : _____

Date of Installation & Last Revalidation : _____

I certify that the above tank has satisfactorily been tested and examined under my supervision in accordance with the Gas Standards Office's requirements in order to comply with Regulation 8 of the Gas Safety (Gas Supply) Regulations and it is suitable for LPG service :-

Test / Examination	Test Date(s)	Attached Document Reference No.	Tested by	Remarks
Full visual examination & hydraulic test				
Ultrasonic thickness test				
Magnetic particle test				
Paint thickness & holiday tests				
Testing & examination of tank fittings				
Cathodic protection test				
Electrical continuity test				

Certified by
Competent Person : _____

Company Chop : _____

Signature : _____

Company Name : _____

Date : _____

EMSD/GSO/106

APPENDIX I2

Testing and Examination of LPG Vaporiser under Part IV of Gas Safety (Gas Supply) Regulations, Cap. 51

GasSO Ref. : _____

To : The Gas Authority

Address of Notifiable Gas Installation : _____

I certify that the LPG vaporiser(s) installed at the above premises has satisfactorily been tested and examined under my supervision in accordance with the Gas Standards Office's requirements in order to comply with Part IV of the Gas Safety (Gas Supply) Regulations. The test and examination was carried out by _____ of _____

_____ on _____

Details of vaporiser(s) and test are as follows :-

	(1)	(2)	(3)
Make & Model			
Serial Number			
Date of Manufacture			
Vaporising Capacity (kg/hr)			
Pressure Vessel Code			
Test Pressure (kPa)			
Duration of Test (Hr)			
Pressure Relief Valve			
Overall Condition			

Certified by
Competent Person : _____

Company Chop : _____ Signature : _____

Company Name : _____ Date : _____

EMSD/GSO/107

APPENDIX I3

Testing and Examination of LPG Pipes under Part V of Gas Safety (Gas Supply) Regulations, Cap. 51

GasSO Ref. :

To : The Gas Authority

Address of Notifiable Gas Installation : _____

I certify that all liquefied petroleum gas pipework installed at the above premises is constructed of suitable materials and has been tested/examined in accordance with the Gas Standards Office's requirements. All pipework has been adequately protected against corrosion in accordance with the specifications. The test/examination was carried out by _____ of _____

_____ on _____

Details of pipework materials and tests are as follows :-

Section of Pipework	All liquid Lines	All High Pressure Vapour Lines before Primary Regulating System	All Medium Pressure Vapour Lines	All Low Pressure Vapour Lines
Pipeline specification				
Fitting specification				
Valve material and rating				
Testing medium				
Working pressure (kPa)				
Test pressure (kPa)				
Duration of test (Hr)				
Pressure setting of Hydrostatic Pressure Relief Valve (kPa)		N/A	N/A	N/A

Remarks : Pressure drop observed? Yes/No.

If 'Yes', please specify causes and remedial actions : _____

Certified by
Competent Person : _____

Company Chop : _____ Signature : _____

Company Name : _____ Date : _____

APPENDIX J

**THE GOVERNMENT OF THE HONG KONG
SPECIAL ADMINISTRATIVE REGION
FORM 109
GAS SAFETY (GAS SUPPLY) REGULATIONS (Chapter 51)
ANNUAL INSPECTION REPORT OF LPG INSTALLATION**

To : The Gas Authority

GasSO Ref :

Section I Particulars of LPG Installation

Location	
Owner	
Gas Supply Company	
Maintenance Contractor	
Type of Installation	LPG Compound/ Piped-cylinder Store/ Standby Cylinder Store*
Storage Quantity	x m ³ /kg*
Mode of Storage	Aboveground tank/Mounded tank/ Underground tank/ Mini-tank/ Cylinder (Liquid/Vapour withdrawal)*

Section II Inspection Checklist

A	Site Condition	< >	E	Bulk Tanks & Tanker Bay	< >
1	Structures/fittings* within safety distance		1	Condition of valve chambers	
2	Condition of sterile area		2	External condition of vessel chambers	
3	Condition of fence/boundary walls/gates*		3	Internal condition of vessel chamber (ingress of water)	
4	Housekeeping		4	Provision of rain caps, valve chamber covers, etc.	
5	Condition of catchment pits/drains/gully covers*		5	Condition of PRVs and vent pipes	
6	Type and number of certified unexpired fire extinguishers		6	External condition of aboveground tanks	
7	Condition of warning signs/emergency notices*		7	Condition of earthing/bonding connection*	
8	Others		8	Condition of breakaway coupling/loading arm*	
			9	Date of tank revalidation	
			10	Record of cathodic protection test	
			11	Record of routine test of fire fighting system	
B	Record of Maintenance and Alterations	< >	12	Others	
1	Maintenance records				
2	Alteration records				
3	Others				
			F	Cylinder Store	< >
			1	Housekeeping of cylinder store	
C	Vaporiser Room	< >	2	Condition of ventilation and explosion relief	
1	Housekeeping of vaporiser room		3	All flexible gas tubings with valid markings	
2	Condition of ventilation and explosion relief		4	Record of routine test of fire fighting system	
3	Condition of vaporisers		5	Others	
4	Condition of PRVs and vent pipes				
5	Date of vaporiser revalidation		G	Remarks/Other Information	
6	Record of routine test of fire fighting system				
7	Others				
D	Pipework/Equipment	< >			
1	Condition of pipework/pressure regulators/valves gauges/fittings*				
2	Identification markings of pipework/valves/fittings*				
3	Identification and functional markings of main control valve				
4	Date of pipework test				
5	Date of HPRV replacement				
6	Others				

Note : X cross if unsatisfactory; ✓ tick if satisfactory; NA if not applicable * delete as appropriate

Section III Recommendations and Remedial Work

(A) Recommendations by Competent Person		(B) Remedial work done by Owner	
Checklist Item	Description	Tick if Completed	Planned Completion Date
Overall Comments	1. I am of the opinion that at the time of inspection the general condition of the LPG installation was/ was not* satisfactory. 2.I recommend _____ _____	<i>Remark : The owner of LPG Installation should inform the Gas Standards Office in writing upon completion of the remedial work.</i>	

Note : Please use additional sheets if necessary

Section IV Declaration

(A) Competent Person This is to certify that the above installation was inspected on _____ by _____ (Date) _____ of _____ (Competent Person) (Company Name)	
and the foregoing is a correct report of the results of the inspection. Signature : _____ Company Chop : _____	
(B) Owner I/We hereby submit an inspection report of the above installation in accordance with Regulation 6C of Part IIA of the Gas Safety (Gas Supply) Regulations, Cap. 51. Date of Submission : _____ Signature : _____ (Name : _____) Contact Telephone No. : _____	

Explanatory Notes :

1. This report is to be used for annual inspection of LPG installation referred to in paragraph (f) of 'notifiable gas installation', as required by Part IIA under the Gas Safety (Gas Supply) Regulations, Cap. 51.
2. The owner shall employ a competent person to inspect the LPG installation annually. The competent person should complete appropriate Sections I, II, III(A) & IV(A) of the report and the owner should complete Sections III(B) & IV(B) of the report. The report shall be kept by the owner for the service life of the installation.
3. The owner shall submit a copy of the report to Gas Standards Office, Electrical & Mechanical Services Department, 98 Caroline Hill Road, Causeway Bay, Hong Kong by mail or by fax (2576 5945) within 4 weeks after the inspection.
4. The owner shall carry out the necessary remedial work on the LPG installation as recommended in the inspection report.
5. Failure to comply with the requirements of inspection by a competent person and/or the requirement of submission of inspection report is an offence and the owner is liable on conviction to a fine of \$5,000.

APPENDIX K SUMMARY OF TESTS, EXAMINATIONS AND INSPECTIONS

Particular	Frequency of Test/Examination/Inspection	Examination/Test/Inspection performed	Reference
Underground/mounded tank	i) At least once in the first 10-year period following initial use, and ii) After expiration of the period referred to in paragraph (i), in the 5-year period immediately preceding continued use.	<ul style="list-style-type: none"> • Visual internal & external examinations • Hydraulic test • Ultrasonic thickness test • Magnetic particle test • Paint thickness test • Holiday test 	10.3.2.3 8.2.2 8.1.1 8.1.1 7.2.1 7.2.1
Aboveground tank with manhole	5 years	<ul style="list-style-type: none"> • Visual external examination 	10.3.2.3
	10 years	<ul style="list-style-type: none"> • Visual internal & external examinations • Hydraulic test • Ultrasonic thickness test • Magnetic particle test 	10.3.2.3 8.2.2 8.1.1 8.1.1
Aboveground tank without manhole	5 years	<ul style="list-style-type: none"> • Visual external examination 	10.3.2.3
	10 years	<ul style="list-style-type: none"> • Visual external examination • Hydraulic test • Ultrasonic thickness test • Magnetic particle test 	10.3.2.3 8.2.2 8.1.1 8.1.1
Aboveground tank with fireproof coating	5 years	<ul style="list-style-type: none"> • Visual internal & external examination • Hydraulic test • Ultrasonic thickness test • Magnetic particle test 	10.3.2.3 8.2.2 8.1.1 8.1.1
Mini-tank	5 years	<ul style="list-style-type: none"> • Visual examination • Hydraulic test 	10.3.2.3 10.3.2.1
Vaporiser	5 years	<ul style="list-style-type: none"> • Hydraulic test 	10.3.3.1
Pressure relief valve	5 years	<ul style="list-style-type: none"> • Replaced/reconditioned 	10.3.2.4
Cathodic protection system	6 months	<ul style="list-style-type: none"> • Functional test and inspection 	4.2.4.6
Exposed pipework	Annually	<ul style="list-style-type: none"> • Visual/leak test 	10.3.3.2
Hydrostatic pressure relief valve	10 years	<ul style="list-style-type: none"> • Replaced/reconditioned 	10.3.3.3
LPG installation	Annually	<ul style="list-style-type: none"> • Inspection of site, equipment and maintenance records 	Appendix J