

Our reference 本署檔號 :

(36) in EMSD/LESD 7-2/4

Your reference 來函檔號 :

Telephone 電話號碼: (852) 2808 3651  
Facsimile 圖文傳真: (852) 2504 5970

March 5, 2007

All Registered Lift/Escalator Contractors / Engineers

Dear Sirs,

**Circular No.: 4/2007**  
**Code of Practice on the Design and Construction**  
**of Lifts and Escalators (2000 Edition)**  
**Amendment No. 11 – Incorporation of Part 6 of the Code of Practice**

Pursuant to section 27G of the Lifts and Escalators (Safety) Ordinance, Cap. 327, the Code of Practice on the Design and Construction of Lifts and Escalators (2000 Edition) (the Design Code) is updated by incorporating a new part, i.e. Part 6 – Specification for Powered Vertical Lifting Platforms.

The changes have been provided for in Amendment No. 11 to the Design Code. A copy of which is attached herewith for reference. Part 6 of the Design Code shall be effective commencing March 12, 2007. Please note that the approval-in-principle for vertical lifting platforms, granted to registered lift contractors, which were not based on Part 6 of the Design Code shall lapse when the new part is brought into force. However, there will be a grace period of 18 months from the aforementioned effective date.

During the grace period, new installations of powered vertical lifting platforms of the models approved but not based on the specifications mentioned in Part 6 may continue provided that corresponding exemptions have been granted. Registered lift contractors may apply for re-appraisal of approval-in-principle for existing vertical lifting platform models (approved ones) to enable smooth transition and continuing installation of the equipment if the existing models fulfill the specifications under Part 6 of the Design Code.

.../ P. 2

The re-appraisal submission should cover the following,

- (i) a duly prepared data sheet showing manufacturer's details, type, model no., application range, operating parameters, etc. (a template is enclosed);
- (ii) a declaration confirming that the model of the powered vertical lifting platform concerned fully complies the requirements of Part 6 of the Design Code; and
- (iii) a certified true copy of the type examination certificate issued by a notified body for the powered vertical lifting platform as mentioned in Clause 8.1.1 of Part 6 of the Design Code.

In addition to the re-appraisal submissions, contractors may commence applications for approval-in-principle for new models of equipment which comply with the specifications under Part 6 by following the procedural requirements mentioned in Section C Clause 1 of the Code of Practice for Lift Works and Escalator Works. It is highly recommended that a duly completed data sheet (see the attached template) for the new model be as well provided along with the submission.

Subject to prior exemptions under section 271 of the Lifts and Escalators (Safety) Ordinance, all vertical lifting platforms with Form 5 submission made on or after September 12, 2008 shall comply with Part 6 of the Design Code.

Yours faithfully,



(CHUI Mow-wah, Gregory)  
for Director of Electrical and Mechanical Services

Encl.

c.c. AD/BS, D of Housing (Attn.: TS/2),  
D of Buildings (Attn.: CBS/Legislation), D of Fire Services (Attn.: Fire Safety Command),  
The Hong Kong General Union of Lift and Escalator Employees  
G28/28 SF1 Pt. IV

<b>Data Sheet of Powered Vertical Lifting Platform</b>			
<b>Registered Lift Contractor:</b>		<b>Contractor No.:</b>	
<b>Details of Equipment</b>			
Manufacturer:			
Address of Manufacturer:			
Model of Vertical Lifting Platform:			
Type (drive principle):			
Actuation (direct/indirect):			
Type Examination Certificate No.: (issued date)			
Max. Rated Load, kg			
Max. Rated Speed, m/s			
Max. Travel, m			
<b>Landing Door Locking Device</b>			
Manufacturer:			
Address of Manufacturer:			
Model/Type:			
Contacts Rating (volts/amperes):			
Type Examination Certificate No.: (issued date)			
<b>Safety Gear</b>			
Manufacturer:			
Address of Manufacturer:			
Maximum Load, kg			
Maximum Tripping Speed, m/s			
Type Examination Certificate No.: (issued date)			

*(The template can be expanded to have more rows and columns to suit requirements.)*

**Code of Practice  
on the Design and Construction of  
Lifts and Escalators  
(2000 Edition)**

**Amendment No. 11 of 2000 Edition  
Specification for Powered Vertical Lifting Platforms  
(Effective March 12, 2007 with a grace period of 18 months)**

## Section E

## Part 6 Specification for Powered Vertical Lifting Platforms

## Contents

	<b>Page</b>	
<b>1</b>	<b>LIFT WELL</b>	<b>1</b>
1.1	GENERAL PROVISIONS	1
1.2	LIFT OPERATION SUBJECT TO CLOSURE OF INSPECTION AND EMERGENCY DOORS AND INSPECTION TRAPS	2
1.3	CONSTRUCTION OF THE WALLS OF LIFT WELLS AND LANDING DOORS	2
1.5	HEADROOM AND PIT	2
1.5.1	Top Clearances	2
1.5.1.1	Platform Overhead Runby	2
1.5.4	Stopping Devices and Socket Outlet in the Pit	2
1.5.5	Mechanical Blocking Device in the Pit	2
1.6	EXCLUSIVE USE OF THE LIFT WELL	3
1.7	VENTILATION AND LIGHTING OF THE LIFT WELL	3
<b>2</b>	<b>MACHINE AND CONTROLLER SPACE</b>	<b>3</b>
2.1	GENERAL PROVISIONS	3
<b>3</b>	<b>LANDING DOORS</b>	<b>4</b>
3.1	GENERAL PROVISIONS	4
3.2	STRENGTH OF DOORS AND THEIR FRAMES	4
3.2.1	Material	4
3.2.2	Mechanical Strength	4
3.3	HEIGHT AND WIDTH OF DOORS	5
3.3.1	Height	5
3.3.2	Width	5
3.4	SILLS	5
3.5	PROTECTION DURING DOOR/GATE OPERATION	6
3.5.1	General Provisions	6
3.5.2	Automatic Power Operated Horizontally Sliding Doors	6
3.5.2.1	Closing Force and Kinetic Energy	6
3.5.3	Manually Controlled Power Operated Horizontally Sliding Doors	6
3.5.5	Other Types of Doors	6
3.6	LOCAL LIGHTING AND LANDING DOOR VISION PANELS	7
3.6.1	Lighting at Landings	7
3.6.2	Vision Panels for Landing Doors with Manual Opening	7
3.7	LOCKING AND CLOSED LANDING DOOR AND RAMP CHECK	7
3.7.1	Protection against the Risk of Falling	7
3.7.2	Protection against Shearing	8
3.7.3	Effective Locking and Electrical Devices for Proving the Landing Door Locked	8
3.7.4	Emergency Unlocking	8
3.7.5	Electrical Device for Proving the Landing Door Closed	8
3.7.6	Requirements Common to Devices for Proving the Locked Condition and the Closed Condition of the Door	8

<b>4</b>	<b>LIFTING PLATFORM CARRIAGE</b>	<b>8</b>
4.1	CONFIGURATION OF THE LIFTING PLATFORM CARRIAGE	8
4.2	AVAILABLE FLOOR AREA, RATED LOAD, NUMBER OF PASSENGERS	9
4.3	MECHANICAL STRENGTH	10
4.4	TOE GUARDS	10
4.5	WARNING STRIPS	10
4.16	LIGHTING AND EMERGENCY LIGHTING AT THE VERTICAL LIFTING PLATFORM	10
4.18	SIDE PANELS, HANDRAIL AND FLOOR	11
<b>5</b>	<b>SUSPENSION, PRECAUTIONS AGAINST FREE FALL, DESCENT WITH EXCESSIVE SPEED AND CREEPING OF THE LIFTING PLATFORM</b>	<b>11</b>
5.1	TYPES OF SUSPENSION	11
5.2	NUMBER OF ROPES OR CHAINS	12
5.3	RATIO BETWEEN DIAMETER OF PULLEYS AND DIAMETER OF ROPES	12
5.4	SAFETY FACTOR OF ROPES AND CHAINS	12
5.5	ROPE AND CHAIN TERMINATION	13
5.6	DISTRIBUTION OF LOAD BETWEEN ROPES OR CHAINS	13
5.7	PROTECTION OF PULLEYS USED FOR DIVERSION AND REEVING	13
5.8	WINDING OF ROPES ON DRUM DRIVE LIFTING PLATFORMS	14
5.9	PRECAUTIONS AGAINST FREE FALL OF THE LIFTING PLATFORM, DESCENT WITH EXCESSIVE SPEED AND CREEPING	14
5.10	SAFETY GEAR	16
5.10.1	General Provisions	16
5.10.3	Tripping Method	16
5.10.5	Release	16
5.10.6	Constructional Conditions	17
5.10.7	Inclination of the Lifting Platform on Operation of Safety Gear	17
5.10.8	Electrical Checking on Operation of Safety Gear	17
5.11	CLAMPING DEVICE	17
5.11.1	General Provisions	17
5.11.3	Method of Control	17
5.11.5	Release	18
5.11.6	Constructional Conditions	18
5.11.7	Inclination of the Lifting Platform Floor on Operation of Clamping Device	18
5.11.8	Electrical Checking on Operation of Clamping Device	18
5.12	TRIPPING MEANS FOR SAFETY GEARS AND CLAMPING DEVICES	18
5.12.1	General Provisions	18
5.12.2	Tripping by Overspeed Governor	18
5.12.3	Tripping by Failure of Suspension Gear	20
5.12.4	Tripping by Safety Rope	20
5.12.5	Tripping by Downward Movement of the Lifting Platform	20
5.12.5.1	Tripping by Rope	20
5.12.5.2	Tripping by Lever	21
5.12.6	Overspeed Governor Rope and Safety Rope	22
5.14	ELECTRICAL ANTI-CREEP SYSTEM	22
<b>6</b>	<b>GUIDES, BUFFERS, FINAL LIMIT SWITCHES AND SLACK ROPE SWITCH</b>	<b>22</b>
6.1	GUIDES	22
6.1.1	General Provisions	22
6.2	BUFFERS	22
6.3	FINAL LIMIT SWITCHES	22
6.3.1	General Provisions	22

6.3.2	Control	23
6.3.3	Method of Operation	23
6.4	SLACK ROPE (OR CHAIN) SAFETY DEVICE FOR INDIRECT ACTING LIFTING PLATFORMS	24
<b>7</b>	<b>CLEARANCES BETWEEN LIFTING PLATFORM AND LIFT WELL WALLS</b>	<b>24</b>
<b>8</b>	<b>DRIVE SYSTEM AND ACCESSORIES OF THE VERTICAL LIFTING PLATFORM</b>	<b>24</b>
8.1	GENERAL PROVISIONS	24
8.1.3	Protection of Machinery	24
8.1.5	Speed	25
8.1.6	Stopping the Machine and Checking its Stopped Condition	25
8.1.6.1	For Upward Motion	25
8.1.6.2	For Downward Motion	25
8.2	MANUAL EMERGENCY OPERATION	26
8.2.1	Moving the Lifting Platform Downward	26
8.2.2	Moving the Lifting Platform Upward	26
8.6	JACK	26
8.6.2	Telescopic Jacks	27
8.6.9	Protection of the Pulley(s) on the Jack	27
8.6.10	Piping	27
8.6.11	Shut-off Valve	28
8.6.12	Non-return Valve	28
8.6.13	Pressure Relief Valve	29
8.6.14	Down Direction Valves	29
8.6.15	Rupture Valve	29
8.6.16	Restrictor (or One-way Restrictor)	30
8.6.17	Filters	30
8.6.18	Pressure Gauge	30
8.6.19	Reservoir	31
8.7	RACK AND PINION DRIVE	31
8.7.1	General Provisions	31
8.7.2	Pinion	31
8.7.3	Rack	32
8.7.4	Rack and Pinion Engagement	32
8.7.5	Guarding	32
8.8	LEADSCREW AND NUT DRIVE	32
8.8.1	General Provisions	32
8.8.2	Driving Leadscrew	32
8.8.3	Driving Nut	33
8.8.4	Leadscrew and Nut Assembly	33
8.8.5	Guarding	33
8.8.6	Safety Nut	33
8.9	CHAIN SUSPENSION DRIVE	34
8.9.1	Chainwheels	34
8.10	SCISSOR MECHANISM DRIVE	34
<b>9</b>	<b>ELECTRICAL INSTALLATIONS</b>	<b>34</b>
9.1	GENERAL PROVISIONS	34
9.2	CONTACTORS, RELAY CONTACTORS, RESIDUAL CURRENT DEVICES, COMPONENTS OF SAFETY CIRCUITS	34
9.2.1	Contactors, Relay Contactors and Residual Current Devices	34

9.2.2	Components of Safety Circuits	35
9.2.3	Stopping the Drive Machine	35
9.2.3.1	Motors Supplied Directly From A.C. Mains	36
9.2.3.2	Static Elements Drive System	36
9.2.4	Suppression of Radio and Television Interference	36
9.3	PROTECTION OF MOTORS	36
9.4	MAIN SWITCHES	37
9.5	ELECTRICAL WIRING	37
9.6	LIGHTING AND SOCKET OUTLETS	37
9.6.1	Lighting	37
9.6.2	Socket Outlets	37
9.6.3	Control of Lighting Circuits and Socket Outlets Circuits	37
9.7	BATTERY POWERED OPERATION	38
<b>10</b>	<b>ELECTRICAL PROTECTION AND CONTROLS</b>	<b>39</b>
10.1	PROTECTION AGAINST ELECTRICAL FAULTS	39
10.1.1	General Provisions	39
10.1.2	Electrical Faults	39
10.1.3	Earthing Protection	39
10.2	ELECTRICAL SAFETY DEVICES	40
10.2.1	General Provisions	40
10.2.2	Safety Contacts	41
10.2.3	Safety Circuits	42
10.2.4	Operation of Electrical Safety Devices	42
10.2.5	Control of Electrical Safety Devices	42
10.3	ELECTRICAL CONTROLS	43
10.3.1	Control of the Lifting Platform	43
10.3.1.1	Normal Operation	43
10.3.1.4	Electrical Anti-creep System	43
10.3.1.6	Lift Operation with Security/Fire Gates Installed in front of Lift Entrances	44
10.3.3	Emergency Alarm Device	44
10.3.4	Priorities and Signals	44
10.4	ELECTRICAL SAFETY DEVICES USED IN THE LIFTING PLATFORM	45
<b>11</b>	<b>NOTICES AND OPERATING INSTRUCTIONS</b>	<b>46</b>
11.1	GENERAL PROVISIONS	46
11.2	AT THE LIFTING PLATFORM	46
11.2.1	Rated Load and Number of Passengers	46
11.2.2	Manufacturer	46
11.2.3	Control Devices on Lifting Platform Operating Panels	47
11.2.4	Other Necessary Instructions	47
11.2.5	Notice to Close Doors	47
11.3	ON THE CEILING	47
11.4	MACHINE AND CONTROLLER SPACE	47
11.4.1	Notices for Power Switches	47
11.4.2	Instructions for Emergency Operations	48
11.4.3	Stopping Devices	48
11.4.4	Lifting Beam or Hook	48
11.4.5	Electrical Anti-Creep System	48
11.5	ON THE LANDINGS	48
11.6	ON THE OVERSPEED GOVERNOR	49
11.7	IN THE PIT	49



## Section E Part 6

11.9	LANDING IDENTIFICATION	49
11.10	ELECTRICAL IDENTIFICATION	49
11.11	ALARM DEVICE	49
11.12	LOCKING DEVICES	49
11.13	SAFETY GEAR	49
11.14	EMERGENCY LOWERING VALVE	49
11.15	HAND PUMP	49

## 1 Lift Well

### 1.1 General Provisions

1.1.1 The platform, ram, leadscrew, guides and suspension of a powered vertical lifting platform shall be installed in a lift well.

When the lift well is required to contribute to the protection of the building against the spread of fire, it shall be totally enclosed and comply with the relevant provisions of Building (Planning) Regulations (Chapter 123), Building (Construction) Regulations (Chapter 123), the Code of Practice on Building Works for Lifts and Escalators and the Code of Practice for Fire Resisting Construction issued by the Building Authority.

When the lift well is not required to contribute to the protection of the building against the spread of fire, it does not need to be totally enclosed. The walls of the lift well may be formed from non-fire rated panels which have a mechanical strength such that when a force of 300 N being evenly distributed over an area of 500 mm<sup>2</sup> in round or square section, is applied at right angles to the wall, at any point, from the inside of the lift well towards the outside, the wall shall :

- (a) resist without any permanent deformation; and
- (b) resist without elastic deformation greater than 10 mm.

The enclosure of the vertical lifting platform shall be imperforate.

If the travel of the lifting platform exceeds 1.98 m, the lift well shall be made up of four side walls and a floor. The height of enclosure shall be of minimum 2.5 m above the upper landing or with full height to the ceiling. In no cases moveable parts other than the landing door of the lifting platform shall be reachable by a person standing outside the enclosure with the landing door fully closed.

1.1.2 If the travel of the lifting platform exceeds 1.1 m but does not exceed 1.98 m, the enclosure forming the lift well may terminate at a height of not less than 1.1 m above the upper landing.

1.1.3 If the travel of the lifting platform does not exceed 1.1 m, enclosure other than for the platform underside protection is not required.

Skirt guard may be provided instead of rigid enclosure for lifting platform the travel of which does not exceed 0.6 m to prevent hazard due to the descending platform.

1.1.4 Where hydraulic ram is used for the raising and lowering of the lifting platform, insertion of the ram into the ground or other structural cavity should be avoided.

1.1.5 The vertical travel of a powered lifting platform shall in no circumstances exceed 4.0 m.

1.1.6 The lift pit shall have a floor strength of not less than 250 kg/m<sup>2</sup>.

**1.2 Lift Operation Subject to Closure of Inspection and Emergency Doors and Inspection Traps**

See Part 1 Clause 1.2

**1.3 Construction of the Walls of Lift Wells and Landing Doors**

See Part 1 Clause 1.3

1.4 Not Used

**1.5 Headroom and Pit**

**1.5.1 Top Clearances**

**1.5.1.1 Platform Overhead Runby**

When the platform is in its fully ascended position, achieved by means of ram stroke limitation according to Clause 8.6.6 for a hydraulic powered lifting platform, or the final limit switch/stopper of a leadscrew and nut drive system or other drive systems, the following conditions shall be satisfied at the same time.

- (a) The platform guide lengths shall be such as would accommodate a further guided travel of at least 0.1 m;
- (b) The free vertical distance above the platform floor shall be not less than 2 m; and
- (c) The free vertical distance between the lowest part of the roof of the well and the highest piece of equipment attached to the lifting platform shall be at least 0.3 m.

1.5.2 Not Used

1.5.3 Not Used

**1.5.4 Stopping Devices and Socket Outlet in the Pit**

See Part 1 Clause 1.5.4

**1.5.5 Mechanical Blocking Device in the Pit**

1.5.5.1 The lifting platform shall be provided with a mechanical blocking device in the lift pit such that when the mechanical blocking device is set to operate the

running of the lifting platform drive unit will be stopped by means of an electrical safety device.

1.5.5.2 The mechanical blocking device shall be capable of supporting the platform with its rated load and obstructing the platform from descending to below 1 m as measured from the floor, for lifting platforms having a travel exceeding 1.1 m, to allow works in the lift pit to be safely carried out.

1.5.5.3 Where the travel of the lifting platform exceeds 0.6 m but does not exceed 1.1 m and the maintenance and checking of components can be performed within the lift well while the lifting platform is fully descended, the requirements under Clause 1.5.5.2 can be omitted. Otherwise, the vertical clearance below the platform by application of the mechanical blocking device shall be not less than 500 mm.

## **1.6 Exclusive Use of the Lift Well**

Part 1 Clause 1.6 shall apply. In addition, it shall be such that the lifting platform and pit equipment, as well as electrical cables, etc., are protected as far as possible from adverse impacts including water, dust, harmful fumes and humidity.

## **1.7 Ventilation and Lighting of the Lift Well**

1.7.1 The lift well formed by the enclosure shall be ventilated. A ventilation louvre of not less than 0.15 m<sup>2</sup> net free area shall be provided at the lift well for lifting platforms where,

- (a) the travel greater than 1.98 m, and
- (b) the lift well of which is not required to contribute to the protection of the building against the spread of fire.

1.7.2 The enclosure shall be provided with permanent electric lighting for illumination of the lifting platform during its normal operation. The intensity of the lighting shall be sufficient to facilitate repairs or servicing even when all the landing doors are closed.

## **2 Machine and Controller Space**

### **2.1 General Provisions**

2.1.1 The controller and their associated equipment including the drive unit of a hydraulic powered vertical lifting platform shall be installed close to the lift well. If they are installed in a room, it shall be dedicated for the vertical lifting platform and be made accessible only to authorized persons for activities such as maintenance, inspection, testing and rescue. Requirements under Part 1 Clause 2.2 shall apply by analogy.

- 2.1.2 Where the travel of the lifting platform does not exceed 1.98 m, the equipment mentioned in Clause 2.1.1 may be installed inside the enclosure forming the lift well provided that emergency lowering and raising of the lifting platform can be accomplished from outside the enclosure.
- 2.1.3 If the equipment mentioned in Clause 2.1.1 is placed in a room where machines for other lifts or escalators are installed, the stipulations under Part 1 Clause 2.1.2 also apply.
- 2.1.4 If the equipment mentioned in Clause 2.1.1 is placed away from the lift well, the hydraulic piping, where applicable, and the electric wiring connecting the drive unit with the instruments inside the lift well shall be installed in a duct or trough or in a section of a duct or trough, specially reserved for this purpose (see Clause 8.6.10.2).

### **3 Landing Doors**

#### **3.1 General Provisions**

In addition to the requirements mentioned in Part 1 Clause 3.1, the landing doors shall also be designed in accordance with the needs of persons with impaired mobility.

Where the travel of the lifting platform does not exceed 0.6 m, a ramp instead of landing door may be provided at the access edge on the lower landing side of the platform. A safety switch shall be incorporated to ensure that the ramp is in the raised position before and during ascending of the lifting platform to prevent wheelchair from slipping through the platform. The ramp shall have compatible strength as that stipulated in Clause 3.2.2 for landing door.

#### **3.2 Strength of Doors and their Frames**

##### **3.2.1 Material**

See Part 1 Clause 3.2.1

##### **3.2.2 Mechanical Strength**

Doors, with their locks, shall possess mechanical strength such that when they are in the locked position, a force of 300 N being evenly distributed over an area of 5 cm<sup>2</sup> in round or square section, is applied at right angle to the doors at any point on either face, the doors shall:

- (a) resist without permanent deformation;
- (b) resist without elastic deformation greater than 10 mm; and
- (c) operate satisfactorily after such a test.

Door panels made of glass shall comply with Clause 9.1.1.3.6 of ISO 9386-1.

If the height and/or width of the glass panel are greater than those referred to in Clause 9.1.1.3.6 of ISO 9386-1, the glass panel shall be type tested to withstand the pendulum shock tests as described in Annex J of EN 81-1 or similar international standard.

The fixing of the glass in doors shall ensure that the glass cannot slip out of the fixings, even when sinking. The glass panels shall have markings giving the name of the supplier/trade mark, type of glass and thickness/configuration.

All glass door panels shall have visual markings at level between 1400 mm and 1600 mm above the floor.

Where automatic power operated horizontally sliding doors are made up of glass panels having dimensions greater than those stated in Clause 3.6.2, means for minimizing the risk of dragging children's hands into the gaps between the glass panels and uprights shall be provided.

### **3.3 Height and Width of Doors**

#### **3.3.1 Height**

Landing door openings shall have a minimum clear height of 2 m.

If the travel of the lifting platform does not exceed 1.98 m, the height of the upper landing door can be reduced to not less than 1.1 m.

If the travel of the lifting platform does not exceed 1.1 m, gate instead of door may be provided at the upper landing. The gate shall have an upper guard rail at 0.9 – 1.1 m and an intermediate rail at 0.5 – 0.6 m above the upper landing.

#### **3.3.2 Width**

The clear width of the entrance of a lifting platform shall be not less than 900 mm if the lifting platform is installed in a location with public access.

If the lifting platform is provided only for domestic or private use, the clear width of the entrance may be reduced to not less than 800 mm. The clear width may be further reduced to not less than 650 mm for lifting platforms solely serving standing user(s).

### **3.4 Sills**

Landing door sills shall be provided in accordance with the Code of Practice on Building Works for Lifts and Escalators issued by the Building Authority.

### **3.5 Protection During Door/Gate Operation**

#### **3.5.1 General Provisions**

The doors/gates and their surrounds shall be designed in such a way as to minimize risk of damage or injury due to jamming of a part of the person, clothing or other objects.

Manual doors/gates with self-closing characteristic shall normally be provided. The force required to open a manual door/gate shall not exceed 40 N.

Gates shall be of the swing type only.

#### **3.5.2 Automatic Power Operated Horizontally Sliding Doors**

##### **3.5.2.1 Closing Force and Kinetic Energy**

The effort needed to prevent the door closing shall not exceed 150 N, measured at the closing edge and in opposite direction of the closing door.

The kinetic energy of the landing door and the mechanical elements to which it is rigidly connected, calculated or measured at the average closing speed, shall not exceed 10 J.

A sensitive protective device shall automatically initiate re-opening of the door in the event of a person being struck (or about to be struck) by the door in crossing the entrance during the closing movement.

##### **3.5.3 Manually Controlled Power Operated Horizontally Sliding Doors**

If the closing of the door is carried out under the continuous control of the users (e.g. by continuous pressure on a button) and the kinetic energy calculated or measured as laid down in Clause 3.5.2.1 exceeds 10 J, the average closing speed of the door panel(s) shall be limited to not more than 0.3 m/s.

##### **3.5.4 Not Used**

##### **3.5.5 Other Types of Doors**

When using other types of doors (e.g. hinged) with power operation, where there is a risk, when opening or closing, of striking persons, precautions similar to those laid down for other power operated sliding doors shall be taken.

Neither vertically sliding doors nor collapsible door shall be allowed for powered vertical lifting platforms.

### **3.6 Local Lighting and Landing Door Vision Panels**

#### **3.6.1 Lighting at Landings**

The lighting at landings shall comply with the minimum illumination level requirements at common area or lift lobby as stipulated in the most current version of the Design Manual – Barrier Free Access issued by the Building Authority for the design of the lighting at landings.

#### **3.6.2 Vision Panels for Landing Doors with Manual Opening**

In case of landing doors with manual opening, the user must be able to know, before opening the door, whether the lifting platform is there or not. To this effect, for landing doors having a height greater than 1.1 m there shall be installed one or more transparent vision panels conforming to the following conditions:-

- (1) mechanical strength as specified in Clause 3.2.2;
- (2) the size and shape of the vision panel shall be such that it will not permit the passage of a sphere having a diameter of 100 mm, have a minimum glazed area per landing door of 0.015 m<sup>2</sup> with a minimum of 0.01 m<sup>2</sup> per vision panel of a width of at least 60 mm;
- (3) minimum thickness of 6 mm;
- (4) the bottom edge of the vision panel shall be located between 300 mm and 900 mm above the floor level of the landing;
- (5) the vision panel shall be made of safety glass of a tempered or laminated type, or similar compatible material; and
- (6) if such door is a sliding door, the vision panel shall be flush with the surface of the door closest to the landing.

### **3.7 Locking and Closed Landing Door and Ramp Check**

#### **3.7.1 Protection against the Risk of Falling**

- (a) It shall not be possible in normal operation to unlock a landing door (or any of the panels in the case of a multi-panel door) unless the lifting platform is in the unlocking zone of that door.

It shall not be possible in normal operation to open a landing door (or any of the panels in case of a multi-panel door) unless the lifting platform is in the unlocking zone of that door.

The unlocking zone shall not extend more than 50 mm above and below the landing level.



- (b) It shall not be possible in normal operation to lower a raised ramp of the platform (with travel less than 0.6 m as stipulated in Clause 3.1) unless the lifting platform has stopped, or is on the point of stopping, in the unlocking zone at the lower landing.

### **3.7.2 Protection against Shearing**

It shall not be possible in normal operation to start the lifting platform nor to keep it in motion if a landing door (or any of the panels in the case of a multi-panel door) is open.

It shall not be possible in normal operation to start the lifting platform nor to keep it in motion outside the unlocking zone if a landing door (or any of the panels in the case of a multi-panel door) is unlocked.

### **3.7.3 Effective Locking and Electrical Devices for Proving the Landing Door Locked**

See Part 1 Clause 3.7.3

### **3.7.4 Emergency Unlocking**

See Part 1 Clause 3.7.4

### **3.7.5 Electrical Device for Proving the Landing Door Closed**

See Part 1 Clause 3.7.5

### **3.7.6 Requirements Common to Devices for Proving the Locked Condition and the Closed Condition of the Door**

See Part 1 Clause 3.7.6

## **4 Lifting Platform Carriage**

### **4.1 Configuration of the Lifting Platform Carriage**

4.1.1 The lifting platform carriage shall comprise a solid floor panel, side panels and toe guards. Within the carriage there shall be an easy grip hand rail in compliance with Clause 4.18.2, control station as mentioned in Clause 4.1.3 and necessary lighting.

4.1.2 Where the travel of the lifting platforms exceeds 0.6 m but does not exceed 1.1 m, lifting platform carriages in the configuration as stated in Clause 4.1.1 but furnished with guard rails instead of solid side panels shall also be acceptable. Clearance between the guard rails and the lift well or enclosure shall be not less than 80 mm.

- 4.1.3 If the travel of the lifting platforms is less than 0.6 m, the lifting platform carriage comprising a solid floor panel, kicker plates, toe guards, a ramp on the lower landing entrance side of the platform and a control station shall also be acceptable. The height of the toe guards and ramp shall be not less than 75 mm and 100 mm respectively. Operating devices including control buttons, emergency alarm and call button (where provided) shall be grouped to form the control station the top of which shall be at  $900 \pm 25$  mm above the platform floor and fixed on a rigid stand. A handhold shall be available at the control station to enable standing users to gain stability during operation of the lifting platform.
- 4.1.4 Apart from facilities as mentioned in Clause 4.1.1, consideration may be made to provide the lifting platform with a ceiling panel having a mechanical strength similar to that of side panels as stipulated in Clause 4.18.3. The ceiling panel shall be erected in such a way that it will not be used as a load bearing structure. In addition, the ceiling panel shall be removable to facilitate inspection and maintenance of equipment situated in the upper part of the lift way.

## 4.2 Available Floor Area, Rated Load, Number of Passengers

- 4.2.1 Vertical lifting platforms are provided for users with impaired mobility, in particular wheelchair users, to make short distance vertical travel within the premises. To provide sufficient space for a lone standing user or wheelchair user with an accompanying person, taking into account the need to cope with the orientations of the entrance/exit and configuration of landing doors/gates of the vertical lifting platform, the requirements in relation to the minimum dimensions and capacities of platforms in **Table 1** shall be observed.

**Table 1** – Minimum dimensions and capacities of lifting platforms in relation to entrance/exit arrangements

Principal User	Entrance/Exit Arrangement	Utilization	Min. Platform Dimensions		Min. Rated Load
			Width (mm)	Depth (mm)	(kg)
Lone standing user	-	-	650	650	250
User in a wheelchair	Straight through or on same side	Private use	800	1250	250
		Public access	900	1400	265
	Quarter turn	Private use / public access	1100	1400	325

- 4.2.2 Where the entry and exit are on the same side of the lifting platform, there shall be a mirror attached to the lifting platform to enable the wheelchair user to observe the path for reversing away from the lifting platform. If glass mirror is used, it shall be made of safety glass.

- 4.2.3 Notwithstanding the dimensions of the lifting platform mentioned in **Table 1**, the rated loads of vertical lift platforms shall be between 250 to 500 kg and the maximum floor area not exceeding 2 m<sup>2</sup>.

#### **4.3 Mechanical Strength**

- 4.3.1 The lifting platform assembly comprising the support frame, guide shoes, panels and floor shall have sufficient mechanical strength to resist forces arisen from normal operation, or in the operation of the safety gear, the rupture valve or the clamping device, or by the impact of a fully-laden wheelchair. The design strength of the platform shall be based on a load of not less than 210 kg/m<sup>2</sup> of the clear floor area. Unless otherwise specified, the general safety factor for all parts of the vertical lifting platform shall not be less than 1.6.

- 4.3.2 The panels, floor, roof and decorative panels etc. shall not be made of materials likely to become dangerous through too great flammability or through the nature and quantity of gas and fumes they may generate. The use of safety glass for panels and decorative panels is permitted.

#### **4.4 Toe Guards**

The platform shall be fitted under its sill with a toe guard extended to the full width of the clear landing entrance which it faces. This vertical section shall be extended downward by a chamfer whose angle with the horizontal plane shall be greater than 60°. The projection of this chamfer on the horizontal plane shall be not less than 20 mm. The height of the vertical portion of the toe guard shall be at least 75 mm.

#### **4.5 Warning Strips**

Black/yellow warning strips shall be affixed to the edges, where safety edges are not provided, of the lifting platform to alert users from keeping clear of the closing gap between moving surfaces when the lifting platform is in motion.

4.6 – 4.15 Not Used

#### **4.16 Lighting and Emergency Lighting at the Vertical Lifting Platform**

- 4.16.1 Electrical lighting shall be provided to ensure that the light intensity at the platform is compatible with that for the lift lobby as mentioned in Clause 3.6.1 and on the control devices.
- 4.16.2 See Part 1 Clause 4.16.2
- 4.16.3 Where the travel of the lifting platform exceeds 1.1 m, there shall be an emergency light of at least a 1 W lamp fed by an automatically rechargeable emergency supply which is capable of feeding the emergency lighting for at least

1 h in case of interruption to the power supply of the normal lighting. This emergency lighting shall come on automatically upon failure of the power supply to the normal lighting. The charger shall be capable of fully re-charging the batteries in not more than 12 hours.

4.17 Not Used

#### **4.18 Side Panels, Handrail and Floor**

4.18.1 The side panels of the lifting platform shall not be less than 1.1 m high. For lifting platforms having a travel not exceeding 1.1 m, side panels can be replaced by guard rails and kicker plates as mentioned in Clauses 4.1.2 and 4.1.3. The guard rails shall comprise intermediate and top rails with the top rail at about 1.1 m above the platform floor.

When the lifting platform is stopped at its topmost landing, the side panels shall not protrude from its enclosure as viewed from outside. The clearance between side panels and adjacent smooth surfaces (where no enclosure is provided) shall be not less than 120 mm.

4.18.2 Handrail where required shall be provided on one side in the form of an easy grip handrail of cross-sectional dimensions between 30 and 45 mm extending up to 150 mm away from corners. The handrail shall be installed with its top at  $900 \pm 25$  mm as measured from the floor and with the clearance between the gripping part and the side panel maintained at not less than 35 mm.

4.18.3 Each side panel of the lifting platform shall have a mechanical strength such that a force of 300 N, being evenly distributed over an area of  $500 \text{ mm}^2$  in round or square section, is applied at right angle to the panel, at any point, from the inside of the lifting platform towards the outside, the panel shall:

(a) resist without any permanent deformation; and

(b) resist without elastic deformation greater than 10 mm.

4.18.4 The platform shall be complete with anti-slip flooring.

### **5 Suspension, Precautions Against Free Fall, Descent With Excessive Speed and Creeping of the Lifting Platform**

Suspension means for indirect acting vertical lifting platforms shall comply with the requirements of Clauses 5.1 to 5.4.

#### **5.1 Types of Suspension**

5.1.1 The lifting platform shall be suspended from steel wire ropes, steel chains with parallel links (Galle type), roller chains, driving pinion or nut, or similar approved means.

5.1.2 Where the suspension of a lifting platform is achieved by wire ropes, the ropes shall have a nominal diameter of at least 5 mm. The other characteristics of the ropes (construction, extension, ovality, flexibility, tests, etc.) shall at least correspond to those specified in BS 302 : Part 1 and Part 4, or ISO 4344, or other relevant international standards.

5.1.3 The chains shall be steel plate link chains such as leaf chains complying with BS 5594 or ISO 4347; or steel roller chains complying with BS 228 or ISO 606, or other relevant international standards.

## 5.2 Number of Ropes or Chains

5.2.1 The minimum number of ropes (or chains) shall be two in the case of indirect acting vertical lifting platforms.

Ropes (or chains) shall be independent.

## 5.3 Ratio Between Diameter of Pulleys and Diameter of Ropes

The ratio between the diameter of pulleys as measured at the bottom of the rope groove and the nominal diameter of the suspension ropes shall be at least 21.

## 5.4 Safety Factor of Ropes and Chains

5.4.1 The safety factor of the suspension ropes shall be at least 12.

The safety factor is the ratio between the minimum breaking load (N) of one rope and the maximum force (N) in this rope, when the loaded platform is stationary at the lowest level. For calculation of this maximum force the following shall be taken into consideration:

- (a) the number of ropes;
- (b) the mass of the lifting platform;
- (c) the mass of the ropes; and
- (d) the rated load for the platform.

5.4.2 The safety factor of the suspension chains shall be at least 10.

The safety factor is defined in a manner analogous to that indicated in Clause 5.4.1 for ropes.

**5.5 Rope and Chain Termination**

- 5.5.1 The junction between the rope and the rope terminations, according to Clause 5.5.2, shall be able to resist at least 80% of the minimum breaking load of the rope.
- 5.5.2 The ends of the ropes shall be fixed to the lifting platform or suspension points by means of metal or resin filled sockets, self tightening wedge type sockets, heart shaped thimbles with at least three suitable rope grips, hand spliced eyes, ferrule secured eyes, or any other system with equivalent safety.
- 5.5.3 The ends of each chain shall be fixed to the lifting platform or suspension points by suitable terminations. The junction between the chain and the chain termination shall be able to resist at least 80% of the minimum breaking load of the chain.

**5.6 Distribution of Load between Ropes or Chains**

- 5.6.1 An automatic device shall be provided for equalizing the tension of suspension ropes or chains, at least at one of their ends.
- 5.6.2 If springs are used to equalize the tension they shall work in compression.
- 5.6.3 Not Used
- 5.6.4 The devices for adjusting the length of ropes or chains shall be made in such a way that these devices cannot work loose after adjustment.

**5.7 Protection of Pulleys Used for Diversion and Reeving**

- 5.7.1 Devices shall be provided to avoid:
  - (a) bodily injury;
  - (b) the ropes (or chains) leaving their grooves, if slack; and
  - (c) the introduction of objects between ropes (or chains) and grooves (or pulleys).
- 5.7.2 The devices used shall be so constructed that they do not hinder examinations, tests and maintenance operations. The dismantling of these devices shall be necessary only in the following cases:
  - (a) replacement of a rope or chain;
  - (b) replacement of a pulley; or
  - (c) re-cutting of the grooves.

## 5.8 Winding of Ropes on Drum Drive Lifting Platforms

- 5.8.1 The winding drum shall be helically grooved and the grooves shall be suited to the ropes used. The grooves shall be pitched so that there is adequate clearance between adjacent turns of rope on the drum and also between any part of rope leading onto the drum and the adjacent turn. Plain winding drums are not permitted.
- 5.8.2 When the lifting platform rests on its resilient stop on the lower landing, at least one and a half turns of rope shall remain in the grooves of the drum.
- 5.8.3 The diameter of the drum, measured at the bottom of the rope groove, shall not be less than 21 times the nominal diameter of the rope.
- 5.8.4 There shall only be one layer of rope wound on the drum.
- 5.8.5 The angle of deflection (fleet angle) of the ropes in relation to the grooves shall not exceed  $4^{\circ}$ .

## 5.9 Precautions against Free Fall of the Lifting Platform, Descent with Excessive Speed and Creeping

- 5.9.1 Devices or combinations of devices and their actuation, according to **Table 2**, shall be provided to prevent the lifting platform from:
- (a) free fall,
  - (b) descent with excessive speed, or
  - (c) creeping from a landing level by more than 50 mm for a lifting platform having a travel of more than 500 mm.
- 5.9.2 Other devices, or combinations of devices and their actuation, shall be permitted provided that they give at least the same safety level as can be achieved by those devices mentioned in **Table 2**.
- 5.9.3 For direct acting hydraulic type lifting platforms, safety gear can be omitted provided that a pressure relief valve according to Clause 8.6.13 has been provided.
- 5.9.4 Safety gear may also be omitted if the lifting platform is driven by leadscrew and nut according to Clause 8.8.

Table 2 – Combinations of precautions against free fall, descent with excessive speed and creeping of the lifting platform (Clause 5.9)

			Precaution against creeping		
			Additional tripping of safety gear (5.10) by downward movement of the lifting platform (5.12.5)	Clamping device (5.11), tripped by downward movement of the lifting platform (5.12.5)	Electrical anti-creep system (10.3.1.4)
	X: Alternative combinations to be selected				
Precautions against free fall or descent with excessive speed	Direct acting lifting platforms	Safety gear (5.10), tripped by overspeed governor (5.12.2)	X		X
		Rupture valve (8.6.15)		X	X
		Restrictor (8.6.16)		X	
	Indirect acting lifting platforms	Safety gear (5.10), tripped by overspeed governor (5.12.2)	X		X
		Rupture valve (8.6.15) plus safety gear (5.10) tripped by failure of suspension gear (5.12.3) or by safety rope (5.12.4)	X		X
		Restrictor (8.6.16) plus safety gear (5.10) tripped by failure of suspension gear (5.12.3) or by safety rope (5.12.4)	X		



## 5.10 Safety Gear

When required by Clause 5.9, safety gear provided shall satisfy the following conditions laid down in Clauses 5.10.1 – 5.10.8.

### 5.10.1 General Provisions

5.10.1.1 Not Used

5.10.1.2 The safety gear of the vertical lifting platform shall be capable of operating only during downward movement of the lifting platform and of stopping the lifting platform with the rated load even if the suspension devices break. The safety gear shall be capable of maintaining the lifting platform stationary:

- (a) when tripped by an overspeed governor which operates at its tripping speed; or
- (b) when tripped either by the failure of the suspension gear, or by a safety rope, at the speed defined in 5.10.1.4

5.10.1.3 Not Used

5.10.1.4 When a safety gear is tripped either by the failure of the suspension gear or by a safety rope, it shall be assumed that safety gear is tripped at a speed corresponding to the tripping speed of an appropriate overspeed governor.

5.10.1.5 The safety gear shall be type tested to the requirements of Appendix F.3 of BS5655 : Part 1, or EN81 : Part 1, or other relevant international standards.

5.10.2 Not Used

### 5.10.3 Tripping Method

The tripping of safety gears shall be by the means according to Clause 5.12.

The tripping of safety gears by devices which operate electrically, hydraulically or pneumatically is forbidden.

5.10.4 The safety gear shall be capable of stopping the lifting platform and holding it with its rated load in position within 150 mm from where the safety gear is actuated.

### 5.10.5 Release

When the safety gear on the lifting platform has been tripped either:

- (a) by the overspeed governor; or
- (b) by failure of the suspension; or

(c) by the safety rope,

its release shall require the intervention of a competent lift worker, and shall only be possible by raising the lifting platform.

After its release, the safety gear shall be in a condition to operate normally.

#### **5.10.6 Constructional Conditions**

It is forbidden to use the jaws or safety blocks of the safety gear as guide shoes. Adjustable components of the safety gear shall be capable of being sealed.

#### **5.10.7 Inclination of the Lifting Platform on Operation of Safety Gear**

Application of the safety gear shall not cause the lifting platform to tilt more than 5° to the horizontal.

#### **5.10.8 Electrical Checking on Operation of Safety Gear**

When the safety gear is engaged, an electric device actuated by it shall immediately initiate stopping of the machine. The electric device shall comply with the requirements of Clause 10.2.2 or 10.2.3.

#### **5.11 Clamping Device**

When required by Clause 5.9, a clamping device which satisfies the conditions laid down in Clauses 5.11.1 – 5.11.8 shall be provided.

##### **5.11.1 General Provisions**

The clamping device shall be capable of operating only during downward movement of the lifting platform at a tripping speed of not exceeding 0.3 m/s, and of stopping the lifting platform and maintaining it stationary with the rated load:

- (a) if the lifting platform has a restrictor (or one-way restrictor); or
- (b) if the lifting platform has a rupture valve.

##### **5.11.2 Not Used**

##### **5.11.3 Method of Control**

The tripping of clamping devices shall be by means according to Clause 5.12.

The tripping of clamping devices which operate electrically, hydraulically or pneumatically is forbidden.

5.11.4 The requirements of Clause 5.10.4 apply by analogy.

**5.11.5 Release**

The release of the clamping device shall require the intervention of a competent lift worker and only be possible by raising the lifting platform.

After its release, the clamping device shall be in a condition to operate normally.

**5.11.6 Constructional Conditions**

The requirements of Clause 5.10.6 apply by analogy.

**5.11.7 Inclination of the Lifting Platform Floor on Operation of Clamping Device**

The requirement of Clause 5.10.7 applies by analogy.

**5.11.8 Electrical Checking on Operation of Clamping Device**

The requirements of Clause 5.10.8 apply by analogy.

**5.12 Tripping Means for Safety Gears and Clamping Devices**

Tripping means for safety gears and clamping devices shall be provided according to the requirement of Clause 5.9.

**5.12.1 General Provisions**

The force exerted by the tripping means for the tripping of safety gear or clamping device shall be at least the greater of the two following values :

(a) either 300 N, or

(b) twice that necessary to engage the safety gear or clamping device.

**5.12.2 Tripping by Overspeed Governor**

5.12.2.1 Tripping of the overspeed governor for the lifting platform safety gear shall occur at a speed at least equal to 115% of the rated speed downwards  $V_d$  and not exceeding 0.3 m/s.

5.12.2.2 Not Used

5.12.2.3 Direction of Rotation

The direction of rotation, corresponding to the operation of the safety gear, shall be marked on the overspeed governor.

#### 5.12.2.4 Driving of the Overspeed Governor

- (a) The overspeed governor shall be driven by a rope in conformity with Clause 5.12.6. The overspeed governor rope shall be tensioned by a tensioning pulley. This pulley (or its tensioning weight) shall be guided.
- (b) During the engagement of the safety gear, the governor rope and its attachments shall remain intact, even in the case of a braking distance greater than normal. The overspeed governor rope shall be easily detachable from the safety gear.
- (c) The breakage or slackening of the governor rope shall cause the drive machine to stop by means of an electrical safety device in conformity with Clause 10.2. The device shall be of a bi-stable type.

#### 5.12.2.5 Response Time

The response time of the overspeed governor before tripping shall be sufficiently short so as not to permit a dangerous speed to be reached before the moment of safety gear operation.

#### 5.12.2.6 Accessibility

The overspeed governor shall be completely accessible in all circumstances.

#### 5.12.2.7 Test Tripping of the Overspeed Governor

During checks or tests it shall be possible to operate the safety gear by tripping the overspeed governor in some way.

#### 5.12.2.8 Sealing

The means of adjusting the overspeed governor shall be sealed after setting the tripping speed.

#### 5.12.2.9 Electrical Checking on Operation of Overspeed Governor

- (a) The overspeed governor or another device shall, by means of an electrical safety device in conformity with Clause 10.2, initiate the stopping of the drive machine at latest at the moment when the speed of the lifting platform reaches the tripping speed of the governor.
- (b) An electrical safety device in conformity with Clause 10.2 shall prevent starting of the lifting platform while the overspeed governor is in the tripped condition. This device may be in common with the device in Clause 5.12.2.9(a). Return to service of the lifting platform shall be by a competent lift worker.

### 5.12.3 Tripping by Failure of Suspension Gear

When springs are used for the tripping of the safety gear they shall be of the guided compression type.

It shall be possible to make a test, triggered from outside the well, to show that the failure of the suspension gear will trip the safety gear.

### 5.12.4 Tripping by Safety Rope

- (a) The safety rope shall be in conformity with Clause 5.12.6. The rope shall be tensioned by gravity or by at least one guided compression spring.
- (b) During the engagement of the safety gear, the safety rope and its attachments shall remain intact, even in the case of a braking distance greater than normal.
- (c) The breakage or slackening of the safety rope shall cause the machine to stop by means of an electrical safety device in conformity with Clause 10.2.
- (d) Pulleys used for carrying the safety rope shall be mounted independently of any shaft or pulley assembly that carries the suspension ropes or chains. Protection devices shall be provided in accordance with Clause 5.7.1.

### 5.12.5 Tripping by Downward Movement of the Lifting Platform

#### 5.12.5.1 Tripping by Rope

Tripping by rope of the safety gear or clamping device shall be actuated under the following conditions:

- (a) After a normal stop, a rope which satisfies Clause 5.12.6 attached to the safety gear or clamping device shall be blocked with a force defined in Clause 5.12.1.
- (b) The rope blocking mechanism shall be released during normal movement of the lifting platform.
- (c) The rope blocking mechanism shall be actuated by guided compression spring(s) and/or by gravity.
- (d) Emergency operation shall be possible in all circumstances.
- (e) An electric device associated with the rope blocking mechanism shall cause stopping of the machine at latest at the moment of blocking of the rope, and shall prevent any further normal downward movement of the lifting platform.

- (f) Precautions shall be taken to avoid involuntary tripping of the safety gear, or clamping device, by the rope in case of the disconnection of the electric power supply during a downward movement of the lifting platform.
- (g) The design of the system of rope and rope blocking mechanism shall be such that no damage is possible during the engagement of the safety gear, or clamping device, even in the case of a braking distance longer than normal.
- (h) The design of the system of rope and rope blocking mechanism shall be such that no damage is possible by an upward movement of the lifting platform.

#### 5.12.5.2 Tripping by Lever

Tripping by lever of the safety gear or clamping device shall be actuated under the following conditions :

- (a) After the normal stopping of the lifting platform, a lever attached to the safety gear, or clamping device, shall be extended into a position to engage with fixed stops, which are located at each landing.
- (b) The lever shall be retracted during the normal movement of the lifting platform.
- (c) The movement of the lever to the extended position shall be effected by guided compression spring(s) and/or by gravity.
- (d) Emergency operation shall be possible in all circumstances.
- (e) An electric device associated with the lever shall cause stopping of the machine at latest at the moment of lever extension, and shall prevent any further normal downward movement of the lifting platform.
- (f) Precautions shall be taken to avoid involuntary tripping of the safety gear, or clamping device, by the lever, in case of the disconnection of the electric power supply during a downward movement of the lifting platform.
- (g) The design of the lever and stops system shall be such that no damage is possible during the engagement of the safety gear, or clamping device, even in the case of a braking distance longer than normal.
- (h) The design of the lever and stops system shall be such that no damage is possible by an upward movement of the lifting platform.

### **5.12.6 Overspeed Governor Rope and Safety Rope**

5.12.6.1 The rope shall be a very flexible wire rope.

5.12.6.2 The breaking load of the rope shall be related by a safety factor of at least 8 for safety ropes, to the force required to operate the safety gear or clamping device.

5.12.6.3 The nominal rope diameter shall be at least 5 mm.

5.12.6.4 The ratio of the pitch diameter of the overspeed governor pulley and/or other pulleys to the nominal rope diameter shall be at least 21.

5.13 Not Used

### **5.14 Electrical Anti-creep System**

For electrical anti-creep system, see Clause 10.3.1.4.

## **6 Guides, Buffers, Final Limit Switches and Slack Rope Switch**

### **6.1 Guides**

#### **6.1.1 General Provisions**

The guides and guide fixings shall be of sufficient strength and rigidity to stop the lifting platform and its maximum safe working load on application of a safety gear or clamping device.

The lifting platform shall each be guided by at least two rigid steel guides throughout the travel which can ensure that the clearances between the edges of the lifting platform and the lift well walls/enclosure conform to Clauses 7.1 and 7.2.

### **6.2 Buffers**

Overtravel of the lifting platform at the top and bottom landings shall be limited to a maximum of 30 mm using a mechanical stop faced with a resilient material having sufficient strength to resist the driving force without permanent deformation.

### **6.3 Final Limit Switches**

#### **6.3.1 General Provisions**

6.3.1.1 A final limit switch shall be set to function as close as possible to the topmost landing, without risk of accidental operation. The final limit switch shall be provided at a position to prevent further movement of the lifting platform in both directions of travel.

If there are several limit switches at the top of the well, at least one of them shall prevent movement in both directions, and this one, after operation, shall require the intervention of a competent lift worker to return the lifting platform to service.

6.3.1.2 Where a jack (Clause 8.6) is employed for the upward/downward movement of the lifting platform, the final limit switch shall operate before the ram comes into contact with its cushioned stop. The action of the final limit switch shall be maintained while the ram is in the zone of the cushioned stop.

6.3.1.3 Where a leadscrew and nut drive system (Clause 8.8) is employed for the upward/downward movement of the lifting platform, the final limit switch shall operate before the drive nut comes into contact with the mechanical stop on the leadscrew. Once actuated, the final limit switch shall not reset so long as the drive nut is in the actuation zone at the end of the leadscrew.

### **6.3.2 Control**

6.3.2.1 Separate control devices shall be used for the upper terminal stopping device and the final limit switch. The terminal switches shall be arranged to stop the lifting platform automatically within  $\pm 15$  mm of the level being served.

6.3.2.2 In the case of direct acting lifting platforms, control of the final limit switch shall be effected:

- (a) either directly by the lifting platform, the ram or the drive nut; or
- (b) by a device linked indirectly to the lifting platform, e.g. by a rope, belt or chain. In this case, breakage of, or slack in this linkage shall cause the machine to stop by means of an electrical safety device in conformity with Clause 10.2.

6.3.2.3 In the case of indirect acting lifting platforms, control of the final limit switch shall be effected:

- (a) either directly by the ram/leadscrew; or
- (b) by a device linked indirectly to the ram/leadscrew, e.g. by a rope, belt or chain. In this case, breakage of, or slack in this linkage shall cause the machine to stop by means of an electrical safety device in conformity with Clause 10.2.

### **6.3.3 Method of Operation**

6.3.3.1 The final limit switch shall be an electrical safety device in conformity with Clause 10.2 and shall, when actuated, stop the machine and keep it stopped. The final limit switch shall close automatically when the lifting platform leaves the actuation zone.



- 6.3.3.2 After the operation of the final limit switch lifting platform movement in response to calls shall no longer be possible, even in the case of the lifting platform leaving the actuation zone by creeping. The return to normal service of the vertical lifting platform shall only be effected by the intervention of a competent lift worker.

#### **6.4 Slack Rope (or Chain) Safety Device for Indirect Acting Lifting Platforms**

If the risk of slack rope (or chain) exists, an electric safety device in conformity with Clause 10.2 shall be provided. This device shall cause the machine to stop and keep it stopped when slack occurs.

### **7 Clearances between Lifting Platform and Lift Well Walls**

- 7.1 The horizontal distance between the edges of the lifting platform and the enclosure or between platform and landing door sill shall not exceed 20 mm.

## **8 Drive System and Accessories of the Vertical Lifting Platform**

### **8.1 General Provisions**

- 8.1.1 Each lifting platform shall have at least one machine of its own. Every machine, jack, pulley and other similar equipment connected with the lifting platform shall be so supported and fixed as to prevent it from becoming loose or being displaced.

The lifting platform shall be type tested to the requirements of ISO 9386-1 or other similar international standards.

- 8.1.2 Two methods of drive are permissible:

- (a) direct acting;
- (b) indirect acting

### **8.1.3 Protection of Machinery**

Effective protection shall be provided for accessible rotating parts which may be dangerous, in particular:

- (a) keys and screws in the lift well;
- (b) tapes, chains, belts;
- (c) gears, sprockets;
- (d) projecting motor shafts; and

(e) fly-ball type overspeed governors.

#### 8.1.4 Motor Run Time Limiter

8.1.4.1 A motor run time limiter shall be provided. This device shall stop the motor of the drive machine and keep it stopped when it remains energized longer than the time required for the full upward travel with rated load, plus 10 s, with a minimum of 20 s if the full travel time is less than 10 s.

8.1.4.2 The return to normal service shall only be possible by manual resetting. On restoration of the power after a supply disconnection, maintenance of the machine in the stopped position is not necessary.

#### 8.1.5 Speed

8.1.5.1 The speed  $V_s$  shall not be greater than 0.15 m/s.

#### 8.1.6 Stopping the Machine and Checking its Stopped Condition

A stop of the machine due to the termination of a direction control signal or failure of electrical supply or upon operation of an electrical safety device, in conformity with Clause 10.2, shall be controlled as detailed below.

The stopping distances shall be no greater than:

- (a) 20 mm in response to operation of a safety contact or safety circuit;
- (b) 50 mm in response to termination of a directional signal or following the failure of the electrical supply.

##### 8.1.6.1 For Upward Motion

The supply to the electric motor of the drive machine shall be interrupted by at least two independent contactors, the main contacts of which shall be in series in the motor supply circuit.

##### 8.1.6.2 For Downward Motion

The supply to the down direction valve(s) (Clause 8.6.14) for indirect acting hydraulic powered lifting platform shall be interrupted either:

- (a) by at least two independent electrical devices connected in series; or
- (b) directly by the electrical safety device, provided it is suitably rated electrically.

8.1.6.3 If whilst the lifting platform is stationary, one of the contactors has not opened the main contacts or one of the electrical devices has not opened, a further start shall be prevented, at latest at the next change in the direction of motion.

## **8.2 Manual Emergency Operation**

### **8.2.1 Moving the Lifting Platform Downward**

- 8.2.1.1 The lifting platform shall be provided with a manually operated device located in the lift well or a room as mentioned in Clause 2.1.1 allowing the lifting platform, even in the case of a power failure, to be lowered to a level where the passenger(s) can leave the lifting platform. Where the manually operated device is provided in the lift well, it shall be accessible from outside the well.
- 8.2.1.2 The lowering of the lifting platform shall not exceed its rated speed.
- 8.2.1.3 The operation of this device shall require a continual manual force.
- 8.2.1.4 This device shall be protected against involuntary action.
- 8.2.1.5 In the case of indirect acting lifting platform employing hydraulic jack for actuation, where slack rope or slack chain can occur, manual operation shall not require opening of the down direction valve when the pressure is below the minimum operating pressure.

### **8.2.2 Moving the Lifting Platform Upward**

- 8.2.2.1 A hand-pump which causes the lifting platform to move in the upward direction shall be permanently installed for every indirect acting hydraulic powered lifting platform or platform which is fitted with a safety gear or a clamping device. Instead of a hand-pump, the provision of backup battery for raising the lifting platform is also acceptable.
- 8.2.2.2 The hand-pump shall be connected to the circuit between the non-return valve or down direction valve(s) and the shut-off valve.
- 8.2.2.3 The hand-pump shall be equipped with a pressure relief valve limiting the pressure to 2.3 times the full load pressure.

8.3 – 8.5 Not Used

## **8.6 Jack**

- 8.6.1 The cylinder and the ram shall be designed such that under the forces resulting from a pressure equal to 2.3 times the full load pressure a safety factor of at least 1.7 referred to the proof stress  $R_{p0.2}$  is assured.

**8.6.2 Telescopic Jacks**

See Part 2 Clause 8.2.5.

8.6.3 Jacks under compressive loads shall be designed such that, in their fully extended position, and under the forces resulting from a pressure equal to 1.4 times the full load pressure a safety factor of at least 2.3 against buckling is assured.

8.6.4 For direct acting lifting platforms, the connection between the lifting platform and the ram (cylinder) shall be flexible, and so constructed to support the weight of the ram (cylinder) and the additional dynamic forces. The connection means shall be secured.

8.6.5 For indirect acting lifting platforms, the head of the ram (cylinder) shall be guided. However, this requirement does not apply for pulling jacks provided the pulling arrangement prevents bending forces on the ram. No parts of the ram head guiding system shall be incorporated within the vertical projection of the lifting platform.

8.6.6 Means shall be provided to stop the ram with buffered effect in such a position that the requirements of Clause 1.5.1.1 are satisfied. This limitation of stroke shall be by means of a cushioned stop forming an integral part of the jack. The design of the cushioned stop shall be such that in the case of an indirect acting lifting platform the deceleration does not result in slack rope or chain.

8.6.7 Leak and scrape fluid from the cylinder head shall be collected.

8.6.8 The jack shall be provided with an air venting device.

**8.6.9 Protection of the Pulley(s) on the Jack**

Devices shall be provided in accordance with Clauses 5.7.1 and 5.7.2. In addition, the configuration of the groove(s) and the pitch diameter of the pulley shall comply with Clause 7.4.3 of ISO 9386-1.

**8.6.10 Piping**

8.6.10.1 Piping and fittings which are subject to pressure (connections, valves etc.) shall :

- (a) be appropriate to the hydraulic fluid used;
- (b) be designed and installed in such a way to avoid any abnormal stress due to fixing, torsion or vibration; and
- (c) be protected against damage, in particular of mechanical origin.

8.6.10.2 Pipes and fittings shall be appropriately fixed and accessible for inspection.

If pipes (either rigid or flexible) pass through walls or floor they shall be protected by means of ferrules. The dimensions of the ferrules shall be sufficient to allow the dismantling, if necessary, of the pipes for inspection.

No coupling shall be sited inside a ferrule.

8.6.10.3 Rigid pipes and fittings between the cylinder and the non-return valve or down direction valve(s) shall be designed such that under the forces resulting from a pressure equal to 2.3 times the full load pressure a safety factor of at least 1.7 referred to the proof stress  $R_{p0.2}$  is assured.

8.6.10.4 Rigid pipes and fittings, if any, between the cylinder and the rupture valve shall be designed on the same pressure basis as of the cylinder.

8.6.10.5 The flexible hose between the cylinder and the non-return valve or down direction valve shall be selected with a safety factor of at least 8 relating to the full load pressure and bursting pressure.

8.6.10.6 Flexible hose and its couplings between the cylinder and the non-return valve or down direction valve shall withstand without damage a pressure of 5 times the full load pressure. This test to be carried out by the manufacturer of the hose assembly.

8.6.10.7 All flexible hoses shall be marked in an indelible manner with :-

- (a) the name of the manufacturer or the trade mark;
- (b) the test pressure; and
- (c) the date of the test.

8.6.10.8 Flexible hoses shall be fixed with a bending radius not less than that indicated by the hose manufacturer.

### **8.6.11 Shut-off Valve**

8.6.11.1 A shut-off valve shall be provided. It shall be installed in the circuit which connects the cylinder(s) to the non-return valve and the down direction valve(s).

### **8.6.12 Non-return Valve**

8.6.12.1 A non-return valve shall be provided. It shall be installed in the circuit between the pump(s) and the shut-off valve.

8.6.12.2 The non-return valve shall be capable of holding the lifting platform with the rated load at any point when the supply pressure drops below the minimum operating pressure.

8.6.12.3 The closing of the non-return valve shall be effected by the hydraulic pressure from the jack and by at least one guided compression spring and/or by gravity.

#### **8.6.13 Pressure Relief Valve**

8.6.13.1 A pressure relief valve shall be provided. It shall be connected to the circuit between the pump(s) and the non-return valve. The hydraulic fluid shall be returned to the tank.

8.6.13.2 The pressure relief valve shall be adjusted to limit the pressure to 140% of the full load pressure.

#### **8.6.14 Down Direction Valves**

8.6.14.1 Down direction valves shall be held open electrically. Their closing shall be effected by the hydraulic pressure from the jack and by at least one guided compression spring per valve.

#### **8.6.15 Rupture Valve**

8.6.15.1 When required by Clause 5.9, a rupture valve shall be provided which satisfies the following conditions:

- (a) The rupture valve shall be capable of stopping the lifting platform in the downward movement, and maintaining it stationary, in the event of failure of any part of the hydraulic circuit (excluding the jack);
- (b) The rupture valve shall be accessible for adjustment and inspection;
- (c) The rupture valve shall be either:
  - (1) integral with the cylinder;
  - (2) directly and rigidly flange-mounted;
  - (3) placed close to the cylinder and connected to it by means of short rigid pipes, having welded, flanged or threaded connections; or
  - (4) connected directly to the cylinder by threading. The rupture valve shall be provided with a thread ending with a shoulder. The shoulder shall butt up against the cylinder.

Other types of connections such as compression fittings or flared fittings are not permitted between the cylinder and the rupture valve.

### 8.6.16 Restrictor (or One-way Restrictor)

When required by Clause 5.9, a restrictor (or one-way restrictor) shall be provided which satisfies the following conditions:

- (a) In the case of a major leakage in the hydraulic system the restrictor shall prevent the speed of the lifting platform with rated load in downward movement exceeding the rated speed downward ( $V_d$ ) by more than 0.15 m/s;
- (b) The restrictor shall be accessible for inspection; and
- (c) The restrictor shall be either:
  - (1) integral with the cylinder;
  - (2) directly and rigidly flanged-mounted;
  - (3) placed close to the cylinder and connected to it by means of short rigid pipes, having welded, flanged or threaded connections; or
  - (4) connected directly to the cylinder by threading. The restrictor shall be provided with a thread ending with a shoulder. This shall butt up against the cylinder.

Other types of connections such as compression fittings or flared fittings are not permitted between the cylinder and the restrictor.

The restrictor shall be calculated to handle the capacity of the cylinder. A drain valve shall be installed to enable manual trip testing of the system instead of overloading the lifting platform. The drain valve shall be locked off or have its operating key detached to prevent inadvertent operation.

### 8.6.17 Filters

In the circuit between the tank and the pump(s), and in the circuit between the shut-off valve and the down direction valve(s), filters or similar devices shall be installed. The filter or similar device between the shut-off valve and the down direction valve shall be accessible for inspection and maintenance.

### 8.6.18 Pressure Gauge

8.6.18.1 A pressure gauge shall be provided. It shall be connected to the circuit between the non-return valve or the down direction valve(s) and the shut-off valve.

8.6.18.2 A gauge shut-off valve shall be provided between the main circuit and the connection for the pressure gauge. The connection shall be provided with an internal thread of M20 x 1.5.

### **8.6.19 Reservoir**

The hydraulic oil reservoir shall be of a closed construction incorporating a covered filler, a breather, a filter and a level gauge for checking the level of the hydraulic fluid in the reservoir.

## **8.7 Rack and Pinion Drive**

### **8.7.1 General Provisions**

8.7.1.1 The rack and pinion drive shall consist of one or more power driven rotating pinions mounted on the lifting platform to travel on a stationary rack. The drive shall have at least one pinion, one rack and two counter rollers acting on the same section of rack where the counter rollers are used to counter-react the separating force created by the meshing rack and pinion.

8.7.1.2 All rack and pinion shall be manufactured in accordance with the dimensional requirements of BS 436:Part 2 or other equivalent standards.

8.7.1.3 The rack and pinion tooth module shall be not less than,

- (a) 4 where the forces between the counter rollers (or other means) and the rack are inter-reacted directly without any other elements of the lifting platform enclosure in between;
- (b) 6 where the forces between the counter rollers (or other means) and the rack are inter-reacted indirectly via other elements of the lifting platform enclosure in between.

8.7.1.4 When there is more than one drive pinion in mesh with the rack, then either a self-adjusting means shall be provided effectively to share the loading on each drive pinion, or the drive system shall be designed to accommodate all conditions of load distribution between the pinions.

8.7.1.5 The overspeed governor pinion shall be at a position lower than the drive pinion(s).

8.7.1.6 Visual examination of the pinions shall be possible without the removal of the pinions or major disassembly.

### **8.7.2 Pinion**

8.7.2.1 The drive pinion, overspeed governor pinion and other pinions engaged with the rack shall be machined from wear resistant material and have a safety factor of not less than 6. The safety factor is equal to the ultimate tensile stress of the pinion material divided by the maximum stress exerted on the pinion. The stresses exerted in the pinion teeth shall be capable of sustaining the total



suspended load which includes the weight of the lifting platform and the rated load.

8.7.2.2 Undercutting of the teeth shall be avoided.

8.7.2.3 The pinion shall be affixed to the output shaft by positive means. Methods involving friction and clamping shall not be used.

### **8.7.3 Rack**

8.7.3.1 The rack shall be made of material having properties matching those of the pinions in terms of wear and impact strength and shall possess an equivalent safety factor.

8.7.3.2 The rack shall be securely attached to the lifting platform enclosure particularly at their ends. Joints in the rack shall be accurately aligned to avoid faulty meshing or damage to teeth.

8.7.3.3 The load imposed upon the rack by the pinion shall not cause permanent deformation of the rack.

### **8.7.4 Rack and Pinion Engagement**

8.7.4.1 Means shall be provided to maintain the rack and all the drive pinion(s) and any safety gear constantly in mesh under all load conditions. Such means shall not rely solely upon the guide rollers or shoes of the lifting platform.

8.7.4.2 Means shall be provided to restrict the disengagement of the drive pinion(s) from the rack in such a way that at least 90% of the width of a rack tooth is always engaged with the drive pinion(s) in the event of failure of a roller or shoe.

8.7.4.3 The pinion teeth and the rack teeth shall be square to each other in all planes, within a tolerance of  $\pm 0.5^\circ$ .

### **8.7.5 Guarding**

Mechanical guard(s) shall be provided to prevent trapping of foreign objects between the rack and pinion.

## **8.8 Leadscrew and Nut Drive**

### **8.8.1 General Provisions**

### **8.8.2 Driving Leadscrew**

8.8.2.1 The driving leadscrew shall be made of steel having a dimension suitable for the dynamic load anticipated for the lifting platform. The driving leadscrew shall be designed to resist wear and shall have a safety factor, based on ultimate tensile

strength and dynamic load, of not less than 5, and a safety factor of not less than 3 against buckling.

### **8.8.3 Driving Nut**

8.8.3.1 The driving nut shall be made from metal compatible with that of the leadscrew with respect to the impact strength. The selection of material shall render wear arising from the interaction between the leadscrew and the driving nut to take place on the nut side.

8.8.3.2 The driving nut shall have a safety factor similar to that of the leadscrew.

### **8.8.4 Leadscrew and Nut Assembly**

8.8.4.1 The drive to the rotating component shall be directly controlled by a brake. Chain or belt type intermediate drives are permitted if the output drive gearing shall be on the load side of the chain or belt intermediate drive, and

- (a) the output drive gearing shall be self-sustaining; or
- (b) the brake shall be on the load side of the chain or belt intermediate drive and a minimum of two belts shall be used. The chain or belt intermediate drive shall be monitored by a safety contact that shall disconnect the supply to the motor and brake in the event of breakage of any chain or belt. If V belts are used, monitoring shall also detect the slackening of any one belt.

8.8.4.2 The rotating component shall be restrained against axial or radial movement by means of adequately supported bearings. The leadscrew shall be fitted with devices at both ends to prevent the load bearing nut and safety nut from leaving the leadscrew.

### **8.8.5 Guarding**

8.8.5.1 Mechanical guard(s) shall be provided to prevent trapping of foreign objects between the leadscrew and nut assembly.

### **8.8.6 Safety Nut**

8.8.6.1 Safety nut may be used in place of a safety gear. The safety factor of the safety nut shall be analogy to that of the driving nut. The safety nut shall only be loaded if the load-bearing nut fails.

8.8.6.2 The operation of the safety nut shall trigger a safety contact in compliance with Clause 10.2 which stops and holds the fully loaded platform in position.

## **8.9 Chain Suspension Drive**

### **8.9.1 Chainwheels**

8.9.1.1 All driving chainwheels shall be made of steel and have a minimum of 16 machine-cut teeth. A minimum of 8 teeth shall be engaged. The minimum angle of engagement shall be  $140^{\circ}$ . The driving chainwheels shall be fixed to the drive shaft by positive means.

8.9.1.2 Chains used as suspension elements shall be leaf or roller type only. They shall be dimensioned in accordance with ISO 606.

8.9.1.3 The safety factor, calculated as the guaranteed total breaking load of all the chains divided by the maximum static support load, shall not be less than 10.

### **8.10 Scissor Mechanism Drive**

8.10.1 Where the travel of the lifting platform does not exceed 1.1 m, scissor mechanism drive employing hydraulic ram or leadscrew and nut driving device is acceptable.

8.10.2 The connection between the platform and the drive mechanism shall be by positive means.

## **9 Electrical Installations**

### **9.1 General Provisions**

See Part 1 Clause 9.1

### **9.2 Contactors, Relay Contactors, Residual Current Devices, Components of Safety Circuits**

#### **9.2.1 Contactors, Relay Contactors and Residual Current Devices**

9.2.1.1 The main contactors (i.e. those necessary to stop the machine as per Part 1 Clause 8.7) shall belong to the following categories as defined in IEC 60947-4-1:

- (a) AC-3 for contactors for a.c. motors.
- (b) DC-3 for contactors for d.c. motors.

9.2.1.2 If, because of the power they carry, relays must be used to operate the main contactors, those relays shall belong to the following categories as defined in IEC 60947-5-1 or other relevant international standards:

- (a) AC-15 for relays controlling a.c. contactors;

- (b) DC-13 for relays controlling d.c. contactors.
- 9.2.1.3 Each contactor specified in Clause 9.2.1.1 and Clause 9.2.1.2 shall operate such that:
- (a) if one of the break contacts (normally closed) is closed, then all the make contacts are open;
  - (b) if one of the make contacts (normally open) is closed, all the break contacts are open.
- 9.2.1.4 Contactors for reversing the direction of the travel of the lifting platform shall be electrically interlocked.
- 9.2.1.5 All electrical circuits, other than supplies to charging units on battery-operated lifting platforms, carrying a voltage greater than 55 V above earth shall be protected by the use of a residual current device (RCD) conforming to either BS4293: 1983 or BS7071: 1992 or BS7288: 1990, as appropriate, or other relevant international standards. The maximum rated tripping current shall be 30 mA. The maximum trip time at rated tripping current shall be 200 ms. The maximum trip time at 5 times the rated tripping current shall be 40 ms. The testing of this RCD shall not cause any spurious tripping of any other RCD fitted to the mains supply circuit.

## 9.2.2 Components of Safety Circuits

- 9.2.2.1 When devices as per Clause 9.2.1.2 are used as relays in a safety circuit, the assumption of Clause 9.2.1.3 shall also apply.
- 9.2.2.2 If relays are used which are such that the break and make contacts are never closed simultaneously for any position of the armature, the possibility of partial attraction of the armature (see Clause 10.1.2(f)) can be disregarded.
- 9.2.2.3 Devices (if any) connected after electrical safety devices shall meet the requirements of Clause 10.2.2.2 as regards the creep distances and the air gaps (not the separation distances).

This requirement does not apply to the devices mentioned in Clauses 9.2.1.1, 9.2.1.2 and 9.2.2.1 and which themselves fulfil the requirements of BS 5424: Part 1 or IEC 158; and EN 60947-5-1; or other relevant international standards.

## 9.2.3 Stopping the Drive Machine

The stopping of the machine by means of an electrical safety device, in conformity with Clause 10.2, shall be controlled as detailed below.

### 9.2.3.1 Motors Supplied Directly From A.C. Mains

The supply shall be interrupted by two independent contactors, the contacts of which shall be in series in the supply circuit.

### 9.2.3.2 Static Elements Drive System

One of the following methods shall be used :

- (a) Two independent contactors interrupting the current to the motor.

If, while the lifting platform is stationary, one of the contactors has not opened the main contacts, any further movement shall be prevented, at the latest at the next change in direction of motion; or

- (b) A system consisting of :

- (1) A contactor interrupting the current at all poles.

The coil of the contactor shall be released at least before each change in direction. If the contactor does not release, any further movement of the lifting platform shall be prevented;

- (2) An independent control device blocking the flow of energy in the static elements; and

- (3) A monitoring device to verify the blocking of the flow of energy each time the lifting platform is stationary.

If, during a normal stopping period, the blocking by the static elements is not effective, the monitoring device shall cause the contactor to release and any further movement of the lifting platform shall be prevented.

### 9.2.4 Suppression of Radio and Television Interference

The design of the electric motor, contact devices and control devices shall conform to BS EN 55014: 1993, or other relevant international standards. Suppression components shall not be used in any part of the circuit where their failure might cause an unsafe condition.

## 9.3 Protection of Motors

9.3.1 See Part 1 Clause 9.3.1

9.3.2 Not Used

9.3.3 See Part 1 Clause 9.3.3

**9.4 Main Switches**

See Part 1 Clause 9.4

**9.5 Electrical Wiring**

See Part 1 Clause 9.5

**9.6 Lighting and Socket Outlets**

**9.6.1 Lighting**

The supplies to the electric lighting of the lifting platform, the liftwell and the machine space shall be independent of the supply to the machine, either through another circuit or through connection to the machine supply circuit on the supply side of the main switch or the main switches laid down in Clause 9.4.

**9.6.2 Socket Outlets**

The supply to socket outlets required on the machine space and in the pit, shall be independent of the supply to the machine and can be taken from the circuits referred to in Clause 9.6.1.

These socket outlets shall be either of type 2P + PE, 250 V in accordance with BS 1363 (or other relevant international standards), or supplied at a safety extra-low voltage, in accordance with the Code of Practice for the Electricity (Wiring) Regulations issued under the Electricity Ordinance.

The use of the above socket outlets to BS 1363 (or other relevant international standards) does not imply that the supply cable has a cross-sectional area corresponding to the rated current of the socket outlet. The cross-sectional area of the conductors may be smaller, provided that the conductors are correctly protected against excess currents.

**9.6.3 Control of Lighting Circuits and Socket Outlets Circuits**

9.6.3.1 A switch shall control the supply to the circuit of each lifting platform. If the machine space/room contains several lift machines it is necessary to have one switch per each lift car and lifting platform. It shall be clearly marked with the equipment identification and its purpose.

9.6.3.2 A switch shall control the supply to the lighting and socket outlet circuit of each machine space. This switch shall be located inside and close to the access to the machine space. It shall be clearly marked with its purpose.

9.6.3.3 A switch shall control the supply to the circuit of each well and pit. This switch shall be located inside and close to the access to the machine space. It shall be clearly marked with the equipment identification and its purpose.

- 9.6.3.4 Each circuit controlled by the switches laid down in Clauses 9.6.3.1, 9.6.3.2 and 9.6.3.3 shall have its own protection.

## 9.7 Battery Powered Operation

- 9.7.1 Battery powered lifting platform may be of the type that can be automatically rechargeable.

- 9.7.2 Batteries shall not leak when tilted and battery enclosures shall be ventilated. The battery charger shall not damage or overcharge the batteries, even after long periods on charge.

The batteries shall not emit fumes during normal operation including charging.

- 9.7.3 A fuse shall be fitted in line with the battery supply which shall only be accessible by the use of an appropriate tool(s). This fuse shall isolate the battery supply within 0.5 s of the supply being short circuited and within 5 s of twice average peak current being drawn.

- 9.7.4 The charging arrangement for the batteries shall typically be as shown in **Fig. 1a** for a.c. charging and **Fig. 1b** for d.c. charging. The maximum voltage potential when measured with respect to earth shall be 220 V a.c. or 55 V d.c. for protected charge contacts and 24 V a.c. or 55 V d.c. for exposed charge contacts.

Charge contacts are deemed to be exposed when they are accessible without the use of tools, and protected where it is not possible to touch the contacts without the use of tools.

Battery charging should be carried out at points where the lifting platform is expected to be stationary between journeys. Usually this is at each end of the rail.

- 9.7.5 Battery terminals shall be physically protected against short circuiting.

- 9.7.6 Batteries shall be securely fixed.

- 9.7.7 The control circuit voltage of the lifting platform shall not exceed 55 V.

- 9.7.8 Batteries shall have a life of at least three years in normal use.

- 9.7.9 The battery shall be capable of being isolated from the circuit by use of a switch fitted to the lifting platform which shall be accessible and operable without the use of a tool.

- 9.7.10 The battery capacity and charging rate shall be appropriate to the conditions of service of the lifting platform.

- 9.7.11 If the lifting platform is brought to rest out of the reach of the charge

contacts, this shall be indicated to the passenger.

9.7.12 The carriage chassis shall be grounded as shown in **Fig. 1**.

## **10 Electrical Protection and Controls**

### **10.1 Protection Against Electrical Faults**

#### **10.1.1 General Provisions**

Any one of the faults envisaged in Clause 10.1.2 in the electrical equipment of the vertical lifting platform shall not, on its own, be the cause of a dangerous malfunction of the installation.

#### **10.1.2 Electrical Faults**

The following faults are envisaged in the electrical equipment of the vertical lifting platform:

- (a) absence of voltage;
- (b) voltage drop;
- (c) loss of continuity of a conductor,
- (d) insulation fault in relation to the metalwork or the earth;
- (e) short circuit or open circuit, change of value or function in an electrical component such as resistor, capacitor, transistor, lamp;
- (f) non-attraction or incomplete attraction of the moving armature of a contactor or relay;
- (g) non-separation of the moving armature of a contactor or relay;
- (h) non-opening of a contact;
- (i) non-closing of a contact; or
- (j) phase reversal.

The non-opening of a contact in case (h) need not be considered in the case of safety contacts conforming to the requirements of Clause 10.2.2.

#### **10.1.3 Earthing Protection**

When a circuit in which there is an electrical safety device in conformity with Clause 10.2 is short-circuited to earth as in case (d) in Clause 10.1.2, it shall cause the immediate stopping and prevent restarting of the lifting platform.



The return to service of the lifting platform shall not be possible except by a competent lift worker.

## 10.2 Electrical Safety Devices

### 10.2.1 General Provisions

10.2.1.1 During operation of one of the electrical safety devices listed in Clause 10.4, movement of the drive machine shall be prevented or it shall be caused to stop immediately as indicated in Clause 10.2.4. The electrical safety devices shall consist of:

- (a) either one or more safety contacts satisfying Clause 10.2.2 directly cutting the supply to the contactors referred to in Clause 8.1.6 or their relay contactors; or
- (b) either one or more safety contacts satisfying Clause 10.2.2 not directly cutting the supply to the contactors referred to in Clause 8.1.6 or their relay contactors in conjunction with a safety circuit satisfying Clause 10.2.3.

10.2.1.2 Apart from exceptions permitted in this Code, no electrical equipment shall be connected in parallel with an electrical safety device.

10.2.1.3 The effects of internal or external induction or capacity shall not cause failure of electrical safety devices.

10.2.1.4 An output signal emanating from an electrical safety device shall not be altered by an extraneous signal emanating from another electrical device placed further down the same circuit or from telecommunication cabling and signal transmission devices installed in the vicinity, which would cause a dangerous condition to result.

10.2.1.5 In safety circuits comprising two or more parallel channels, all information other than that required for parity checks shall be taken from one channel only.

10.2.1.6 Circuits which record or delay signals shall not, even in event of fault, prevent or appreciably delay the stopping of the drive machine through the functioning of an electrical safety device.

10.2.1.7 The construction and arrangement of the internal power supply units shall be such as to prevent the appearance of false signals at outputs of electrical safety devices due to the effects of switching.

In particular, voltage peaks arising from normal operation of the lifting platform or other equipment on the network shall not create inadmissible disturbances in electronic components (noise immunity).

## 10.2.2 Safety Contacts

### 10.2.2.1 Positive Separation of Contacts

The operation of a safety contact shall be by positive separation of the circuit-breaking devices. This separation shall occur even if the contacts have welded together.

Positive separation is achieved when all the contact-breaking elements are brought to their open position and when for a significant part of the travel there are no resilient members (e.g. springs) between the moving contacts and the part of the actuator to which the actuating force is applied.

The design shall be such as to minimize the risk of a short-circuit resulting from component failure.

### 10.2.2.2 Type of Safety Contacts and Protective Enclosure

The safety contacts shall be provided for a rated insulation voltage of 250 V if the enclosure provides a degree of protection of at least IP 4X, or 500 V if the degree of protection of the enclosure is less than IP 4X, in accordance with BS 5490; or IEC 529 or other relevant international standards.

The safety contacts shall belong to the following categories as defined in EN 60947-5-1 or other relevant international standards :

- (a) AC-15, for safety contacts in ac circuits.
- (b) DC-13, for safety contacts in dc circuits.

If the degree of protection is equal to or less than IP 4X, the clearance shall be at least 3 mm, the creep distances at least 4 mm and the distances for breaching contacts at least 4 mm after separation. If the protection is better than IP 4X the creep distance can be reduced to 3 mm.

Under extreme conditions of external influence, the live parts of safety contacts shall be accommodated in an appropriate protective enclosure. However, protective enclosure need not be provided in the case of external influences considered as normal in the Code of Practice for the Electricity (Wiring) Regulations issued under the Electricity Ordinance or the Regulations for Electrical Installation by the Institution of Electrical Engineers.

In the case of multiple breaks, the distance after separation between the contacts shall be at least 2 mm.

Abrasion of conductive material shall not lead to short circuiting of contacts.

### 10.2.3 Safety Circuits

Safety circuits shall comply with the requirements of Clause 10.1.1 relating to the appearance of a fault. In addition, it shall be designed such that :

- (a) If a dangerous situation can only occur through the combination of several faults, the stopping and maintaining in a stopped position of the lifting platform shall be brought about at the latest at the next change of direction if the possible appearance of a further fault which, in conjunction with the already existing faults, would lead to the dangerous situation.

However, a combination of more than three faults can be disregarded if the safety circuit is built out of at least two channels. In the case of different status, the lifting platform shall be stopped at latest at the next change of direction.

- (b) On restoration of the power supply after it has been disconnected, maintenance of the lifting platform in the stopped position is not necessary, provided that during the next sequence stopping is re-imposed in the cases covered by Clause 10.2.3(a).

### 10.2.4 Operation of Electrical Safety Devices

When operating to ensure safety, an electrical safety device shall prevent the setting in motion of the drive machine or initiate immediately its stopping. The electrical supply to the drive machine, brake and direction valves (where appropriate) shall likewise be broken.

The electrical safety devices shall act directly on the equipment controlling the supply to the machine in accordance with the requirements of Clause 8.1.6.

If, because of the power to be transmitted, relay contactors are used to control the drive machine, these shall be considered as equipment directly controlling the supply to the drive machine for starting and stopping.

### 10.2.5 Control of Electrical Safety Devices

The components controlling the electrical safety devices shall be built so that they are able to function properly under the worst case limits and within manufacturer's recommendations for voltage, current and duty.

If the devices for controlling electrical safety devices are through the nature of their installation accessible to persons, they must be so built that these electrical safety devices cannot be rendered inoperative by simple means. A magnet or a bridge piece is not considered a simple means.

### 10.3 Electrical Controls

#### 10.3.1 Control of the Lifting Platform

Control shall be effected electrically as stated in Clauses 10.3.1.1 – 10.3.1.6.

##### 10.3.1.1 Normal Operation

Control shall be by the aid of buttons. These shall be placed in boxes, such that no live parts are accessible.

The movement of the lifting platform shall be dependent on a constant pressure on the push-button or spring-biased toggle devices that positively return to the off position when released protected against accidental operation and with the direction of movement clearly indicated on the button. All up and down control switches shall be electrically interlocked. Release of the constant pressure switch shall cause immediate removal of the power supply to the brake and driving motor.

A bi-stable isolating safety switch shall be fitted on the lifting platform which, when operated, directly activates the safety circuit. This switch is also intended as a holding switch to control the movement of the lifting platform.

Control limit switches operated by the movement of the lifting platform shall be provided to stop it automatically at the normal floors/storeys served.

If springs are used to actuate switches, contactors or relays to break the circuit to stop the lifting platform at the terminal landing, they shall be of the restrained compression type.

##### 10.3.1.2 Not Used

##### 10.3.1.3 Not Used

##### 10.3.1.4 Electrical Anti-creep System

When required by Clause 5.9, an electrical anti-creep system shall be provided, which satisfies the following conditions :

- (a) The machine shall be energized in the up direction independent of the position of the doors, when the lifting platform is in a zone which extends from maximum 40 mm below the landing level to the lower end of the unlocking zone;
- (b) When the lifting platform has been unused for a period not exceeding 15 min after the last journey, the lifting platform shall be dispatched automatically to the lowest landing;

(c) Indications according to Clauses 11.2.5 and 11.4.5 shall be provided.

10.3.1.5 Not Used

**10.3.1.6 Lift Operation with Security/Fire Gates Installed in front of Lift Entrances**

See Part 1 Clause 10.3.1.6

10.3.2 Not Used

**10.3.3 Emergency Alarm Device**

Requirements under Part 1 Clause 10.3.3 shall apply except that where the travel of the lifting platform does not exceed 1.98 m, intercom and CCTV may be omitted.

**10.3.4 Priorities and Signals**

For lifting platforms with manual doors, a device shall prevent the lifting platform from leaving a landing for a period of at least 2 seconds after stopping.

A user who enters the lifting platform shall have at least 2 seconds after the doors have closed, to enable him/her to press the button of his/her choice before any external call buttons can become effective in determining the direction of travel. Control at the lifting platform shall override control at the landing control station.

## 10.4 Electrical Safety Devices Used in the Lifting Platform

Table 3 shows the electrical safety devices to be used in a lifting platform.

**Table 3**  
Electrical Safety Devices of Lifting Platforms

Clause	Function
1.2	Check on closed position of inspection and emergency doors and inspection traps
1.5.5.1	Check on position of blocking device
3.1	Check on position of lower entrance ramp
3.7.3	Check on locking of landing doors
3.7.5	Check on closed position of landing doors
5.10.8	Check on the operation of safety gear
5.11.8	Check on the operation of clamping device
5.12.2.4	Check for breakage or slackening of governor rope
5.12.2.9	Operation of overspeed governor
5.12.4	Check for breakage or slackening of safety rope
5.12.5.1	Check for status of rope slacking mechanism
5.12.5.2	Operation of safety gear or clamping device
6.3.2.2	Check for breakage or slackening of platform over-travel monitoring linkage for direct acting lifting platform
6.3.2.3	Check for breakage or slackening of platform over-travel monitoring linkage for indirect acting lifting platform
6.3.3.1	Final limit switch
6.4	Check for slack rope or slack chain
8.8.4.1	Check for chain or belt intermediate drive status
8.8.6.2	Operation of safety nut
9.2.3	Stopping devices
10.3.1.1	Stopping device

**11 Notices and Operating Instructions**

**11.1 General Provisions**

See Part 1 Clause 11.1

**11.2 At the Lifting Platform**

**11.2.1 Rated Load and Number of Passengers**

A notice, similar to the sample attached below, showing the rated load of the lifting platform in kilograms as well as the category of users, where applicable, should be permanently fixed to the lifting platform. The height of the inscriptions of the notice shall be not less than 10 mm.

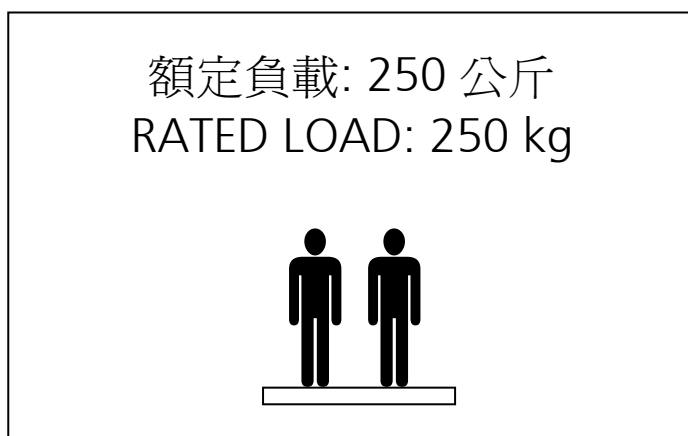

**11.2.2 Manufacturer**

See Part 1 Clause 11.2.2

### 11.2.3 Control Devices on Lifting Platform Operating Panels

Stopping device and control switches for upward and downward movement of the lifting platform shall be provided and conform to Clause 10.3.1.1. They shall be located at height and in such a way as mentioned in Clause 10.3.3.

The alarm button shall be yellow in colour and identified by the symbol:



The above stopping device, control switches and alarm button shall be located on the armrest(s) for easy and safe operation if the lifting platform serves also wheelchair users.

Appropriate notices or labels (in Chinese and English) shall be displayed next to all the devices to indicate the function and/or operation of them.

### 11.2.4 Other Necessary Instructions

See Part 1 Clause 11.2.4

### 11.2.5 Notice to Close Doors

In the case of a lifting platform provided with an electrical anti-creep system and with manually operated doors, or with power operated doors where closing is carried out under the continuous control of the users, there shall be a notice in the lifting platform as follows:

'CLOSE DOORS AFTER USE'  
( 用後關門 )

The minimum height of the characters shall be 50 mm.

## 11.3 On the Ceiling

Where a ceiling is fitted, a label giving warning that the ceiling is not load bearing and warning against treading on the ceiling shall be provided.

## 11.4 Machine and Controller Space

### 11.4.1 Notices for Power Switches

See Part 1 Clause 11.4.1



#### 11.4.2 Instructions for Emergency Operations

In the machine and controller space or the interior of the controller, there shall be detailed instructions to be followed in the event of breakdown of the lifting platform, particularly concerning the use of the device(s) for manual emergency movement, and the unlocking key for landing doors.

#### 11.4.3 Stopping Devices

On or near any stopping devices in the machine and controller space there shall be the word 'STOP' ( 停止 ) so placed that there can be no risk of error as to the stop position (see Part 1 Clause 2.2.4).

#### 11.4.4 Lifting Beam or Hook

See Part 1 Clause 11.4.4

#### 11.4.5 Electrical Anti-Creep System

In the case of a lifting platform provided with an electrical anti-creep system there shall be an inscription on or near the main switch:

'Switch off only when the lifting platform is at the lowest landing'.  
( 待升降平台到達最低樓層方可關掉 )

### 11.5 On the Landings

Manually operated landing doors, if they can be confused with other adjacent doors, shall bear the inscription 'LIFTING PLATFORM' ( 升降平台 ).

Each of the landing doors, or walls adjacent to the landing doors, shall display the instructions as required in Part 1 Clause 11.2.4(f). In addition, each of the landing doors, or walls adjacent to the landing doors shall be affixed with a label of tear-resistant durable material showing the international symbol for access for persons with a disability as illustrated in the most current version of the Design Manual – Barrier Free Access issued by the Building Authority.

Control switches for calling the lifting platform shall be provided at each landing (upper, intermediate and lower) and conform to Clause 10.3.1.1. They shall be located at a height and in such a way as mentioned in Clause 10.3.3.

Provisions shall be made at all landings for warning indication to be displayed to inform others that the lift is out of service for maintenance. The display of such indication or the illumination of such indicator shall be controlled by a manually operated switch and additionally may be switched on automatically. The indication shall bear the inscription "OUT OF SERVICE" (minimum height 8 mm) and "暫停" (minimum height 12 mm).

**11.6 On the Overspeed Governor**

See Part 1 Clause 11.6

**11.7 In the Pit**

See Part 1 Clause 11.7

**11.8 Not Used**

**11.9 Landing Identification**

See Part 1 Clause 11.9

**11.10 Electrical Identification**

See Part 1 Clause 11.10

**11.11 Alarm Device**

See Part 1 Clause 11.11

**11.12 Locking Devices**

See Part 1 Clause 11.12

**11.13 Safety Gear**

See Part 1 Clause 11.13

**11.14 Emergency Lowering Valve**

Near the manually operated valve for emergency downward movement there shall be a plate stating:

'Caution - Emergency Lowering'  
( 小心 - 緊急下降 )

**11.15 Hand Pump**

Near the hand pump for emergency upward movement there shall be a plate stating:

'Caution - Emergency Lifting'  
( 小心 - 緊急上升 )

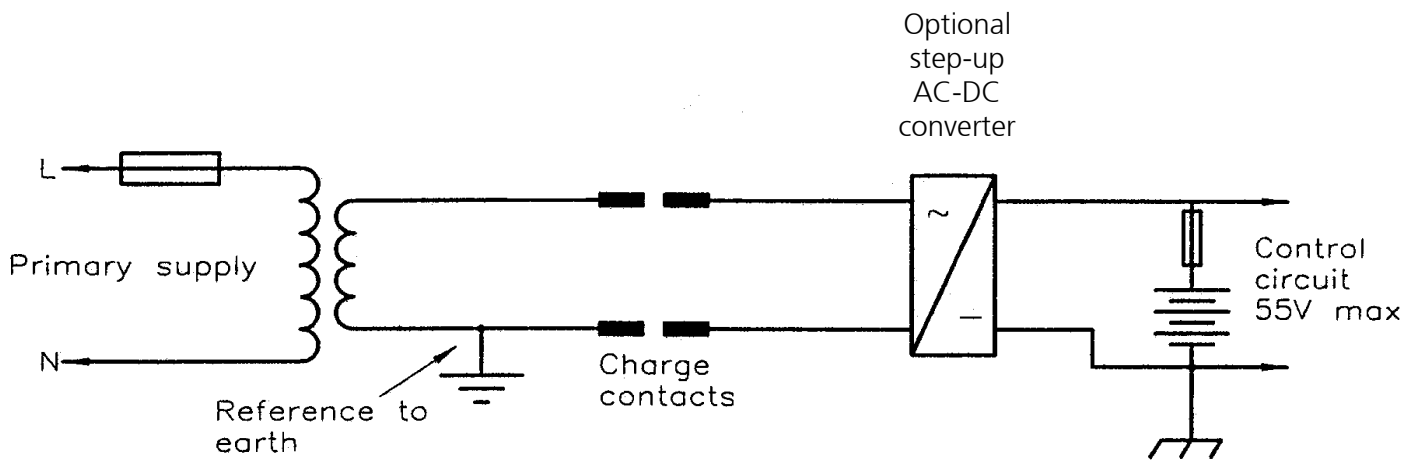

a) AC charge contacts

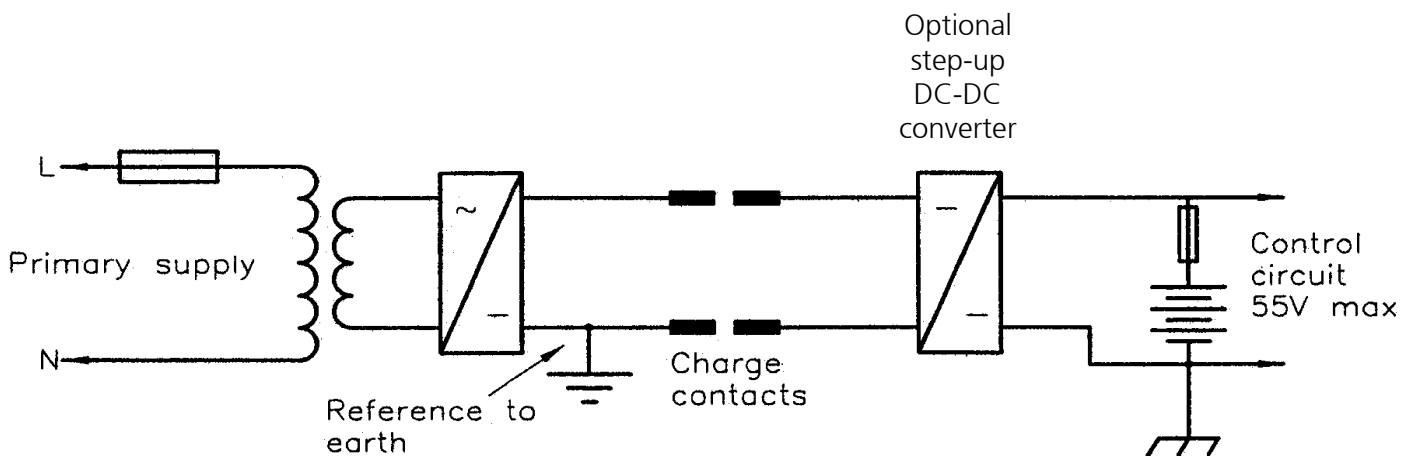

b) DC charge contacts

Fig. 1 Typical charging supply circuit for battery powered operation