

Our reference 本署檔號 :

(101) in LE/02/04 Pt. II

Telephone 電話號碼: 2808 3861

Your reference 來函檔號 :

Facsimile 圖文傳真: 2504 5970

April 25, 2003

All Registered Lift and Escalator Contractors

Dear Sirs,

**Circular No. 8/2003**

**Log-book of Lift/Escalator Works**

After consulting the trade's representatives, the content pages of the log-book of lift/escalator works, which was proposed in 1987 under the circular letter ref. (117) in EM/LE/55, shall have the following amendments (*see attached sample sheet*):

- (1) exclusion of "Contractor Called" (*this information should be logged separately by the contractor and shall be available on request*);
- (2) sub-dividing "Type of Work" into "Breakdown", "Trapping" and "Routine" (*under column (2)*);
- (3) addition of date and time in respect of releasing passenger(s) (*under column (4)*);  
and
- (4) implementation of a signing system using both Chop (*with easy identification, see attached samples for reference*) and Signature (*under column (7)*).

It is understood that time is required for preparing the above changes. In this connection, the commencement date of using the new log-book shall be **January 1, 2004**. Nevertheless, starting from **June 1, 2003**, if existing log-books are still in use, the engineer/worker attending site should record all newly required data into the log-book by handwriting.

Also, please be reminded that the responsible engineer/worker attending site should enter the details of lift/escalator works done correctly and precisely into the log-book and confirm the entry by signing and chopping their names on the log-book. It is worth bearing in mind that every engineer/worker shall keep his own chop which should not be used by others.

Since it is required by the Lifts and Escalator (Safety) Ordinance that the Log-book of lift/escalator works shall be kept and maintained by the lift/escalator owner, you are requested to notify the owners of lifts/escalators under your maintenance of the above changes and new requirements.

Yours faithfully,

(LAW Yu-wing)  
for Director of Electrical and Mechanical Services

Encl.

c.c. The Director of Housing  
The Director of Architectural Services  
The Lift and Escalator Contractors Association  
The Registered Elevator and Escalator Contractors Association Ltd.  
The International Association of Elevator Engineers  
The Hong Kong General Union of Lift and Escalator Employees

# Proposed Chop Sample for Lift/Escalator Engineer/Worker

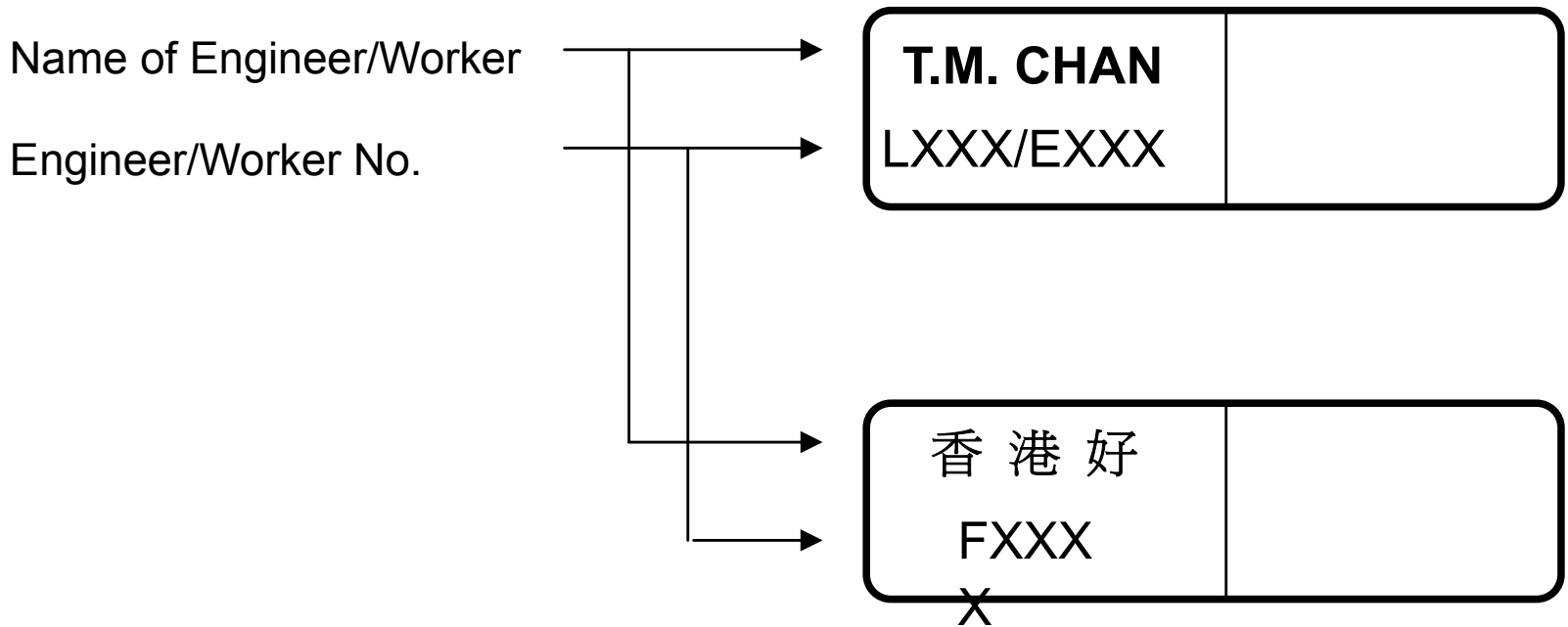

(1)		(2)			(3)	(4)		(5)	(6)		(7)	(8)	(9)
Contractor's Representative Arrived at Site 承建商代表抵達現場		Type of Work 工作類別			Lift or Escalator Number 升降機或自動梯編號	Passenger Released 放出被困者		Cause of Fault or Work Done &/or Parts Replaced 故障原因或完成之工作及/或更換之部份	Service Resumed 恢復操作		Engineer's or Worker's Chop & Signature 工程師或工人之印章及簽署	Remark(s) 備註	Owner's or Owner Agent's Name & Signature 物主或物主代理之姓名及簽署
Date 日期	Time 時間	Breakdown 壞機	Trapping 困人	Routine 例行	Date 日期	Time 時間	Date 日期		Time 時間				

SAMPLE