

CODE OF PRACTICE GU01

TESTING METHODS FOR APPROVAL OF
FLEXIBLE GAS TUBING FOR
LOW PRESSURE APPLICATIONS



(Issue 3, 2026)

Foreword

- 1.1 This document should be read in conjunction with the latest version of Code of Practice GU01 - Approval of Flexible Gas Tubings for Low Pressure Applications issued by the Gas Authority.
- 1.2 The Applicant shall supply the prescribed number of lengths of a model of Flexible Gas Tubing to a HOKLAS laboratory in Hong Kong with notification to the Gas Authority for carrying out a basic safety assessment test in accordance with the following test methods and any additional requirements as prescribed by the Gas Authority by reference to recognised type-specific product safety standard(s). A Basic Safety Assessment Certificate issued by the HOKLAS laboratory shall thus be obtained and submitted to the Gas Authority.

Appendix 1: Test Method GL-CG-4 "Testing of Flexible Rubber Tubing and Tubing Assembly for Use in LPG & town gas Low Pressure Installations" issued by the Government Laboratory, the Hong Kong Special Administrative Region.

Appendix 2: Test Method GL-CG-5 "Testing of Durable Flexible Rubber Tubing Assembly for Use in LPG & town gas Low Pressure Installations" issued by the Government Laboratory, the Hong Kong Special Administrative Region.

Test Method GL-CG-4

(Version No. 2, Implementation date: 11 November 2024)

“Testing of Flexible Rubber Tubing and Tubing Assembly for Use in LPG & Town Gas Low Pressure Installations”

issued by the Government Laboratory, the Hong Kong Special Administrative Region.

All testing procedures described in this method shall be carried out by competent laboratory workers. The safety precaution given in the method does not purport to address all of the safety concerns associated with the method’s use. It is the responsibility of the user of this method to follow appropriate safety and health measures applicable to chemical, physical and mechanical testing laboratories.

Enquiry on the current edition of the Test Method GL-CG-4 can be made to the following contact:

The Government of the Hong Kong Special Administrative Region
Government Laboratory,
Ho Man Tin Government Offices,
88 Chung Hau Street,
Kowloon,
Hong Kong.
Tel.: 2180 9155
Fax: 2180 9179

Testing of Flexible Rubber Tubing and Tubing Assembly for Use in LPG & Town Gas Low Pressure Installations

Safety Precaution: *The method involves pressurised equipment, flame tests, town gas and butane vapour. Use personal safety equipment, such as face shields, and carry out work involving flammable materials in a fumehood.*

1. Introduction

1.1. This method applies exclusively to tubing and tubing assemblies used in LPG and town gas installations not exceeding 0.05 bar (5000 Pa) operating pressure. For the purpose of this method, "tubing" is defined as a flexible pipe made of rubber without reinforcement; while "tubing assembly" is defined as a tubing with non-metallic braiding and end fittings.

1.2. This method applies to the following types and size of tubing (section 4.1) :

Gas Type	Town Gas	Town Gas	Town Gas and LPG	Town Gas and LPG
Nominal Bore Diameter (mm)	9.4	13.2	8.8	8.0
Bore Tolerance (mm)	± 0.4	± 0.5	± 0.4	± 0.4

1.3. For carrying out a complete set of experiments described in this method, the minimum sample size shall be 8 m long of tubing sample or 18 whole pieces of tubing assembly (each with a length of at least 0.75 m). Unless otherwise specified, all tests are carried out at ambient temperature.

1.4. Performance requirements :

Remark: *Unless otherwise specified, all tests on tubing assembly shall be conducted with the braiding and end fittings removed.*

1.4.1. Strength, adhesion and stretch (section 4.2.):

Part I (applicable to tubing)

When tested as described in section 4.2. Part I, the test pieces shall fit over the standard nozzle and the oversize nozzle, and shall remain attached to both nozzles throughout the period of test and shall show no signs of splitting, or excessive cracks and no leakage when tested at 0.7 bar (70000 Pa) air pressure under water for 5 minutes.

Part II (applicable to tubing assembly)

When tested as described in section 4.2. Part II, the test pieces shall show no cracks, flaws or leakage.

1.4.2. Resistance to pressure (section 4.3.):

When immersed in water for 5 minutes under an internal air pressure of 3.5 bar (350000 Pa), the increase in outer diameter shall not be more than 15% and there shall be no sign of leakage.

1.4.3. Resistance to kinking (section 4.4.):

When tested as described in section 4.4., the gas pressure shown on the manometer shall not drop by more than 0.01 bar (1000 Pa) during kinking.

1.4.4. Burning behaviour when exposed to a small flame (section 4.5.):

The test piece shall not burn to either of the outer marks within the test period of 45 seconds. The test piece then shall not leak when tested at a pressure of 0.05 bar (5000 Pa) for ten minutes.

1.4.5. Flexibility and resistance to n-pentane (section 4.6.):

After immersion in n-pentane for 72 hours, the pentane absorbed shall not exceed 15% w/w of the initial mass of the test piece and the amount of pentane-extractable matter shall not exceed 10% w/w of the initial mass of the test piece. After immersion and 72 hours further conditioning, the test piece shall make contact with at least 110° of the circumference of a former of radius 85 mm when a mass of 1.6 kg is attached to each end of the test piece. The test piece shall not show any sign of cracking.

1.4.6. Resistance to crushing (section 4.7.):

When tested as described in section 4.7.1., the test piece shall not show subsequent deformation or collapse after removal of a crushing force of 125

N, nor shall it leak when subjected to an internal pressure of 0.75 bar (75000 Pa). When tested as described in section 4.7.2., the gas flow rate shall not be less than 1.2 L/min.

1.4.7. Resistance to edible oil (section 4.8.):

The test piece shall be fitted at both ends with metal plugs of suitable size (as detailed in section 4.8.1.) and immersed in edible oil for 24 hours at 120 °C and further heated at 120 °C for 24 hours. The plugs shall remain attached during the period of test. Further, the test piece shall make contact with at least 80° of the circumference of a former of radius 85 mm when a mass of 1.6 kg is attached to each end of the test piece. The test piece shall not show any sign of cracking.

1.4.8. Resistance to bending (section 4.9.)

When tested as described in section 4.9., the deformation in the outside diameter shall not be greater than 10%.

1.4.9. Resistance to ozone (section 4.10.)

When tested as described in section 4.10., the test pieces shall show no cracks.

2. Reagents

2.1. Pressurised air supply

2.2. Butane gas, 98% minimum

2.3. n-Pentane, 98% minimum

2.4. Edible oil (peanut oil, food grade)

2.5. Wetting agent (such as household detergent)

2.6. Town gas

3. Apparatus

The following apparatus or their equivalents shall be used in the testing :

- 3.1. Pressurisation kit
- 3.2. Standard nozzles (Figure 1)
- 3.3. Oversize nozzles (Figure 2)
- 3.4. Crushing test assembly (Figure 5)
- 3.5. Bending test assembly (Figure 6 & 7)
- 3.6. Calibrated flow-meter and rotameter
- 3.7. Water manometer
- 3.8. Vernier calliper (Resolution: 0.01 mm)
- 3.9. Standard weight 2.9 ± 0.01 kg
- 3.10. Former of radius 85 mm
- 3.11. Two pieces of standard weight each with 1.6 ± 0.01 kg
- 3.12. Standard weight 7.46 ± 0.01 kg
- 3.13. Bunsen burner setup
- 3.14. Digital pressure meter
- 3.15. Ovens, $70 \pm 3^{\circ}\text{C}$, $120 \pm 5^{\circ}\text{C}$
- 3.16. Timer
- 3.17. Four pieces of standard weight with 22.5 ± 0.03 kg
- 3.18. Metal ruler
- 3.19. Magnifying lens, $\times 2$ magnification
- 3.20. Sample holders, see figure 8
- 3.21. Ozone chamber capable of generating ozone, monitoring and controlling the ozone concentration to 50 ± 5 parts per hundred million (pphm) at $40 \pm 2^{\circ}\text{C}$.

4. Procedures

4.1. Bore diameter:

Use a vernier calliper to measure the internal diameter of the test piece at one end. Take four readings at approximately equally spaced intervals along the inner circumference of the bore. If the bore is distorted, use another portion of the test piece. Repeat the measurement with another portion of the test piece. Average the eight readings.

4.2. Strength, adhesion and stretch test :

Either Part I or Part II of the test shall be carried out depending on which one is applicable.

Part I (applicable to tubing)

4.2.1. Prepare at least 4 test pieces from the sample tubing, each 150 mm long, with smooth ends. Check cut ends to ensure absence of cracks. If cracks are present prepare another test piece. Clean the test pieces to remove any lubricant present.

4.2.2. Force each test piece over a standard nozzle at one end and an oversize nozzle at the other. Allow the specimens to equilibrate for about 2 hours before continuing further. Use metal nozzles of sizes appropriate for the tubing under test. (see Figures 1 and 2).

	Nominal bore diameter (mm)	9.4	13.2	8.8	8.0
Standard nozzle	Outer nozzle diameter (mm)	11.5	16.5	11.5	10.3
Oversize nozzle	Outer nozzle diameter (mm)	18.6	21.3	17.5	15.9

4.2.3. Suspend the test pieces vertically and attach a total mass of 4.5 kg to the lower (oversize) nozzle of each test piece (ensure that both the test piece and the suspended weight are hanging in the same vertical axis) and leave the test piece for half an hour. Reject any test piece that slips off either nozzle during this period.

- 4.2.4. Further heat the unrejected assemblies in an oven at $70 \pm 3^{\circ}\text{C}$ for 7 days (168 hours). Examine for signs of splitting or excessive cracks.
- 4.2.5. Cool to room temperature and examine each test piece for leakage at 0.7 bar (70000 Pa) internal pressure under water for 5 minutes. There shall not be any sign of leakage.

Part II (applicable to tubing assembly)

- 4.2.6. Minimum four whole pieces of tubing assembly with intact braiding and end fittings shall be tested.
- 4.2.7. Suspend each test piece vertically with a mass of 22.5 kg attached to its lower end and leave the assembly to stand for 30 minutes. Examine the test pieces and reject those which show signs of fracture or cracks.
- 4.2.8. Remove the braiding of the test pieces which were not rejected, test for leakage by immersing the de-braided test pieces in water for 5 minutes with an internal pressure of 0.7 bar (70000 Pa). After the immersion, reject those test pieces which show signs of leakage.
- 4.2.9. Place the test pieces which were not rejected in 4.2.8 in an ageing oven for 7 days (168 hours) at $70 \pm 3^{\circ}\text{C}$ and after cooling to room temperature, immerse them in water for 5 minutes with an internal air pressure of 0.7 bar (70000 Pa). Re-examine the test pieces for leakage.

4.3. Resistance to pressure test:

- 4.3.1. Measure the outer diameter of a test piece of about 150 mm long using a vernier calliper. Take four readings approximately equally spaced around the outer diameter at a point near the centre of the length of the test piece and average the four readings.
- 4.3.2. Test the test piece at an internal pressure of 3.5 bar (350000 Pa) for 5 minutes under water. Check for leakage.
- 4.3.3. Remove the test piece from water and measure the average outer diameter of the test piece as in 4.3.1 while still subjecting it to 3.5 bar

(350000 Pa) air pressure. (If there are obvious areas of swelling, measure the average diameter at those points.) The increase in diameter shall not be more than 15%.

4.4. Test for resistance to kinking:

4.4.1. Prepare a test piece with approx. 80 cm in length (for tubing assembly, use the whole length of the assembly with braiding as the test piece). Connect one end of the test piece to a supply of butane gas and the other end to a water manometer and a flow-meter. Make sure that about 60 cm of the test piece lies horizontally on the bench.

4.4.2. Adjust the flow regulator so as to achieve a flow rate of 3.75 L/min and a pressure of 0.028 bar (2800 Pa).

4.4.3. Take in the fingers two points on the test piece spaced according to the table below and bring them together so that the test piece takes the form of a loop. (Figure 3)

Nominal bore diameter (mm)	9.4	13.2	8.8	8.0
Spacing (mm)	330	465	310	280

In the case of tubing assembly, use the spacing corresponding to a nominal bore that is closest to the nominal bore of the assembly tubing.

4.4.4. Hold the loop for 30 seconds and record the pressure drop shown on the manometer during this period. The pressure drop shall not be more than 0.01 bar (1000 Pa).

4.5. Test for burning behaviour:

4.5.1. Support horizontally a test piece with approx. 15 cm in length, using clamp and stand (Figure 4). Make 3 marks with a felt pen, one at the mid-point and two marks of 5 cm from either side of the mid-point.

- 4.5.2. Direct a well aerated Bunsen flame (approximately 1800 kJ/h and about 25 mm in diameter) horizontally to the mid-point mark for 5 seconds and remove it for one second.
- 4.5.3. Repeat the application of the flame as above until the material catches fire and continues to burn or until a total test period of 45 seconds has elapsed.
- 4.5.4. If the material catches fire and continues to burn without further application of flame, note whether the flame reaches either of the outer marks within 45 seconds of the commencement of the test.
- 4.5.5. Further, test the burnt test piece for leakage by applying an internal pressure of 0.05 bar (5000 Pa) for ten minutes under water. The test piece shall not show any sign of leakage.
- 4.6. Test for resistance to n-pentane and test for flexibility:
 - 4.6.1. Weigh (W_0) a test piece of about 40 cm in length and immerse it in n-pentane for 72 hours. The volume of the n-pentane shall be at least 20 times the volume of the test piece and is sufficient to cover the whole test piece.
 - 4.6.2. Remove the test piece from n-pentane, condition it in ambient air for 5 minutes and reweigh (W_1).
 - 4.6.3. Further condition the test piece in ambient air for 72 hours and reweigh (W_2).
 - 4.6.4. Calculate the % w/w n-pentane absorbed and the % w/w extractable matter. (see section 5.4.).

- 4.6.5. Further, bend the test piece round a former of radius 85 mm and attach a mass of 1.6 kg to each end of the test piece. Contact shall be made with at least 110° of the circumference of the former. Examine the test piece for any sign of cracking.
- 4.7. Test for resistance to crushing:
- 4.7.1. Take a test piece of minimum length of 100 mm and place it under the foot of the 'Crushing Test Assembly'. (Figure 5). Attach a load of 7.46 kg to the end of the arm of the assembly for 30 seconds (This force is equivalent to 125 N over a length of 25 mm of the test piece). Remove the force and check if there is any deformation or collapse. Further, test the test piece for leakage when subjected to an internal pressure of 0.75 bar (75000 Pa). The test piece shall not show any sign of leakage.
- 4.7.2. Connect one end of the test piece to a supply of butane gas maintained at a constant pressure of 0.028 bar (2800 Pa). Connect the other end to a variable flow control and adjust the flow to 4.67 L/min. Place the test piece under the foot of the 'Crushing Test Assembly' and apply force by attaching the 7.46 kg weight to the end of the arm of the assembly. After 30 seconds note the butane gas flow rate. It shall not be less than 1.2 L/min.
- 4.8. Test for resistance to edible oil:
- 4.8.1. Take a test piece of about 40 cm in length (Check cut ends to ensure absence of cracks. If cracks are present prepare another test piece) and close off the ends with metal plugs of dimensions identical to the standard nozzles of size appropriate for the sample under test (for test piece from tubing assembly, use the 11.5 mm nozzles if the nominal bore of the test piece \leq 10 mm or use the 16.5 mm nozzles if the nominal bore $>$ 10 mm). Allow the test piece to equilibrate in ambient conditions for about 2 hours before continuing further.

- 4.8.2. Immerse the test piece in edible oil at 120 ± 5 °C for 24 hours. The volume of oil shall be at least 10 times the volume of the test piece and sufficient to cover the whole test piece. The end plugs shall not come off during this period.
- 4.8.3. Remove the test piece from the edible oil, drain off excess oil and place the test piece in an oven at 120 ± 5 °C for 24 hours. Remove the test piece from the oven, allow to cool to room temperature and examine the test piece for cracks particularly at the ends where the plugs are inserted.
- 4.8.4. Bend the test piece round a former of radius 85 mm and attach a mass of 1.6 kg to each end of the test piece. Contact shall be made with at least 80° of the circumference of the former. Examine the test piece for any sign of cracking.

4.9. Bending test:

- 4.9.1. Measure the outer diameter D of a test piece using a vernier calliper. Take four readings approximately equally spaced around the outer diameter at a point near the centre of the length of the test piece and average the four readings.
- 4.9.2. Draw two parallel and diametrically opposed lines along the length of the test piece. If the test piece has natural curvature, one of the lines shall be on the outside of the curve. On each of these lines, mark a distance of $18D$, so that the marked distances are exactly opposed.
- 4.9.3. Separate the guides A and B (Figure 6) to a distance slightly less than $18D$. Place the test piece between the guides so that the ends of the marked distances are parallel to the ends of the guides and remain in this position while the guides are closed to a distance of $12D$. Check that the test piece on each side is supported to a length of not less than D .
- 4.9.4. Measure the test piece outside dimension, T , at any point in the curved portion of the test piece. The value for T/D shall not be less than 0.90 (Figure 7).

4.10. Test for resistance to ozone:

4.10.1. Carry out the test on two test pieces of the sample.

4.10.2. Mount each test piece on an appropriate sample holder, as shown in figure 8. The radius r_b shall be equal to six times the internal diameter of the test piece.

4.10.3. Seal the ends of the test pieces to prevent absorption of ozone by the inner lining.

4.10.4. Condition the test pieces under ambient conditions in darkness for 48 hours.

4.10.5. Expose the test pieces in an ozone chamber to an ozone concentration of 50 ± 5 parts per hundred million (pphm) by volume at 40 ± 2 °C for 72 hours.

4.10.6. Examine the test pieces after the exposure, whilst still in the extended condition, under $\times 2$ magnification, ignoring the area adjacent to the fixing points. If cracks are discovered, record their nature.

5. Calculation / Result interpretation

- 5.1. Report the average bore diameter to 0.1mm.
- 5.2. Report other specifications as passed or failed.
- 5.3. Indicate on the report if a test piece failed any of the specifications but test pieces taken from further samples of the same batch or consignment passed.
- 5.4. Calculate the % w/w n-pentane absorbed and % w/w extractable matter as follows:-

$$(a) \text{ \% w/w n-pentane absorbed} = \frac{W_1 - W_2}{W_0} \times 100$$

$$(b) \text{ \% w/w extractable matter} = \frac{W_0 - W_2}{W_0} \times 100$$

where W_0 = initial mass of test piece, g;
 W_1 = mass of test piece after immersion and 5 minutes conditioning, g;
 W_2 = mass of test piece after 72 hours further conditioning, g.

6. Quality Control Requirements

- 6.1. All equipment used in this method shall be calibrated in conformance with the requirements of ISO/IEC 17025:2017/latest version to ensure traceability to the International System of Units (SI).

7. References

- 7.1. *Specification for Flexible rubber tubing, rubber hose and rubber hose assemblies for use in LPG vapour phase and LPG/air installations, BS 3212:1991, British Standards Institution.*
- 7.2. *Rubber or plastics hoses and tubing – Bending tests, ISO 1746:1998(E), International Organization for Standardization.*
- 7.3. *Rubber and plastics hoses – Assessment of ozone resistance under static conditions, BS EN 27326:1993, ISO 7326:1991, British Standards Institution.*
- 7.4. *General requirements for the competence of testing and calibration laboratories, ISO/IEC 17025:2017, International Organization for Standardization.*

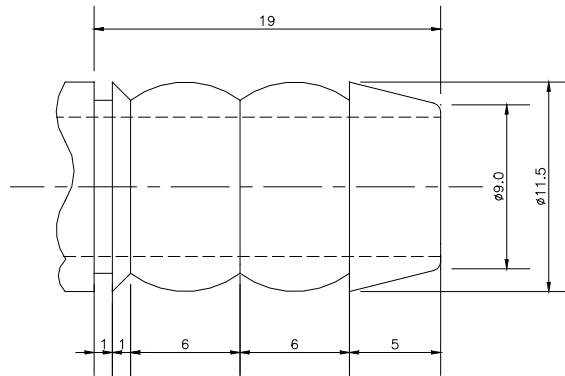

(FOR 8.8/9.4 mm)

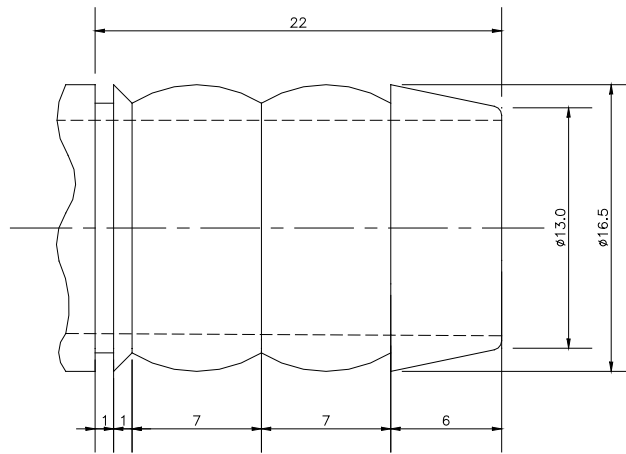

(FOR 13.2 mm)

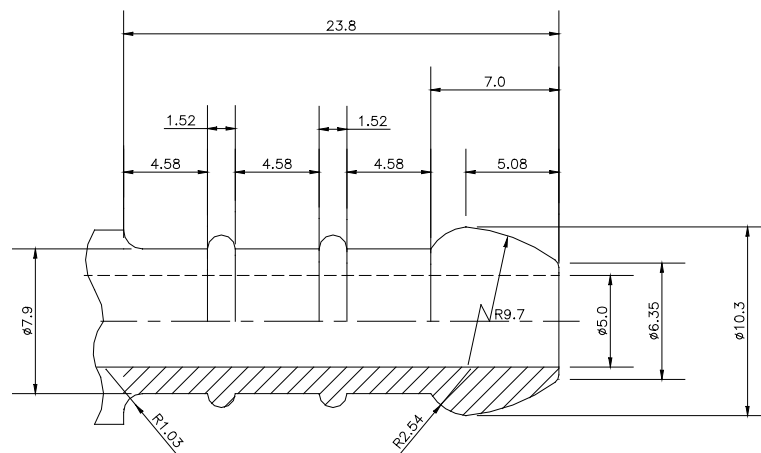

(FOR 8.0 mm)

All dimensions are in millimeters.

Tolerance on diameter is 0.2mm and length is 0.5mm.

Figure 1: Standard metal nozzles

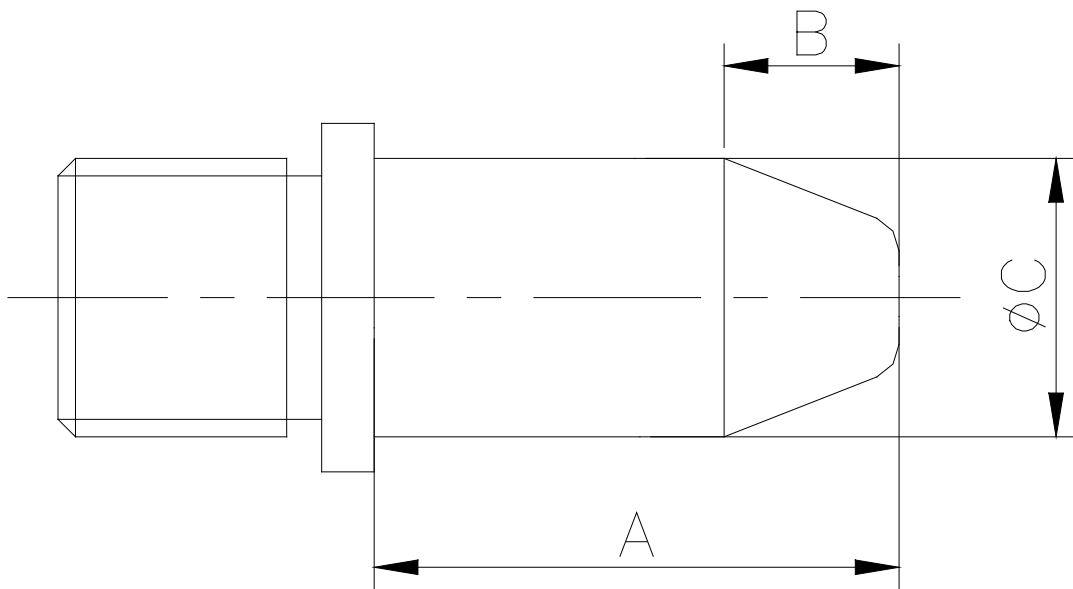

	Rubber Tubing Nominal Bore			
	8.0 (mm)	8.8 (mm)	9.4 (mm)	13.2 (mm)
A	30	30	30	40
B	10	10	10	10
dia C	15.9	17.5	18.6	21.3

All dimensions are in millimeters.

Tolerance on diameter is 0.2mm and length is 0.5mm.

Figure 2: Oversize metal nozzles

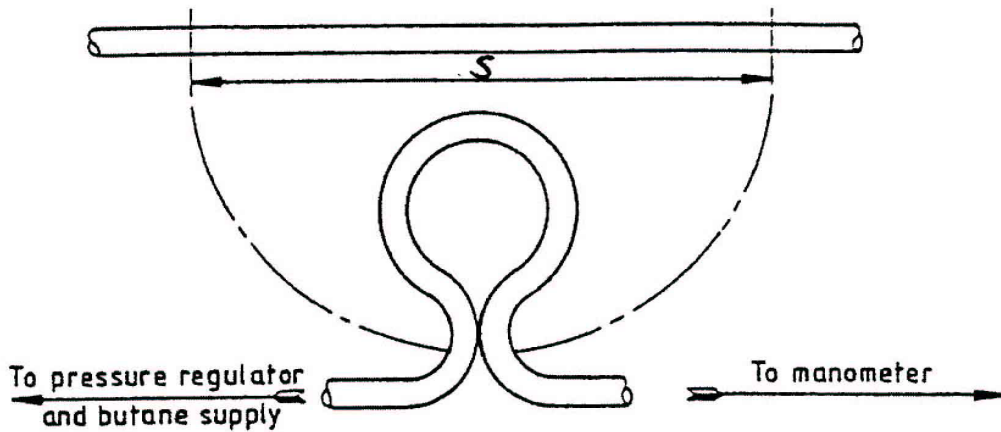

NOTE. Not to scale.

Nominal Bore Diameter (mm)	8.0	8.8	9.4	13.2
Spacing (S) (mm)	280	310	330	465

Figure 3: Diagram for the Test for resistance to kinking

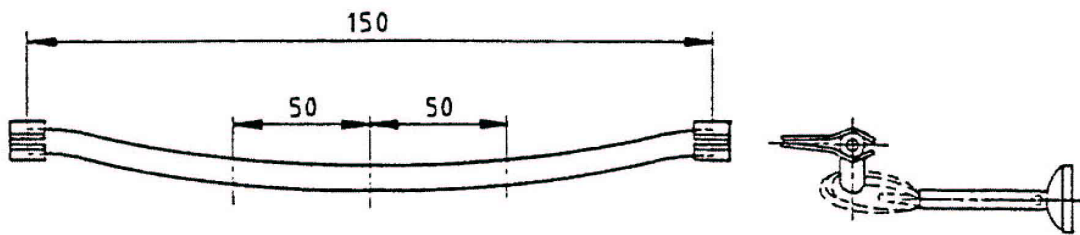

Dimensions are in millimetres.

Figure 4 : Diagram for the Test for burning behaviour

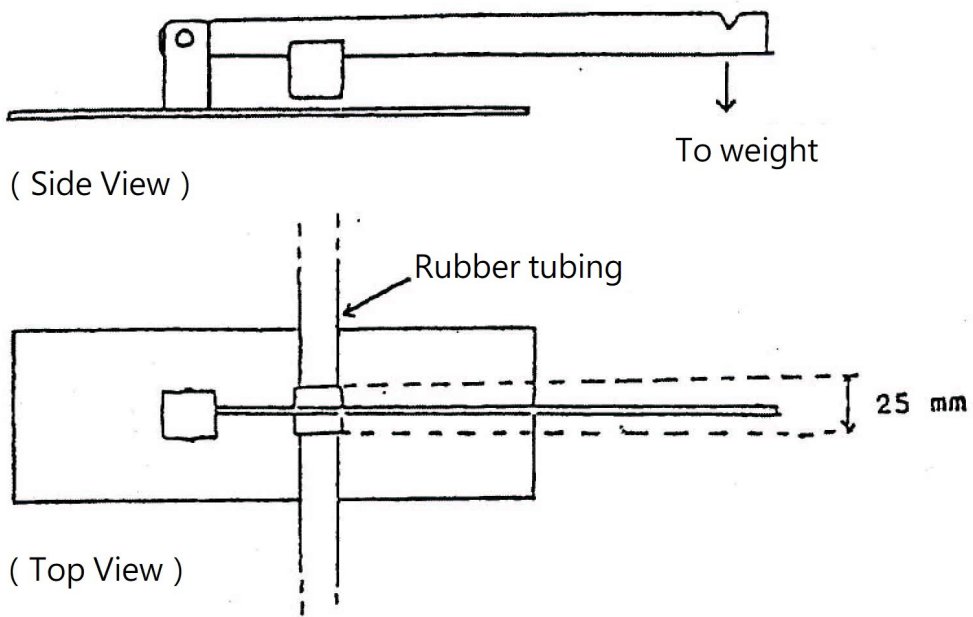

No to scale

Figure 5 : Diagram for the Test for resistance to crushing

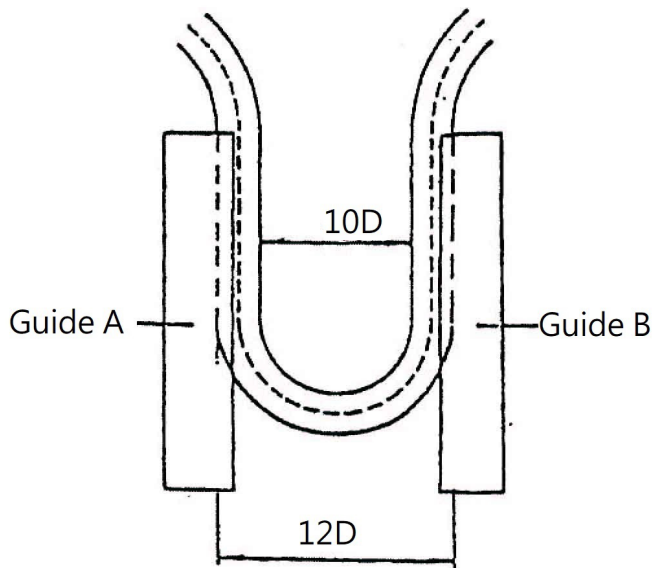

Figure 6

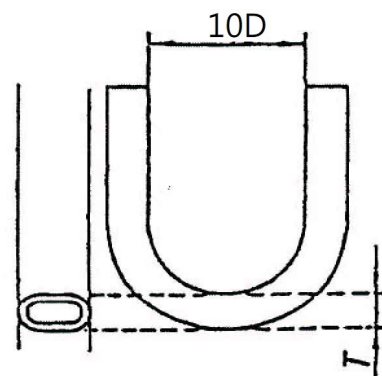
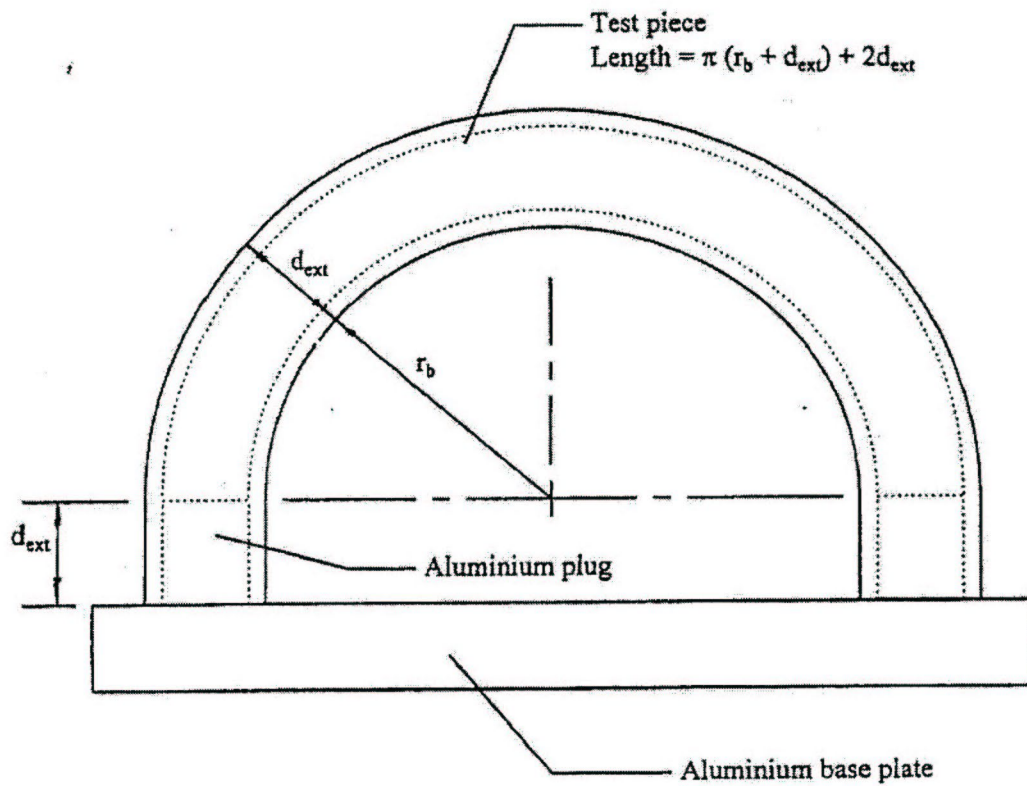

Figure 7

Figure 6 and Figure 7 : Diagram for bending test



The length of the test piece shall be calculated by the formula

$$L = \pi (r_b + d_{ext}) + 2d_{ext}$$

where

L is the length of the test piece in mm;

r_b is the bend radius of the test piece in mm, which shall be equal to six times its outside diameter;

d_{ext} is the outside diameter of the test piece in mm.

Figure 8: Arrangement for mounting test piece on a sample holder for determination of ozone resistance

Test Method GL-CG-5

(Version No. 2, Implementation date: 11 November 2024)

**“Testing of Durable Flexible Rubber Tubing Assembly for Use in
LPG & Town Gas Low Pressure Installations”**

**issued by the Government Laboratory, the Hong Kong Special
Administrative Region.**

All testing procedures described in this method shall be carried out by competent laboratory workers. The safety precaution given in the method does not purport to address all of the safety concerns associated with the method’s use. It is the responsibility of the user of this method to follow appropriate safety and health measures applicable to chemical, physical and mechanical testing laboratories.

Enquiry on the current edition of the Test Method GL-CG-5 can be made to the following contact:

The Government of the Hong Kong Special Administrative Region
Government Laboratory,
Ho Man Tin Government Offices,
88 Chung Hau Street,
Kowloon,
Hong Kong.
Tel.: 2180 9155
Fax: 2180 9179

Testing of Durable Flexible Rubber Tubing Assembly for Use in LPG & Town Gas Low Pressure Installations

Safety Precaution: *The method involves pressurised and/or mechanical equipments, flame tests, town gas and butane gas. Use personal safety equipment, such as face shields, protective gloves, safety shoes and carry out work involving flammable materials in a fumehood.*

1. Introduction

- 1.1. This method applies to flexible rubber tubing assemblies intended for prolonged used in LPG and town gas installations not exceeding an operating pressure of 0.05 bar (5000 Pa). For the purpose of this method, "tubing assembly" is defined as tubing with metallic braiding and end fittings.
- 1.2. This method applies to the following tubing :

Fuel Type	Town Gas	Town Gas	Town Gas and LPG	Town Gas and LPG
Nominal Bore Diameter (mm)	9.4	13.2	8.8	8.0
Bore Tolerance (mm)	± 0.4	± 0.5	± 0.4	± 0.4

- 1.3. For carrying out a complete set of experiments described in this method, the minimum sample quantity shall be 20 pieces of tubing assembly (each with a length of at least 0.75 m). Unless otherwise specified, all tests are carried out in ambient laboratory environment.
- 1.4. Tubing assembly should pass all performance test including resistance to pressure, resistance to kinking, burning behaviour, flexibility and resistance to n-pentane, resistance to crushing, resistance to edible oil, resistance to bending, resistance to cutting, proof pressure test, resistance to stretch, resistance to ozone, tensile test and resistance to heat.

2. Reagents

- 2.1. Compressed air
- 2.2. Butane gas, 98% minimum in purity
- 2.3. n-Pentane, 98% minimum in purity
- 2.4. Edible oil (food grade)
- 2.5. Wetting agent (such as household detergent)
- 2.6. Town gas

3. Apparatus

The following apparatus or their equivalents shall be used in the testing :

- 3.1. Vernier calliper (Resolution: 0.01mm)
- 3.2. Pressurisation kit
- 3.3. Flow-meter and rotameter
- 3.4. Water manometer
- 3.5. Steel ruler
- 3.6. Standard nozzles (Figure 1)
- 3.7. Timer
- 3.8. Bunsen burner setup
- 3.9. Top pan balance, readable to 0.01 g
- 3.10. Former, 85 mm in radius
- 3.11. Two pieces of standard weight each with 1.6 ± 0.01 kg
- 3.12. Crushing test assembly (Figure 4)
- 3.13. Metal plugs
- 3.14. Bending test assembly (Figure 5 & 6)
- 3.15. Cutting test assembly (Figure 7)
- 3.16. Ovens, $120 \pm 5^{\circ}\text{C}$, $100 \pm 3^{\circ}\text{C}$
- 3.17. Ozone chamber capable of generating ozone at concentration of 50 ± 5 parts per hundred million (pphm) and at temperature of $40 \pm 2^{\circ}\text{C}$
- 3.18. Magnifying lens, $\times 2$ magnification

3.19. Sample holders for resistance to ozone test (Figure 8)

3.20. Tensile tester

4. Procedures

Remark: *Unless otherwise specified, all tests on tubing assembly shall be conducted with the braiding and end fittings removed.*

4.1. Bore diameter:

Measure the internal diameter of the test piece at one end with a vernier calliper. Take four readings at approximately equally spaced intervals along the inner circumference of the bore. If the bore is distorted, use another portion of the test piece. Repeat the measurement with another portion of the test piece. Average the eight readings.

4.2. Resistance to pressure test:

4.2.1. Test a braided test piece with end fittings at an internal pressure over 8 bar (800000 Pa) for at least 1 minute.

4.2.2. Check for leakage. There shall be no sign of leakage or cracking or deformation.

4.3. Test for resistance to kinking:

4.3.1. Connect one end of a test piece to a supply of butane gas, and connect the other end to a water manometer and a flow-meter. Make sure that about 60 cm of the test piece lies horizontally on the bench.

4.3.2. Adjust the flow regulator so as to achieve a butane gas flow rate of 3.75 L/min and a pressure of 0.028 bar (2800 Pa).

4.3.3. Take in the fingers two points on the test piece spaced according to the table below and bring them together so that the test piece takes the form of a loop. (Figure 2)

Nominal bore diameter (mm)	8.0	8.8	9.4	13.2
Spacing, S (mm)	280	310	330	465

- 4.3.4. Hold the loop for 30 seconds and record the pressure reading shown on the manometer at this time. The pressure drop shall not be more than 0.01 bar (1000 Pa).
- 4.4. Test for burning behavior:
 - 4.4.1. Support horizontally a test piece with approx. 15 cm in length, using clamp and stand (Figure 3). Make 3 marks with a felt pen, one at the mid-point and two at 5 cm away from either side of the mid-point.
 - 4.4.2. Direct a well aerated bunsen flame (approximately 1800 kJ/h and about 25 mm in diameter) horizontally to the mid-point mark for 5 seconds and remove it for one second.
 - 4.4.3. Repeat the application of the flame as above until the material catches fire and continues to burn or until a total test period of 45 seconds has elapsed.
 - 4.4.4. If the material catches fire and continues to burn without further application of flame, note whether the flame reaches either of the outer marks within 45 seconds of the commencement of the test. The test piece shall not burn to either of the outer marks within the test period of 45 seconds.
 - 4.4.5. Examine the burnt test piece for leakage by applying an internal pressure of 0.05 bar (5000 Pa) for ten minutes under water. The test piece shall not show any sign of leakage.
- 4.5. Test for resistance to n-pentane and test for flexibility:
 - 4.5.1. Weigh (W_0) a test piece of about 40 cm in length and immerse it in n-pentane for 72 hours. The volume of the n-pentane shall be at least 20 times the volume of the test piece and is sufficient to cover the whole test piece.
 - 4.5.2. Remove the test piece from n-pentane, condition it in ambient air for 5 minutes and reweigh (W_1).
 - 4.5.3. Further condition the test piece in ambient air for 72 hours and reweigh (W_2).

- 4.5.4. Calculate the % w/w n-pentane absorbed and the % w/w extractable matter. (see section 5.4.). The pentane absorbed shall not exceed 15% w/w of the initial mass of the test piece and the amount of pentane-extractable matter shall not exceed 10% w/w of the initial mass of the test piece.
- 4.5.5. Further, bend the test piece round a former of radius 85 mm and attach a mass of 1.6 kg to each end of the test piece. Contact shall be made with at least 110° of the circumference of the former. Examine the test piece for any sign of cracking. The test piece shall show no sign of cracking.
- 4.6. Test for resistance to crushing:
- 4.6.1. Fix a braided test piece with end fittings onto the 'Crushing Test Assembly' (Figure 4) under a stream of air at a pressure of 0.028 bar (2800 Pa) and a flow rate of 0.5 m³/hour. Attach a load to the end of the arm of the assembly for 1 min., so that a force equivalent to over 600 N (in the range of 600 – 630 N) is applied over 10 cm at the centre of the test piece at right angle.
- 4.6.2. The drop of flow rate shall not exceed 50 %.
- 4.7. Test for resistance to edible oil:
- 4.7.1. Take a test piece of about 40 cm in length (examine cut ends to ensure absence of cracks. If cracks are present prepare another test piece) and close off the ends with metal plugs of dimensions identical to the standard nozzles of size appropriate for the sample under test (use the 11.5 mm nozzles if the nominal bore of the test piece ≤ 10 mm or use the 16.5 nozzles if the nominal bore > 10 mm). Allow the test piece to equilibrate in ambient conditions for about 2 hours before continuing further.
- 4.7.2. Immerse the test piece in edible oil at 120 ± 5 °C for 24 hours. The volume of oil shall be at least 10 times the volume of the test piece and sufficient to cover the whole test piece. The end plugs shall not come off during this period.
- 4.7.3. Remove the test piece from the edible oil, drain off excess oil and place the test piece in an oven at 120 ± 5 °C for 24 hours. Remove the test piece from the oven; allow cooling to room temperature and examining the test piece for cracks particularly at the ends where the plugs are inserted.

- 4.7.4. Bend the test piece round a former of radius 85 mm and attach a mass of 1.6 kg to each end of the test piece. Contact shall be made with at least 80° of the circumference of the former. Examine the test piece for any sign of cracking. The test piece shall show no sign of cracking.
- 4.8. Bending test:
- 4.8.1. Measure the outer diameter D of a test piece using a vernier calliper. Take four readings approximately equally spaced around the outer diameter at a point near the centre of the length of the test piece and average the four readings.
- 4.8.2. Draw two parallel and diametrically opposed lines along the length of the test piece. If the test piece has natural curvature, one of the lines shall be on the outside of the curve. On each of these lines, mark a distance of $18D$, so that the marked distances are exactly opposed.
- 4.8.3. Separate the guides A and B (Figure 5) to a distance slightly less than $18D$. Place the test piece between the guides so that the ends of the marked distances are parallel to the ends of the guides and remain in this position while the guides are closed to a distance of $12D$. Check that the test piece on each side is supported to a length of not less than D .
- 4.8.4. Measure the test piece outside dimension, T , at any point in the curved portion of the test piece. The value for T/D shall not be less than 0.90 (Figure 6) (i.e. the deformation in the outside diameter shall not be greater than 10%).
- 4.9. Test for resistance to cutting:
- 4.9.1. Place a braided test piece with end fittings under a blade at a position of 100 mm away from the fulcrum of the 'Cutting Test Assembly' (Figure 7). Attach a load at a position of 500 mm from the fulcrum, so that a load equivalent to over 6 kg (in the range of 6.0 – 6.3 kg) is applied at the same position. Check for signs of cutting off.
- 4.9.2. Remove the test piece from the assembly, and test in accordance with section 4.10.
- 4.9.3. The test pieces shall not be cut off and there shall be no sign of leakage when tested as described in section 4.10.

4.10. Proof pressure test:

4.10.1. Test a braided test piece with end fittings at an internal air pressure of 0.35 bar (35000 Pa) for at least 1 min. Check for sign of leakage and pressure drop. There shall be no sign of leakage and pressure drop.

4.11. Test for resistance to stretch:

4.11.1. Fix a braided test piece with end fittings vertically from one end and apply slowly to another end, a force of over 600 N (in the range of 600 – 630 N) for 10 min. Check for signs of flaw. There shall be no flaws.

4.12. Test for resistance to ozone:

4.12.1. Carry out the test on two test pieces of the sample.

4.12.2. Mount each test piece on an appropriate sample holder, as shown in figure 8. The radius r_b shall be equal to six times the internal diameter of the test piece.

4.12.3. Seal the ends of the test pieces to prevent absorption of ozone by the inner lining.

4.12.4. Condition the test pieces under ambient conditions in darkness for 48 hours.

4.12.5. Expose the test pieces in an ozone chamber to an ozone concentration of 50 ± 5 ppm by volume at 40 ± 2 °C for 120 hours.

4.12.6. Examine the test pieces after the exposure, whilst still in the extended condition, under $\times 2$ magnification, ignoring the area adjacent to the fixing points.

4.12.7. The test pieces shall show no signs of cracking. If cracks are discovered, record their nature, including their shape, size, etc.

4.13. Tensile test:

4.13.1. Cut out three dumb-bell test pieces using a cutting die into the required dimensions as shown in Figure 9.

4.13.2. Make two gauge marks on the narrow part of the test piece and at equidistant from the center with width not greater than 1.0 mm. The

distance between the two gauge marks shall be as far as possible without exceeding 20 mm.

- 4.13.3. Fix the test piece on the tensile test machine so that tension is spread uniformly over the cross section and leaving a minimum distance of 55 mm between two grips.
 - 4.13.4. Apply tensile force by operating the tensile test machine at a rate of 500 ± 50 mm/min until the test piece breaks. Record the % elongation at break. The % elongation at break can also be calculated from the initial length between gauge marks and the length between gauge marks at break (see section 5.5.).
 - 4.13.5. Repeat 4.13.2 to 4.13.4 with two more test pieces.
 - 4.13.6. Calculate the average % elongation at break (see section 5.5.). The elongation at break of unaged test pieces shall not be less than 175 %.
- 4.14. Test for resistance to heat:
- 4.14.1. Place 1 unbraided test piece with end fitting as received and 3 other test pieces each with a minimum length of 100 mm in an oven for 14 days (334 - 336 hours) at $100 \pm 1^\circ\text{C}$ and then in room temperature for 4 days (94 - 96 hours).
 - 4.14.2. Fix one end of the unbraided test pieces with end fitting obtained in 4.14.1., and apply from another end, a twisting force of 90° clockwise and anticlockwise. Check for leakage at a pressure of 0.3 bar (30000 Pa) for at least 1 min. The test pieces shall show no signs of cracking or leakage.
 - 4.14.3. For the other three test pieces obtained in 4.14.1., cut out from each of them a dumb-bell portion using a cutting die from the axis of the troncon parallel to the sharp part of the punch in contact with the surface exposed to air at the time of ageing.
 - 4.14.4. Determine the % elongation at break of the cut-out portions as described in 4.13.2 to 4.13.4. Calculate the average % elongation at break (see section 5.5).
 - 4.14.5. Calculate the average relative percent degradation (see section 5.5.), the average relative percent degradation shall not exceed 50 %.

5. Calculation / Result interpretation

- 5.1. Report the average bore diameter to 0.1 mm.
- 5.2. Report other specifications as "passed" or "failed".
- 5.3. Indicate on the report if a test piece failed any of the specifications but test pieces taken from further samples of the same batch or consignment passed.
- 5.4. Calculate the % w/w n-pentane absorbed and % w/w extractable matter as follows:-

$$5.4.1. \quad \% \text{ w/w n - pentane absorbed} = \frac{W_1 - W_2}{W_0} \times 100$$

$$5.4.2. \quad \% \text{ w/w extractable matter} = \frac{W_0 - W_2}{W_0} \times 100$$

where W_0 = initial mass of test piece, g;
 W_1 = mass of test piece after immersion and 5 minutes conditioning, g;
 W_2 = mass of test piece after 72 hours further conditioning, g.

- 5.5. Calculate the % elongation at break and % degradation as follows:-

$$5.5.1. \quad \% \text{ Elongation at break, } EB_x = \frac{L - L_0}{L_0} \times 100$$

$$5.5.2. \quad \text{Average \% elongation at break, } \overline{EB}_x = \frac{\sum EB_{xi}}{n}$$

$$5.5.3. \quad \text{Average relative \% degradation, } D = \frac{\overline{EB}_0 - \overline{EB}_{100}}{\overline{EB}_0} \times 100$$

where L_0 = initial length between the gauge marks, mm;
 L = length between the gauge marks at break, mm;
 EB_x = % elongation at break before or after oven ageing;
 \overline{EB}_x = average % elongation at break before or after oven ageing;
 \overline{EB}_0 = average % elongation at break before oven ageing;
 \overline{EB}_{100} = average % elongation at break after oven ageing at 100°C.

6. Quality Control Requirements

- 6.1. All equipment used in this method shall be calibrated in conformance with the requirements of ISO/IEC 17025:2017/latest version to ensure traceability to the International System of Units (SI).

7. References

- 7.1. *Specification for Flexible rubber tubing, rubber hose and rubber hose assemblies for use in LPG vapour phase and LPG/air installations, BS 3212:1991, British Standards Institution.*
- 7.2. *Rubber or plastics hoses and tubing — Bending tests, ISO 1746:1998(E), International Organization for Standardization.*
- 7.3. *Rubber and plastics hoses — Assessment of ozone resistance under static conditions, BS EN 27326:1993, ISO 7326:1991, British Standards Institution.*
- 7.4. 液化石油ガス燃焼器接続用継手付ホース検査規程, LIA-440, 財団法人, 日本エルピーガス機器検査協会.
- 7.5. 液化石油ガス高性能供給機器検査規程, LIA-700, 財団法人, 日本エルピーガス機器検査協会.
- 7.6. *Household economy – (Reinforced) flexible rubber tubing for the external connection of domestic appliances using gaseous fuels by networks, NF D 36-103:2001, Norme française.*
- 7.7. *General requirements for the competence of testing and calibration laboratories, ISO/IEC 17025:2017, International Organization for Standardization.*

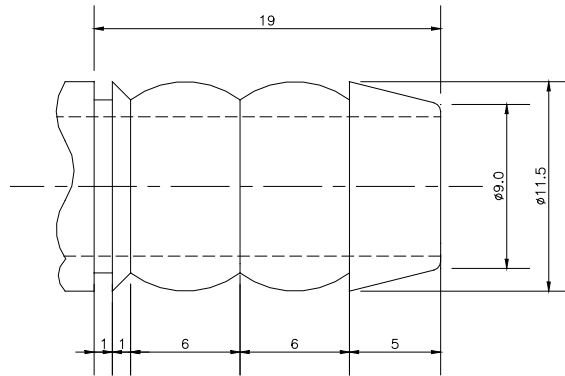

(FOR 8.8/9.4 mm)

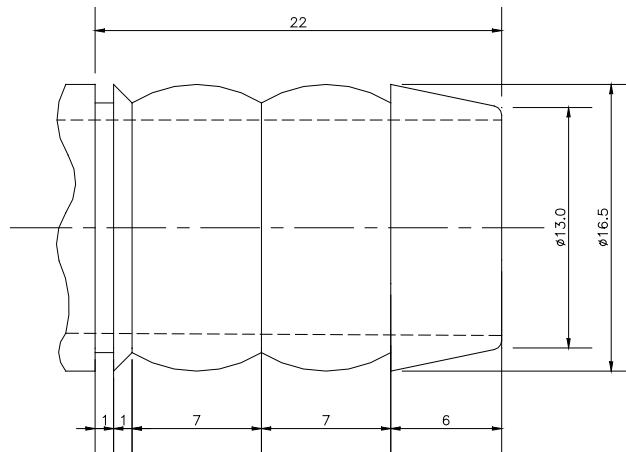

(FOR 13.2 mm)

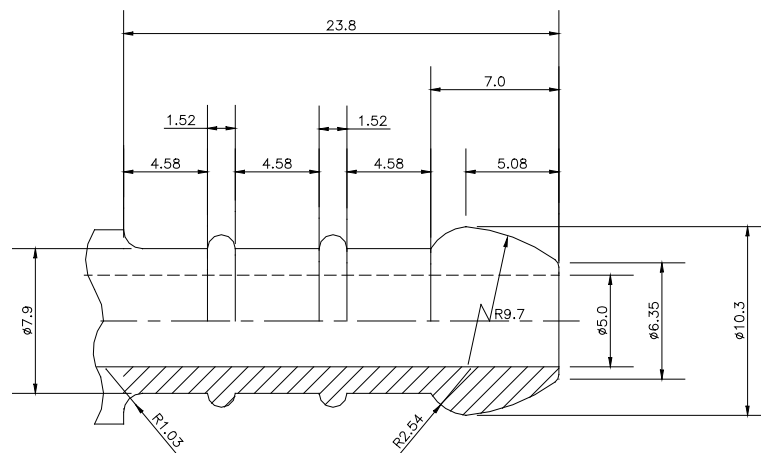

(FOR 8.0 mm)

All dimensions are in millimeters.

Tolerance on diameter is 0.2mm and length is 0.5mm.

Figure 1: Standard metal nozzles

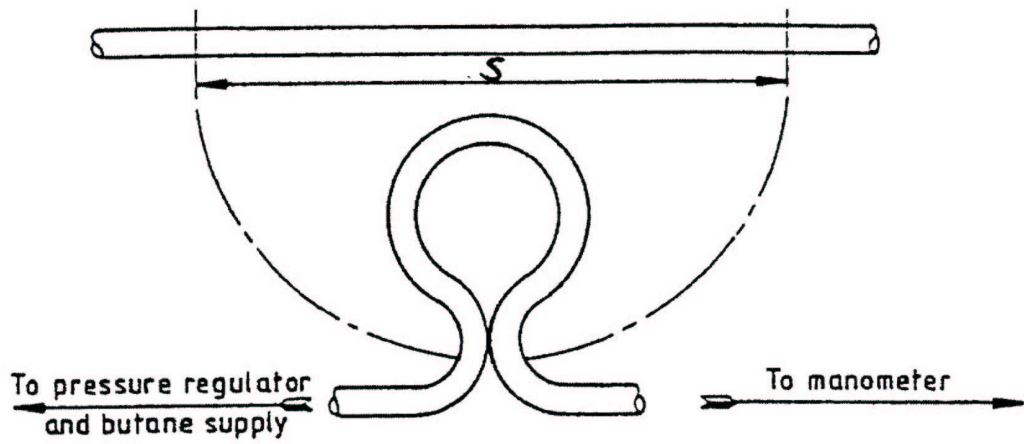

NOTE. Not to scale.

Nominal bore diameter (mm)	8.0	8.8	9.4	13.2
Spacing S (mm)	280	310	330	465

Figure 2: Resistance to kinking

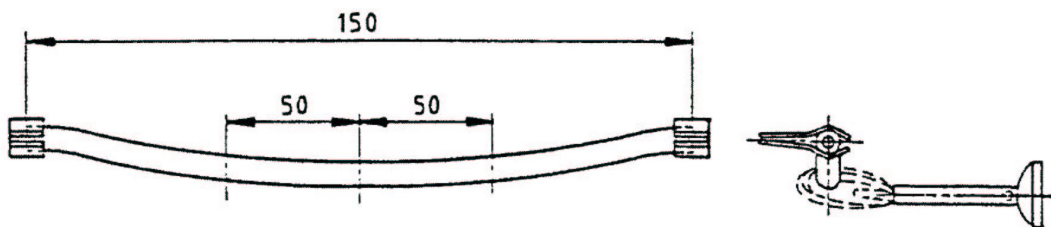

Dimensions are in millimetres.

Figure 3: Test for burning behaviour

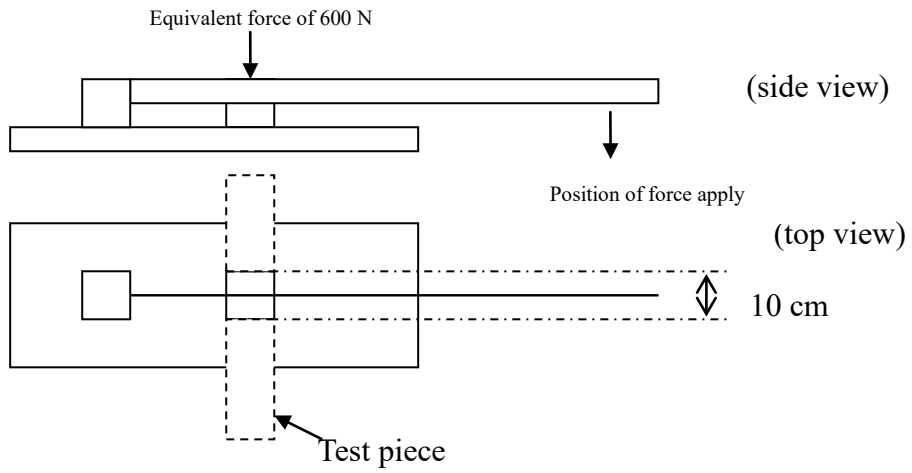

Figure 4: Resistance to crushing

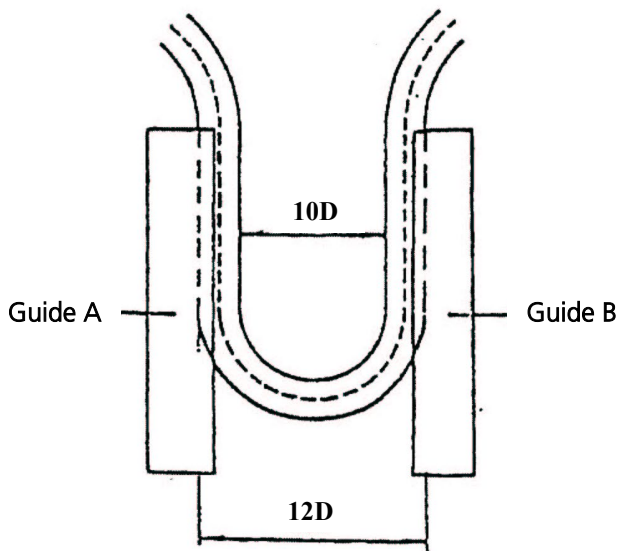

Figure 5

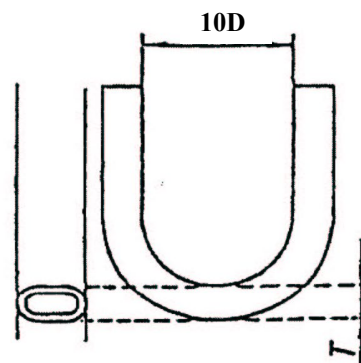
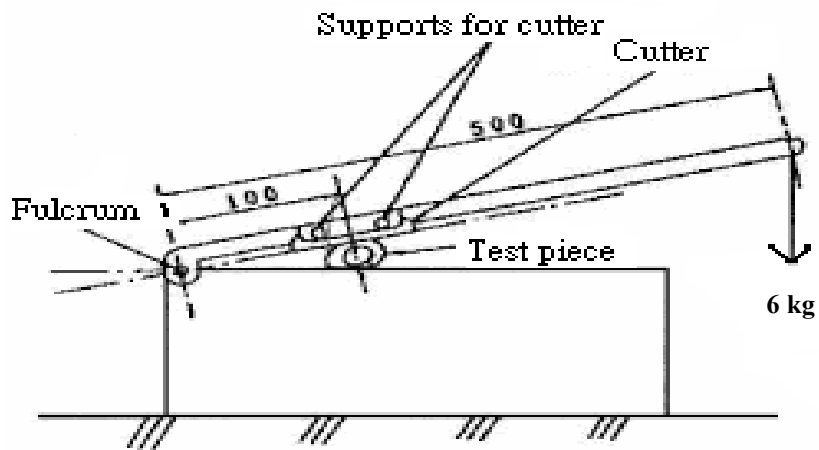

Figure 6

Figure 5 and Figure 6: Bending test



All dimensions are in millimeters.

Figure 7: Resistance to cutting

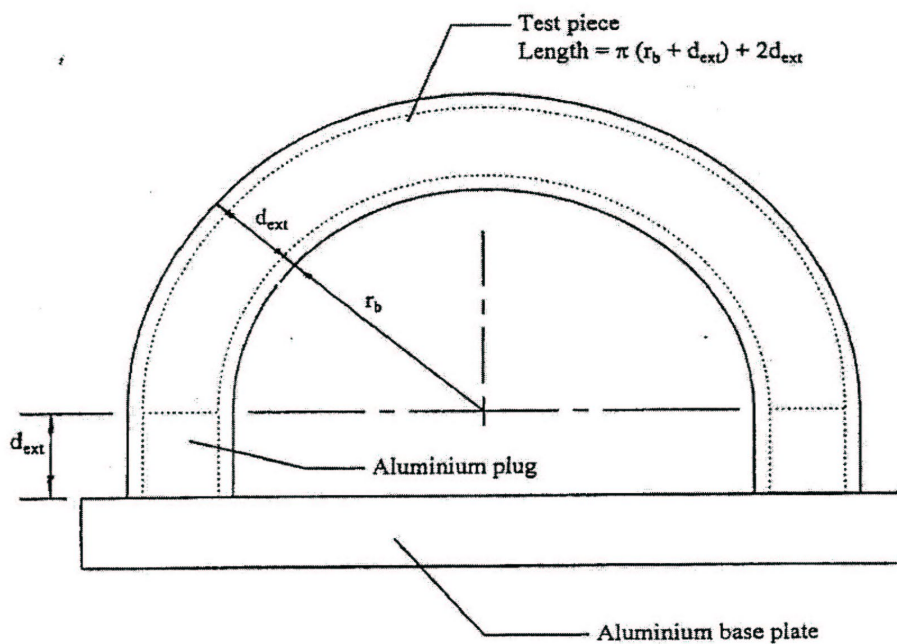

The length of the test piece shall be calculated by the formula

$$L = \pi (r_b + d_{ext}) + 2d_{ext}$$

where

L is the length of the test piece in mm;

r_b is the bend radius of the test piece in mm, which shall be equal to six times its internal diameter;

d_{ext} is the outside diameter of the test piece in mm.

Figure 8: Mounting of test piece for ozone resistance test

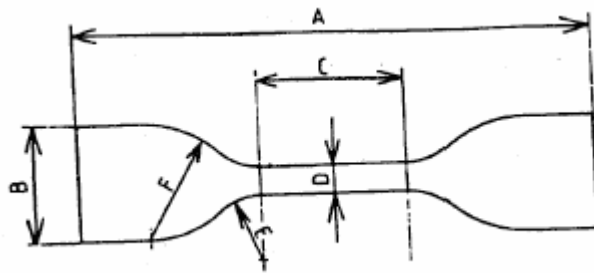

Total length, A (mm)	Width of ends, B (mm)	Length of narrow part, C (mm)	Width of narrow part, D (mm)	Small radius, E (mm)	Large radius, F (mm)
75	12.5±1.0	25±1.0	4±0.1	8±0.5	12.5±1.0

Figure 9: Dumb-bell test pieces used for tensile test