

Code of Practice for Fresh Water Cooling Towers

Part 1: Design, Installation and Commissioning



2023 Edition

EMSD 

**Code of Practice
For
Fresh Water Cooling Towers
Part 1: Design, Installation And Commissioning

2023 Edition
(October 2023)**

**Electrical and Mechanical Services Department
The Government of the Hong Kong Special Administrative Region**

Foreword

This Code of Practice was prepared to promote the proper use of fresh water cooling towers with guidelines for cooling tower design, installation, testing, commissioning, operation and maintenance in order to meet the energy efficiency objective with due consideration of the environment and health issues. It was developed by the Task Force which comprises members from eight government departments, three professional institutions and three trade unions on Code of Practice for Fresh Water Cooling Towers.

Part 1 of this series of Code of Practice for Fresh Water Cooling Towers (previously known as Code of Practice for Water-cooled Air Conditioning Systems) provides details on the design, installation and commissioning of cooling towers. It should be read in conjunction and made cross-reference with the followings:

Part 2 – Operation and Maintenance; and
Part 3 – Water Treatment Methods

Contents

	Page
Foreword	ii
Definitions	v
1. Introduction	1
1.1 Scope	1
1.2 Objectives	1
1.3 Applications	1
2. Cooling Tower Types and Cooling Tower Systems	3
2.1 General	3
2.2 Cooling Tower Types	3
2.3 Cooling Tower System	9
3. Cooling Tower Construction and Installation Requirements	11
3.1 Cooling Tower Shell	11
3.2 Intake Louvre	11
3.3 Fill	12
3.4 Fan and Fan Motor	12
3.5 Water Basin	13
3.6 Drift Eliminator	13
3.7 Water Distribution Pipework	14
3.8 Water Circulation Pipework	15
3.9 Water Sampling Point	15
3.10 Deflector	16
3.11 Silencer	16
3.12 Plume Abatement Measures	16
3.13 Access Opening	16
3.14 Cooling Tower Structure	17
3.15 Ladder and Handrail	17
3.16 Installation Access	17
3.17 Cooling Tower Supporting Framework	17
3.18 High Productivity Construction Method	18

Code of Practice for Fresh Water Cooling Towers

Part 1: Design, Installation and Commissioning

4.	Cooling Tower Installed Location	19
4.1	General	19
4.2	Cooling Towers installed on Building Roof	21
4.3	Cooling Towers installed on Podium Roof	21
4.4	Cooling Towers installed indoors with Vertical Discharge through Roof or Horizontal Discharge through Side Wall	22
4.5	Cooling Towers installed at Other Locations	22
4.6	Minimum Separation between Cooling Towers	23
4.7	Minimum Separation from Physical Barrier	23
4.8	Installation Location at a Composite Building (Residential and Commercial)	23
4.9	Installed Location not fulfilling the Required Minimum Separation	24
5.	Cooling Tower Water and Bleed-off Water Control	25
5.1	Cooling Water Quality Control	25
5.2	Bleed-off Control and Reuse of Bleed-off Water	25
6.	Notices and Labels	27
7.	Risk Management of a Cooling Tower System	28
7.1	General	28
7.2	Risk Management Plan	28
8.	Testing and Commissioning of Cooling Tower Systems	30
8.1	Testing and Commissioning	30
8.2	Occupational Safety and Health	30
9.	Design and Commissioning Records	31
10.	Qualification of a System Designer	32
11.	Reference Information	33
Appendices		
Appendix 1A –	A Typical Schematic Diagram of Fresh Water Cooling Tower Condensing Water Circuit	34
Appendix 1B –	Guidance Notes on Minimum Separation Requirements for Cooling Towers	35
Appendix 1C –	Samples of `Notices and Labels for Cooling Tower System	42
Appendix 1D –	A Standard Risk Management Plan for Fresh Water Cooling Tower System	43
Appendix 1E –	A Sample Checklist for Minimum Testing and Commissioning Procedures of Fresh Water Cooling Tower System	46
Appendix 1F –	A Recommended List of Personal Protective Equipment	48

Definitions

- Biocide** : A physical or chemical agent that kills bacteria and other microorganisms.
- Biodispersant** : A chemical compound added to the water inside cooling tower system, to penetrate and break down any biofilm that may be present on the wetted surfaces of the cooling tower system.
- Biofilm** : A surface layer of microorganisms. It is usually combined with particulate matter, scale and products of corrosion.
- Bleed off (blowdown)** : The removal of water from a cooling tower system to maintain the concentration of total dissolved solids and suspended solids in an acceptable level.
- Commissioning** : A systematic and progressive process of putting the components of a system into operation, calibrating instruments and controls, and then making adjustments and checks to ensure that the total system is providing satisfactory operation and performance.
- Cooling tower** : A device for lowering the temperature of water by evaporative cooling in which ambient air is in contact with falling water, thereby exchanging heat. The term also includes those devices that incorporate a water-refrigerant or water-water heat exchanger (evaporative condenser or closed-circuit cooling tower).
- Cooling tower system** : A heat exchange system comprising a heat-generating plant (chiller condenser or heat exchanger), a heat-rejection plant (cooling tower or evaporative condenser) and interconnecting water recirculating pipework and associated pumps, valves and controls. Cooling tower systems is considered as a part of WACS.
- Corrosion coupon** : Small strip of metal, usually placed into water circuits so that they can easily be removed, to enable the corrosion characteristics of the water to be assessed.
- Corrosion inhibitor** : Chemical which protects metals by: (a) passivating the metal by the promotion of a thin metal oxide film (anodic inhibitors); or (b) physically forming a thin barrier film by controlled deposition (cathodic inhibitors).
- Cycle of concentration** : The ratio between the concentration of dissolved solids in the cooling water and the concentration of dissolved solids in the make-up water as a result of the evaporation that takes place in the cooling tower.

- Dead leg : Water pipe with length equal to or larger than one diameter of the pipe, ending at a fitting through which water flows only when the fitting is opened. These extra areas of the cooling tower system contain stagnant water, which can cause building up of bacteria and sludge in recirculating system, and can then contaminate the system.
- Decontamination : A process used when a cooling tower system is found with a level of bacterial count which involves a series of actions to disinfect, clean and re-disinfect the cooling tower system.
- Disinfection : Preventive maintenance action of applying a treatment to a system, in conjunction with system cleaning, in order to reduce the general concentration of infectious agents.
- Dispersant : Reagent usually added with other treatment chemicals to prevent accumulation of sludge.
- Drift eliminator : A grid or grille-like arrangement of physical barriers located before the cooling tower exhaust designed to minimise the drift emanating from a tower.
- Drift : Water lost from the cooling tower as liquid droplets or aerosols entrained in the exhaust air, excluding condensation.
- Exhaust air outlet : A termination of a mechanical or natural ventilation system that allows air removed from a space and discharged outside the building. The exhaust air outlets, which are crucial in the consideration of separation distance with the cooling tower, are exhausts from kitchens, toilets, outlets of drainage vent pipes, generator flue discharge, carpark ventilation, fume cupboard and refuse collection room, and any exhaust that contains contaminants or nutrients for microbial growth in cooling water.
- Fan : A rotary machine which propels air continuously. This is used for moving air in a mechanical draft tower. The fan may be of induced draft or forced draft application.
- Fill (packing) : Material placed within cooling tower to increase heat and mass transfer between the circulating water and the air flowing through the tower.
- Filtration : The process of separating solids from a liquid by means of a porous substance through which only the liquid passes.
- Fouling : Organic growth or other deposits on heat transfer surfaces causing loss in efficiency.

Code of Practice for Fresh Water Cooling Towers

Part 1: Design, Installation and Commissioning

- Heterotrophic colony count (HCC) : The number of viable units of bacteria per millilitre of water sample. It is also known as Total Bacteria Count (TBC), Total Plate Count or Viable Bacteria Count.
- Legionnaires' disease : It is a type of bacterial pneumonia caused by legionella.
- Medical and health care premises : Hospitals, general clinics, specialist clinics; community support facilities for the elderly, such as residential elderly homes, social centre for the elderly; and establishments providing health care and services for the sick and infirm.
- Non-oxidising biocide : A non-oxidising biocide is one that functions by mechanisms other than oxidation, including interference with cell metabolism and structure.
- Operable window : An operable window is a window that has moving parts, such as hinges, and can be opened. If a window is permanently locked or required special tools to be opened, that window would not be considered as an operable window when examining the separation distance.
- Outdoor air intake : A termination of a mechanical or natural ventilation system that allows ambient air entering a building. The outdoor air intakes, which are crucial in the consideration of separation distance with the cooling tower, are fresh air intake for the air conditioning system of a building, and any air intake that draws outdoor air into the building. Vent pipe of water tanks are considered as outdoor air intake since its draw air from outdoor to the tank during discharge of water.
- Oxidising biocide : Agents capable of oxidising organic matter, e.g. cell material enzymes or proteins which are associated with microbiological populations resulting in death of the micro-organisms.
- Passivation : The formation of a protective film, visible or invisible, which controls corrosion.
- Plume : The visible discharge of air and moisture from a cooling tower due to condensation. It is usually most visible in cool and humid days when water vapour emanates from the cooling tower exhaust.
- Public accessible area : An area that is accessible by the public or building occupants other than building management/maintenance staff. Some of the examples are pedestrian thoroughfare/ footpath, place where people gather together for activities, accessible green roof/garden. Restricted area with proper access control which is only accessible by building management/maintenance staff is not considered as a public accessible area.

Code of Practice for Fresh Water Cooling Towers

Part 1: Design, Installation and Commissioning

- Podium Roof : Roof of the lower part of a building.
- Scale : A crystalline deposit that can form on surfaces or pipework within the cooling tower system due to building up of minerals (usually calcium carbonate).
- Scale inhibitor : Chemicals used to control scale. They function by holding up the precipitation process and/or distorting the crystal shape, thus preventing the build-up of a hard adherent scale.
- Sludge : A building up of sediment that can be found in the basin or pipework of a cooling tower system.
- Slug dosing/Shock dosing : The process of adding in a single dose a much higher amount of chemical biocide than is normally applied, with the intention of rapidly raising the concentration of biocide in the water to a level expected to kill most of the organisms in the water.
- Spray nozzle : A device used in an open distribution system to break up the flow of the circulating water into droplets, and effect uniform spreading of the water over the wetted area of the tower.
- Stagnant water : Pockets of motionless water within the cooling tower system that can allow microorganisms to grow.
- Temporary shut-down : Cooling tower temporarily shut-down is the entire/part of the system not in function and isolated from the main water-cooled condenser/heat exchanger to avoid contamination. Standby unit(s) with cooling water running once a week is not defined as temporary shut-down.
- Total legionella count : The number of legionella colony-forming units (CFU's) found in one millilitre of the water sample.

1. Introduction

1.1 Scope

This Part of the Code of Practice specifies the minimum requirements and good practices for the design, installation and commissioning of cooling tower systems. This outlines the prescriptive requirements to minimise health risk posing to the public by using cooling towers, and to maximise the system operating performance and reasonable energy efficiency in both design and construction stages. Emphasis has been put on the followings:

- a) System design and construction;
- b) Minimisation of water loss;
- c) Installed location of towers; and
- d) System commissioning.

1.2 Objectives

This Part of the Code of Practice aims at providing technical guidelines to every party involved in the design, installation and commissioning of cooling tower system so as to achieve the following objectives:

- a) Assure the public health and safety by preventing any potential risk associated with cooling towers system;
- b) Achieve better/maintain energy efficiency and operational performance of cooling tower system;
- c) Minimise nuisances caused by cooling tower system to the public;
- d) Prevent pollution and misuse of water;
- e) Assure occupational safety and health of the staff concerned.

1.3 Applications

1.3.1 This Code of Practice is intended for use by personnel who are responsible for the design, installation and commissioning of cooling tower systems, etc. It should be applied to the newly installed systems. Alteration and improvement work of the existing systems shall preferably be upgraded to comply with this version of CoP or at least continue to comply with the applicable versions at the time of the original system registration.

Code of Practice for Fresh Water Cooling Towers

Part 1: Design, Installation and Commissioning

- 1.3.2 This Code of Practice should be read in conjunction with any additional recommendations provided by suppliers/ manufacturers of the water treatment chemicals/ cooling tower equipment and any relevant specification and applicable ordinances and regulations in Hong Kong.
- 1.3.3 EMSD reserves the right to interpret the contents of this Code of Practice.
- 1.3.4 In case of conflict between the requirements of this Code of Practice and any other requirements, the following order of priority should apply:
- a) All currently in force Legislation and other Subsidiary Legislation.
 - b) The relevant Codes of Practice and Technical Standards.
 - c) This Code of Practice.

2. Cooling Tower Types and Cooling Tower Systems

2.1 General

Proper design of cooling tower system helps in reducing operational and maintenance problems as well as environmental impacts arising from system operation.

2.2 Cooling Tower Types

2.2.1 In general, cooling towers are classified based on their construction and air movement through the cooling tower in relation to the falling water droplets. Both natural draft and mechanical draft cooling towers are available in the market. Natural draft cooling towers do not use a mechanical air-moving device and all air movement through the cooling towers relies on the wind and stack effects. Mechanical draft cooling towers make use of mechanical fans to force ambient air flowing through the cooling towers. Evaporative condenser is heat rejection equipment which the working principle is similar to cooling tower, and should follow the requirements of this Code of Practice.

2.2.2 Both cooling tower and evaporative condenser use water as heat transfer medium to remove heat from the system. There are two basic types of evaporative cooling towers, namely direct-contact cooling tower and indirect contact cooling tower.

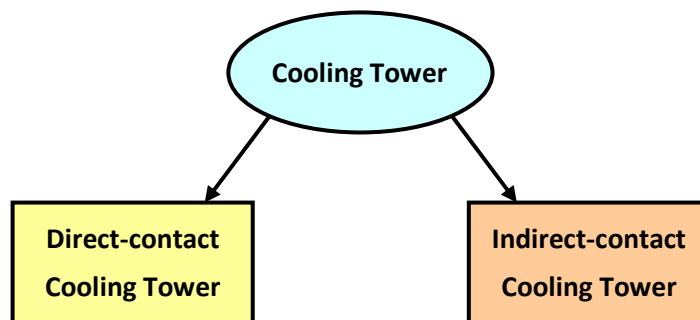

Figure 1.1: Classification of cooling tower

2.2.3 Direct-contact cooling tower

Direct-contact cooling tower (also known as open-circuit cooling tower) exposes water directly to the cooling atmosphere, hence transfers the heat from the cooling water directly to the air. Direct contact cooling towers can be further classified by their components' configuration and air draft mechanisms. In general, there are four different types (Figure. 1.2):

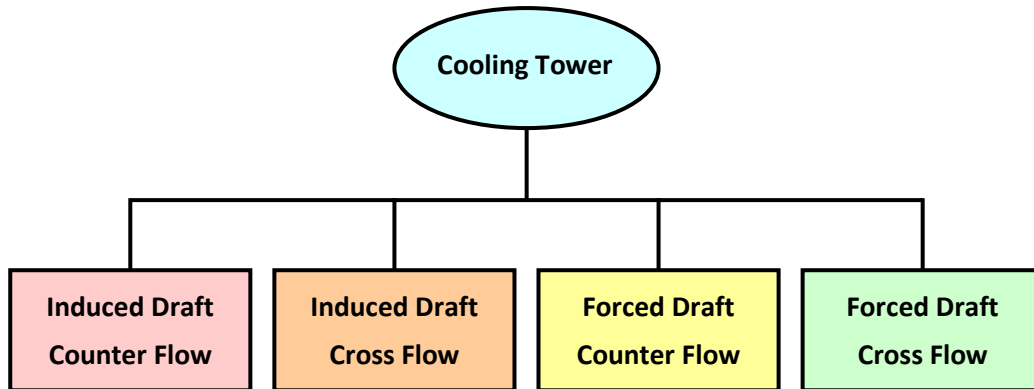

Figure 1.2: Types of direct-contact cooling towers

a) Induced Draft Counter Flow Type

Fan is installed inside cooling tower, which induces air to flow through louvre openings, pass through the fill and discharge through the fan. The fan pulls air up through the tower in the opposite direction to which the water is falling. Water is usually delivered by means of fixed or rotating spray arms. Drift eliminator is usually placed above the sprays to prevent loss of water through drift. This type of cooling tower can handle large heat rejection loads. Therefore, it is suitable for larger cell size and fan size. Larger fan size operating at low speed may result in greater efficiency and consequently lower power and sound levels. Typical configuration of induced draft counter flow cooling tower is shown in Figure 1.3.

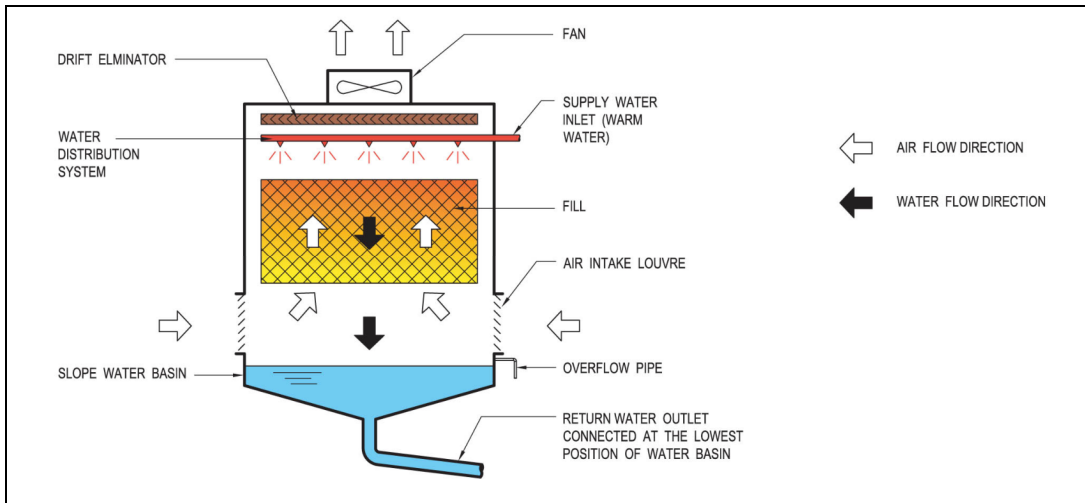

Figure 1.3: Typical configuration of induced draft counter flow cooling tower

b) **Induced Draft Cross Flow Type**

Fan is used to create an induced air flow into the cooling tower. Air is drawn or induced across the water falling from the top of the tower to the basin. This tends to give a more evenly distributed air flow through the fill, when compared with the forced draft design. Drift eliminator is installed vertically along the fill. Figure 1.4 illustrates the typical configuration of induced draft cross flow cooling tower.

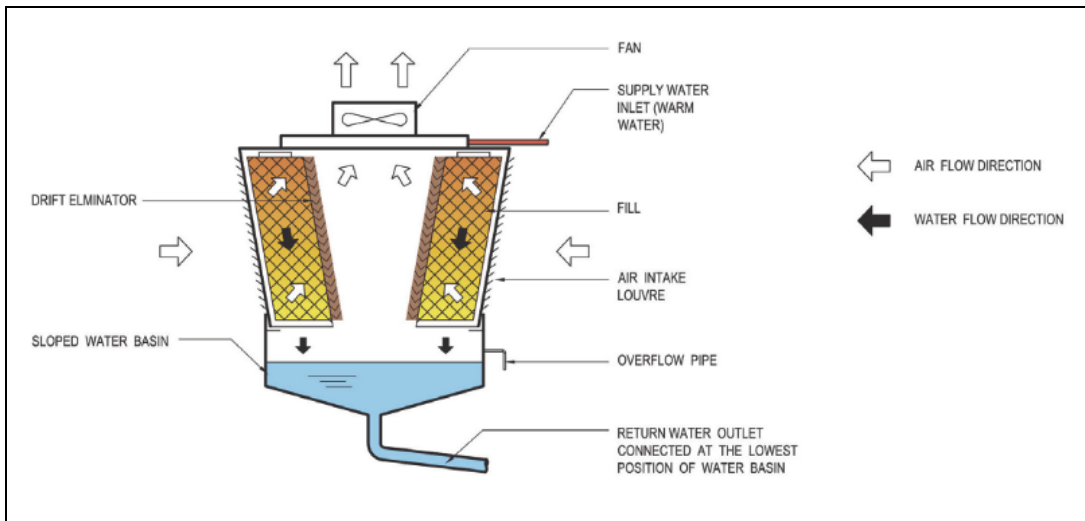

Figure 1.4: Typical configuration of induced draft cross flow cooling tower

c) Forced Draft Counter Flow Type

Fan is generally mounted at low level (inlet air side) of the cooling tower so that air can be forced upward through the fill. Axial or centrifugal fans can be used depending on external static pressure requirement and noise limit. Water sprays from the top of the cooling tower, which is in opposite direction to the air flow. Fan installed at low level tends to reduce the overall height of the tower and generate low vibration due to rotating components being located near the base of the tower. Fan unit is placed in a comparatively dry air stream; this reduces the problem of moisture condensing in the motor or gearbox. Figure 1.5 shows the typical configuration of forced draft counter flow cooling tower.

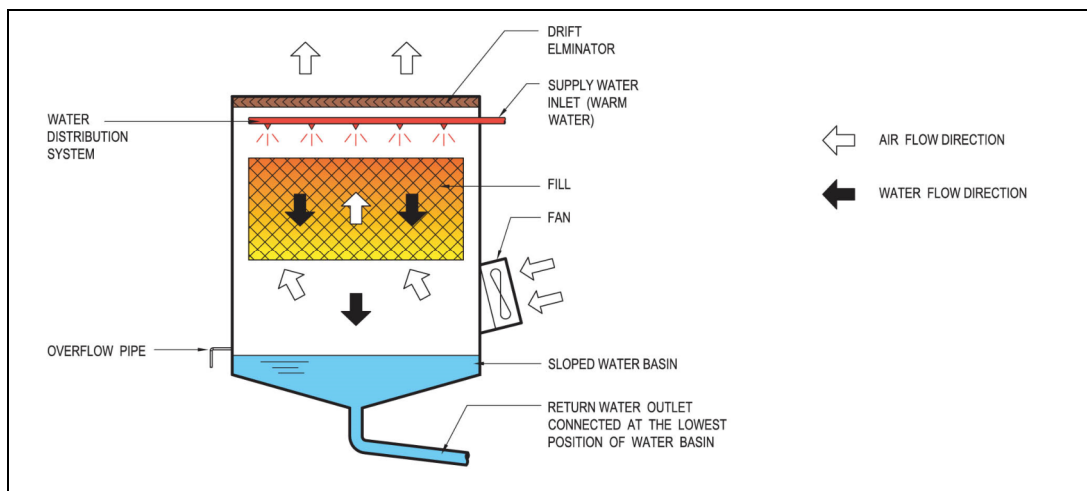

Figure 1.5: Typical configuration of forced draft counter flow cooling tower

d) Forced Draft Cross Flow Type

Fan is mounted on one side and air is forced through the fill horizontally with drift eliminators on the outlet side. This type of cooling tower is suitable for restricted headroom and low heat rejection capacity. Typical configuration of forced draft cross flow cooling tower is shown in Figure 1.6.

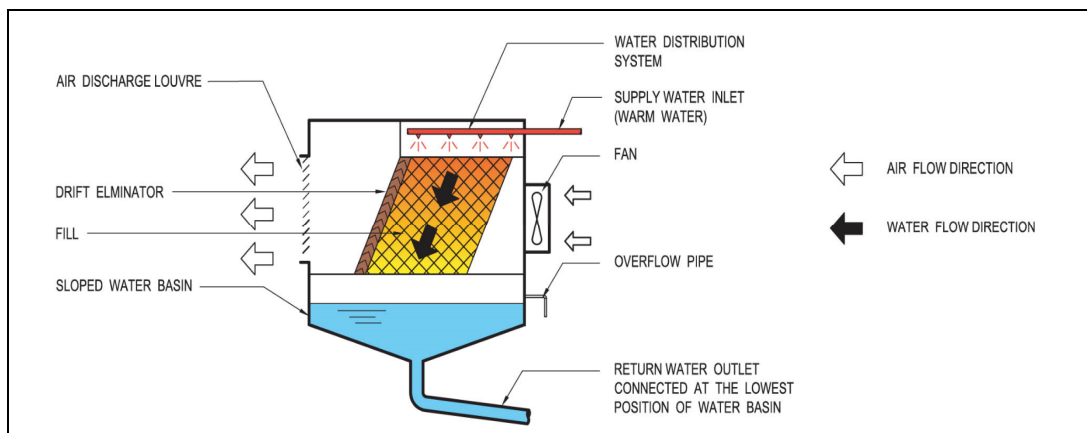

Figure 1.6: Typical configuration of forced draft cross flow cooling tower

2.2.4 Indirect-contact cooling tower

Indirect-contact cooling tower (also known as closed-circuit cooling tower) involves indirect contact between the fluid being cooled and the atmosphere, essentially combining a heat exchanger and cooling tower into one relatively compact device. The indirect-contact cooling towers, according to their fan configurations, can also be classified as induced draft counter flow, induced draft cross flow, forced draft counter flow and forced draft cross flow cooling towers. There are two separate fluid circuits in an indirect contact cooling tower. An external circuit allows water exposed to the atmosphere, while internal circuit consists of the tubes of coil bundle carrying fluid to be cooled. Heat flows from the internal fluid circuit, through the tube walls of the coil to external water circuit. Heat is then transferred to the atmospheric air. Figure 1.7 shows the typical configuration of closed-circuit cooling tower with no fill material.

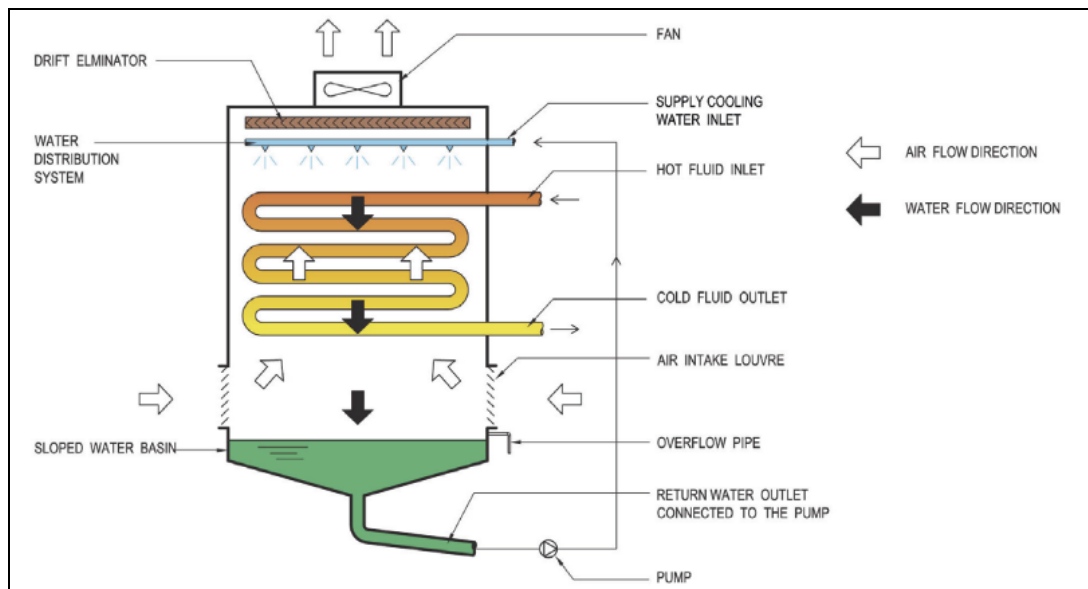

Figure 1.7: Typical configuration of closed-circuit cooling tower with no fill material

Coil Shed Cooling Tower

Coil shed cooling tower is indirect contact cooling tower which consist of isolated coil section located at the bottom. There is fill section above the coil section which air stream is directed only through the fill region. According to fan configurations, both counter-flow and cross-flow types are available. Figure 1.8 shows the typical configuration of coil shed cooling tower.

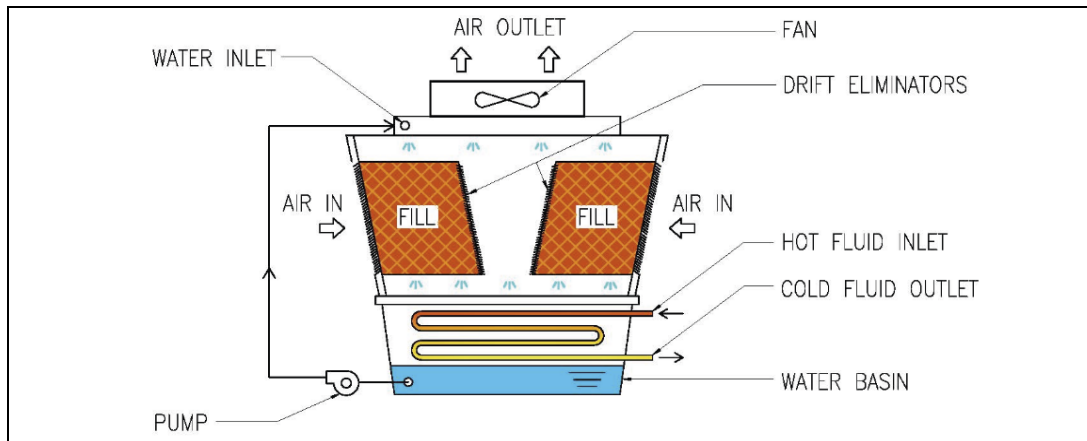

Figure 1.8: Typical configuration of coil shed cooling tower

2.2.5 Evaporative Condenser

The working principle of evaporative condenser is very similar to an indirect contact cooling tower, except that the refrigerant entering the tubes is in vapour state, which is subsequently cooled by the falling water. Vapour is condensed to liquid state by releasing heat to the falling water. Figure 1.9 illustrates the typical configuration of evaporative condenser.

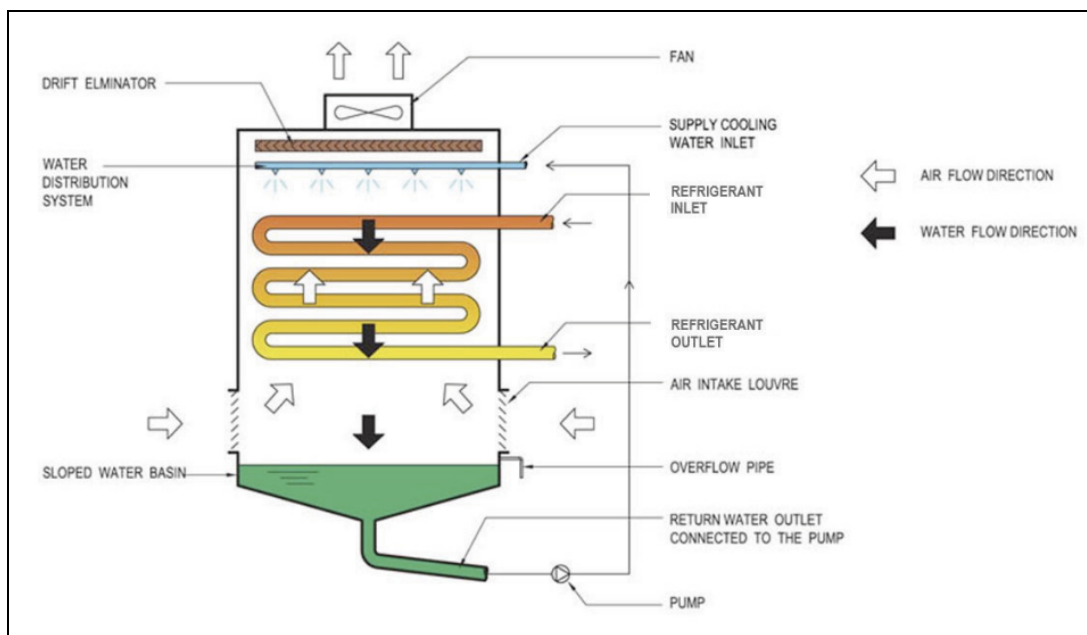

Figure 1.9: Typical configuration of evaporative condenser

2.3 Cooling Tower System

- 2.3.1 A typical cooling tower system consists of cooling tower, chiller condenser/ heat exchanger, water pump, chemical water treatment equipment, physical water treatment equipment, make-up water tank, bleed-off and drainage, pipework and fittings, metering devices, etc.. It is recommended to integrate the water treatment system to Internet of Things (IoT) water treatment controller with cloud-based water treatment management software or central server based Central Control and Monitoring System (CCMS)/ Building Management System (BMS) of the building. Major components in the system are elaborated in the following sections. A typical schematic drawing is shown in Appendix 1A.
- 2.3.2 Fresh water from the mains is commonly adopted by the cooling tower system.
- 2.3.3 Water pump(s) is installed for circulating water between the cooling tower and the condenser. Equalising pipe should be provided for multiple cooling tower installation to prevent overflow of cooling tower water from water basins.
- 2.3.4 Make-up water is required to compensate water losses due to evaporation, drift and bleed-off. Make-up water tank should be located at a level higher than the water inlet of cooling tower; otherwise, booster pump is required to provide sufficient static head for make-up water.
- 2.3.5 Water treatment systems, including but not limited to chemical and physical, are essential for a cooling tower system. They should be applied to tackle the problems of corrosion, scale and micro-organism growth, hence to enhance cooling tower water quality. Details should refer to the Code of Practice for Fresh Water Cooling Towers: Part 3 – Water Treatment Methods.
- 2.3.6 Water meters should be installed to record the total water consumption and the bleed-off volume of cooling tower. The make-up water consumption profile is a reasonable indicator to monitor any abnormal operational conditions of cooling tower.
- 2.3.7 Energy meter should be installed to measure the energy consumption by the entire cooling tower system. This gives information to the system owner and property manager regarding the monthly cumulative energy consumption, which is used to compare the trend and identify any abnormal operation.
- 2.3.8 Overflow pipe should be connected to the bleed-off water tank with a separate warning pipe being discharged into a conspicuous position.

- 2.3.9 Isolation valves should be installed for system with multiple cooling towers to facilitate cleansing and disinfection of individual cooling tower.
- 2.3.10 Provision of cleansing water point near cooling tower is recommended to facilitate cleaning of cooling tower.
- 2.3.11 It is recommended to adopt intelligent control system for cooling tower on/off and speed control. This system should also control the operation sequence, speed and temperature setting of other equipments in the chiller plant. The control system could take into account the real time outdoor air temperature, condensing and chilled water temperature, chiller Coefficient of Performance (COP), cooling demand and plume abatement requirement to obtain the operation mode with maximized overall energy efficiency.

3. Cooling Tower Construction and Installation Requirements

3.1 Cooling Tower Shell

- 3.1.1 Cooling tower shell is the external jacket of a cooling tower that attaches to the cooling tower framework. It is the structural component to ensure rigidity and integrity of cooling tower.
- 3.1.2 Cooling tower shell should be robust and constructed from non-corrosive and rigid material. It should not foster microbiological growth nor react adversely with water treatment, cleaning, disinfection and decontamination chemicals. The shell should withstand cooling tower structural load from internal components, including fill, framework, water basin as well as fan operation load, wind load and water pressure load. Also, it should structurally support the attachment of maintenance platform and ladders, as well as maintenance staff load.
- 3.1.3 Since cooling tower is usually installed outdoor, the casing should be weather resistant and opaque to sunlight. If cooling tower is installed indoor, fire-retardant material complying with the local fire services requirements should be used. All materials in the cooling tower system should be compatible to each other and should not deteriorate rapidly in a warm and moist environment.
- 3.1.4 Where feasible, cooling tower should be constructed, assembled and carried out performance test in the factory before delivered to site.

3.2 Intake Louvre

- 3.2.1 Intake louvre forms part of the cooling tower shell, which is used to retain circulating water and equalise air flow into the cooling tower.
- 3.2.2 Intake louvre should be designed to prevent water from spilling out and to obstruct direct sunlight from entering the cooling tower basin to minimise the growth of algae. For cross flow type cooling towers, two pass superior air inlet louvre screens constructed with corrosion free material can further eliminate water splashing out. Similar to cooling tower shell, material used should be weather resistant and opaque to sunlight. Fire-retardant material complying with the local fire services regulations should be used for cooling towers installed indoor.

- 3.2.3 In order to attenuate the noise emitted from cooling tower, acoustic louvres can be installed where necessary.

3.3 Fill

- 3.3.1 Fill is a major component in cooling tower to enhance heat and mass transfer and should be designed to provide maximum surface area for heat transfer process as the efficiency of cooling tower depends on the contact surface arrangement and contact time between air and water.
- 3.3.2 Fill must promote air-water contact while imposing the least possible restriction to air flow. Material used for fill should be durable, inert to chemical attack and fire-retardant. Fills should also be designed to facilitate cleaning and do not support bacteria growth.

3.4 Fan and Fan Motor

- 3.4.1 Fan is used to force or to draw air to pass through the tower with an electric motor as the drive. Either axial fan or centrifugal fan can be used in cooling tower depending on the system configuration and other technical requirements.
- 3.4.2 Cooling tower fan should have sufficient static pressure to encounter the internal static pressure and additional pressure drop due to silencer or deflector.
- 3.4.3 Fan blades should be set to the same pitch to avoid unbalanced aerodynamic forces. Since fan is operated in moisture-laden atmosphere, all materials should be corrosion resistant. If gearbox is equipped for the fan, it should also be waterproof to prevent the incursion of cooling water.
- 3.4.4 Fan motor should be of water-proof type and operate under high humidity condition. Two-speed motor or Variable Speed Drive (VSD) Motor is recommended to allow cooling tower fan speed to be varied in responding to different heat rejection load. Also, motor insulation must withstand thermal aging, moisture, expansion and contraction stresses, electrical stress, mechanical vibration and shock.

3.5 Water Basin

- 3.5.1 Water basin is located at the bottom of cooling tower to collect all cooled water from the tower; therefore, it is in contact with water all the times once the cooling tower is in operation.
- 3.5.2 In order to prevent accumulation of dirt and particulates, the basin must be smooth, without dirt trapping pattern, accessible, cleanable, provided with adequate drain facilities and screening equipment. Materials used for basin should be non-corrosive, rigid and easy to clean. Basin sweeping system with nozzles installed around the bottom of basin could be considered to further prevent accumulation of suspended solids and building up of sludge. The basin sweeping system could be integrated with the side stream filtration system.
- 3.5.3 Basin should be watertight and has adequate fall to allow water flowing to the drain point. Drainage outlet size depends on capacity of cooling tower, but should not be less than 50 mm of internal diameter, and should be provided at the lowest point of the basin to facilitate complete drain.
- 3.5.4 Basin should have sufficient water depth of at least two velocity head measured above the top level of water outlet in order to prevent vortex forming at the water outlet and inducing excessive quantities of air. Alternatively, anti-vortex plate, sparge pipe or large diameter outlet may be used to reduce velocity below the free surface.
- 3.5.5 Screen should be installed at the bottom level of the sump to filter large impurities, such as leaves, so as to prevent blockage of the pump. Installation of side-stream filtration is a good practice to allow cleaning during continuous operation.
- 3.5.6 Condenser water pipework above the level of the basin should be kept to a minimum to avoid air ingress and loss of water when system is temporarily shut down.

3.6 Drift Eliminator

- 3.6.1 Drift eliminator removes entrained water from the discharged air by allowing air to have sudden changes in direction. The resulting centrifugal force separates the water droplets from the air, lets the water droplets attach to the eliminator surface and allows them to return to the cooling tower basin.

- 3.6.2 Efficiency of drift eliminator depends on the number of directional airflow changes, spacing between the blade surface, angle of directional change and the capability of drift eliminator blade to return the collected water to a quiescent area of the plenum. Drift eliminators can be characterised by their shapes and configuration. Common types of drift eliminators include cellular (honeycomb), herringbone (blade-type) and waveform.
- 3.6.3 Drift eliminator should be provided and installed in each cooling tower to facilitate ease of inspection, cleaning and maintenance. It should be extended across the air stream without air bypass. Drift eliminator should be made from materials with good corrosion resistance. It should be durable and can withstand cleaning by water jet.
- 3.6.4 Drift eliminator should be effective at the air velocity prevailing when the cooling tower is in operation. Attention should be paid to ensure drift eliminator is well seated and fixed closely against one another with no gaps where the air stream can bypass the baffle.
- 3.6.5 Drift emission of the drift eliminator installed in cooling tower should not exceed **0.002%** of the maximum design water circulation rate through the cooling tower. Drift emission test should be carried out under design maximum air flow and maximum water flow conditions of the drift eliminator being tested. A test certificate or supporting documents, which clearly states the test method and the testing conditions, should be provided to prove the performance of the drift eliminator under the specified testing conditions.
- 3.6.6 The drift loss performance of the drift eliminator should remain at its design level within its life cycle.

3.7 Water Distribution Pipework

- 3.7.1 Gravity-flow distribution and pressure-type system are two common water distribution systems used inside cooling tower. Gravity-flow distribution consists of distribution plate with closely and evenly separated orifices. Water is turned into small droplets when flowing through the orifices and distributes to the fill. Pressure-type system consists of pipes and spray nozzles, which generate a water spray pattern to allow water spray evenly passing over the fill.

- 3.7.2 In order to prevent formation of algae due to direct sunlight, cooling tower adopting water distribution system should be covered by ultra-violet resistant materials. Materials used for pipes, spray nozzles and distribute plates should be rigid, corrosion resistant and do not proliferate bacteria growth.

3.8 Water Circulation Pipework

- 3.8.1 Cooling tower water circulation system pipework should be designed to avoid dead-leg and stagnant corners. Simple pipework design should be adopted. If the installation involves more than one cooling tower, balance pipe between the cooling towers should be provided.
- 3.8.2 If the existence of dead-leg cannot be avoided, mitigation measures for dead leg should be provided, such as installation of manual/automatic drain valve for periodic drain off.
- 3.8.3 Provision of recirculating pump controlled by a timer to circulate water through the system periodically (at least once a week) is recommended when cooling towers are temporary not in use. Purge valve installed at end of pipe riser can avoid stagnant water as well.
- 3.8.4 Drain pipe with manual/automatic on/off valve should be provided to each cooling tower for routine cleaning and emergency decontamination.

3.9 Water Sampling Point

- 3.9.1 In order to facilitate water sampling, sampling taps should be provided at the cooling tower system. One sampling tap, for collecting water samples of cooling water, should be fitted at the pipework where the warmed water enters the cooling towers. Another sampling tap should be installed at the system for collecting water samples of bleed-off water.
- 3.9.2 The pipework of the sampling tap should not be excessively long and should be positioned as close to the main pipe as possible so as to avoid the problem of dead leg.
- 3.9.3 Water sampling tap can also be located at the cooling water return line, but not adjacent to make-up water inlets or dosing points.

3.10 Deflector

Deflector is to divert exhaust air to a specific direction. It is recommended to install deflector on cooling tower located in the area, where the exhaust from cooling tower may directly affect the adjacent air intakes and openings, creating a short-circuit problem of cooling tower air flow or causing nuisance to nearby sensitive receivers.

3.11 Silencer

Silencer should be provided if the noise emitted during operation of cooling tower exceeds the limit stated in the Noise Control Ordinance and Technical Memorandum for the Assessment of Noise from Places other than Domestic Premises, Public Places or Construction Sites issued by the Environmental Protection Department.

3.12 Plume Abatement Measures

Plume abatement measures should be adopted in the cooling tower to minimise the plume caused by the condensation of the discharged air from cooling tower if the plume is considered as nuisance to the surroundings. Most air conditioning systems are under partial-load condition during this period. Advanced distribution of heat rejection capacity among the cooling towers or other supplementary measures could be adopted for plume abatement.

Plume abatement measures may be provided by:

- (i) Performing load sharing among cooling towers;
- (ii) Allowing extra heat rejection capacity of cooling tower system to operate the cooling tower system in partial-load condition;
- (iii) For cooling towers with fan speed control, optimising the cooling tower fan speed control to meet plume abatement with energy efficient strategy during partial-load condition;
- (iv) Introducing by-pass air (heated or non-heated ambient air) to the cooling tower before discharge to the atmosphere, etc.; or
- (v) Installing heat recovery type heating coil.

3.13 Access Opening

Access door with minimum dimensions of 600mm (width) × 1 000mm (height) is recommended for cooling tower to facilitate inspection and maintenance of inner part of the tower. If no access door is provided due to tower construction constraints, easy dismantle of cooling tower shell should be allowed for maintenance work.

3.14 Cooling Tower Structure

The structure of cooling tower must accommodate dead loads imposed by the weight of cooling tower and circulating water, as well as wind load and maintenance load. It must maintain its integrity throughout a variety of external atmospheric conditions. Overall cooling tower weight should be taken into account in the design of the building structure.

3.15 Ladder and Handrail

Ladder and handrail should be provided to facilitate routine cleaning, maintenance and inspection. Cooling tower should be equipped with maintenance platform with toe board, ladders and permanently fixed access to the level for carrying out normal maintenance. Sufficient safety provision is required if maintenance work is potentially to be carried out at high level.

3.16 Installation Access

Cooling tower system should be designed to allow easy and safe access for routine cleaning, water sampling, inspection and maintenance.

3.17 Cooling Tower Supporting Framework

The supporting frame for cooling tower and similar installations are building works subject to the control of the Buildings Ordinance and subsidiary regulations. Authorized Person should be appointed to obtain the prior approval of plans and consent for commencement of works from the Building Authority (BA). Simplified procedures under the Minor Works Control System (MWCS) may be adopted under certain circumstances. For the details of the MWCS, please refer to website of the Buildings Department (BD) at <https://www.bd.gov.hk> and the latest "General Guidelines on Minor Works Control System", "Technical Guidelines on Minor Works Control System" and "Minor Works Control System Supporting structures for building services installation, ventilation ducts and radio base stations" published by the BD. In addition, there are Designated Exempted Works (DEW) under the MWCS, which can be carried out on prescribed conditions without obtaining prior approval and consent from the BA nor following the simplified requirements of the MWCS. Details of the DEW are listed in Schedule 2 of the Building (Minor Works) Regulation.

The frame should not affect lighting and ventilation and not to project over streets. The supporting plinth of cooling tower should refer to manufacturers' recommendation in order to prevent deformation due to incorrect plant load.

3.18 High Productivity Construction Method

High Productivity Construction Methods such as Multi-trade integrated Mechanical, Electrical and Plumbing (MiMEP) could be considered cooling tower installation. By adopting off-site prefabrication, such as the MiMEP approach, on-site operation could be minimized, which could shorten installation time at site, reduce material waste, improve quality control and enhance site safety. The position of mounting frame should be reviewed carefully to ensure the maintenance access and clearance will not be compromised.

Condenser water pipes and cooling towers are recommended to be pre-assembled in sectional modules for modular construction subject to its weight, dimensions, transportation and site conditions. The sectional modules may cover composition of cooling tower units, pipe headers, straight pipes, bends, cladding, valves, fittings, pump set modules, associated electrical and control accessories, metering facilities, steel frame, hanger fixing, provision of vibration isolation accessories and maintenance platform, where applicable.

4. Cooling Tower Installed Location

4.1 General

4.1.1 The cooling tower should be installed at an optimum location to minimise any nuisance causing to nearby occupants. The works of cooling towers shall be in full compliance with the Buildings Ordinance.

4.1.2 Any cooling tower should not be placed to protrude beyond the boundary of the lot.

4.1.3 Cooling tower should not affect the floor loading, natural lighting and ventilation, escape access to alternate staircases and be of no contravention of the Buildings Ordinance.

4.1.4 Minimum Separation Requirements

(a) Horizontal Separation Distance

The minimum horizontal separation measured from the cooling tower exhaust and cooling tower intake to the nearest critical outdoor air intake, exhaust air outlet, operable window and public accessible area on its own building and adjacent buildings should comply with the horizontal separation requirements as shown in Table 1.1. Illustration of horizontal separation measurement could be referred to Appendix 1B - Figure B1 & Figure B2.

Table 1.1: Minimum horizontal separation distance from cooling towers

Horizontal Separation Distance				
	Critical Outdoor air intake (m) ^{Note1}	Critical Exhaust air outlet (m) ^{Note2}	Operable window (m) ^{Note3}	Public accessible area (m) ^{Note4}
Cooling tower exhaust	7.5	7.5	7.5	7.5
Cooling tower intake	5	7.5	5	5

Note:

1. Critical outdoor air intake refers to fresh air intakes of the building air conditioning systems (e.g. primary air unit, air handling unit, lift vent) or any intake that draws fresh air into the occupied area or vent pipe of water tanks.
2. Critical exhaust air outlet refers to kitchen exhaust, toilet exhaust, car park exhaust, food processing exhaust, laboratory exhaust, outlet of drainage vent pipe, generator flue discharge or any exhaust that can contaminate the cooling water or pollute the cooling air.
3. Operable window refers to window that has moving parts, such as hinges, and can be opened. (Refer to definitions.)
4. Refer to Section 4.1.5 for detail description of public accessible area.
5. Opening and natural outlet are regarded as exhaust.

(b) Vertical Separation Distance

If the minimum horizontal separation distance stated in Table 1.1 cannot be compiled, minimum vertical separation requirements listed in Table 1.2 and 1.3 should be followed. Illustration of vertical separation measurement could be referred to Appendix 1B - Figure B3 & Figure B4.

Table 1.2: Minimum vertical separation distance above cooling towers

Vertical Separation Distance (above cooling tower)				
Location: above the cooling tower	Critical outdoor air intake (m)	Critical exhaust air outlet (m)	Operable window (m)	Public accessible area (m)
Cooling tower exhaust	20	20 ^{Note1}	20	20
Cooling tower intake	5	7.5	5	5

Note:

1. If the critical exhaust air outlet is interlocked with non-return damper, or alike, to prevent infiltration when the exhaust system is not in operation, the exhaust outlet should be distant from the cooling tower exhaust with a minimum of 7.5m separation.

Table 1.3: Minimum vertical separation distance below cooling tower

Vertical Separation Distance (below cooling tower)				
Location: below the cooling tower	Critical outdoor air intake (m)	Critical exhaust air outlet (m)	Operable window (m)	Public accessible area (m)
Cooling tower exhaust	7.5	7.5	7.5	9.3 (7.5+1.8 ^{Note1})
Cooling tower intake	5	7.5	5	6.8 (5+1.8)

Note:

1. 1.8m above ground is counting for breathing zone for pedestrian. Examples could be referred to Appendix 1B – Figure B4.

4.1.5 No public accessible area should be located within 7.5m horizontal separation distance from the cooling tower exhaust and 5m horizontal separation distance from the cooling tower intake. Public accessible green roof is considered as public accessible area, same separation requirements are applied. Special arrangement for the cooling tower installation could be considered for satisfying the separation requirements. Examples could be referred to Appendix 1B – Figure B5 to B7.

4.1.6 If the exhaust air from a cooling tower system discharges towards a louvre or an opening, a deflector or an air ductwork should be provided to divert the exhaust air from cooling tower to an appropriate direction.

- 4.1.7 If the cooling tower is installed outdoors with an extended ductwork for exhaust air, measurement should be taken from the exhaust termination of the ductwork. If the cooling tower is installed in an enclosed cooling tower plant room, measurement should be taken from the exhaust/intake termination of the cooling tower plant room. Illustration of separation measurement could be referred to Appendix 1B - Figure B8 & Figure B9.
- 4.1.8 If cooling tower is installed below an extended podium, a minimum horizontal separation of 7.5m between the edge of the extended podium and the nearest edge of plant room's opening/ louvre should be maintained. Otherwise, the building blocks and accessible area on the podium should be distant from the edge of the podium with a minimum of 7.5m separation. Illustration of separation measurement could be referred to Appendix 1B - Figure B10.
- 4.1.9 The prevailing wind condition should be considered to determine if the cooling tower exhaust will create nuisance to the third party (including the occupants inside a building and the surroundings).

4.2 Cooling Towers installed on Building Roof

- 4.2.1 Cooling tower installed on building roof should maintain adequate separation from the nearest outdoor air intake, exhaust air outlet, operable window, public accessible area as stipulated in Section 4.1, so that the drift and air emitted from the cooling tower will not enter the building through the outdoor air intake and operable window or the exhaust air from the building will not become the cooling air for the cooling tower.

4.3 Cooling Towers installed on Podium Roof

- 4.3.1 Cooling tower installed on podium roof is possibly to be surrounded by residential blocks, which may affect the air flow pattern and dispersion of drift within that region. Therefore, cooling tower location should be carefully selected so that exhaust air, drift and plume generated from cooling tower would not cause nuisance to the residents.

- 4.3.2 Cooling tower installed on podium roof should maintain adequate separation from the nearest outdoor air intake, exhaust air outlet, operable window, public accessible area as stipulated in Section 4.1, so that the drift and air emitted from the cooling tower will not enter the building through the outdoor air intake and operable window or the exhaust air from the building will not become the cooling air for the cooling tower.
- 4.3.3 In all cases, cooling tower exhaust air should be discharged away from building operable windows and outdoor air intakes.

4.4 Cooling Tower installed indoors with Vertical Discharge through Roof or Horizontal Discharge through Side Wall

- 4.4.1 Cooling tower if located indoor should be installed in a designated plant room. The plant room should not be accessible by public.
- 4.4.2 The fire resisting construction for cooling tower plant room and penetrations of associated pipework/ductwork through fire resisting walls/slabs should be in full compliance with the Buildings Ordinance.
- 4.4.3 Sufficient fresh air should be provided to maintain normal operation of cooling tower systems.
- 4.4.4 For cooling tower with vertical discharge through roof or horizontal discharge through side wall, the minimum separation distance from the cooling tower exhaust to the outdoor air intake, operable window, and public accessible area should meet the requirements as stipulated in Section 4.1.

4.5 Cooling Towers installed at Other Locations

If the horizontal separation distance between the cooling tower exhaust and the domestic buildings or medical and health care premises is within 20m, applicants should carry out a technical assessment and submit a copy of technical assessment report to the EMSD with the satisfaction of EMSD. The technical assessment report should include plume abatement report, master layout plans indicating nature of surrounding buildings, separation distance between cooling towers and domestic buildings or medical and health care premises, etc., in order to substantiate the proposed installation location of cooling towers are situated at an optimum location with minimal nuisance causing to the nearby residents/ occupants. The exhaust of cooling tower should be facing upwards or appropriate direction to avoid direct facing to the nearby occupants.

4.6 Minimum Separation between Cooling Towers

Separation distance between cooling towers installed adjacent to each other should refer to technical recommendations provided by cooling tower manufacturers. The minimum separation should be kept in order to ensure the heat rejection performance of cooling towers is not affected. If no recommendation from the manufacturer is given, the minimum separation distance should not be less than the lateral width of the cooling tower.

4.7 Minimum Separation from Physical Barrier

Obstruction of fresh air intake for cooling tower may have adverse influence to heat rejection performance. Minimum separation requirement between cooling tower and physical barrier as recommended by cooling tower manufacturers should be followed. If no recommendation from the manufacturer is given, the minimum separation distance should not be less than the lateral width of the cooling tower.

4.8 Installation Location at a Composite Building (Residential and Commercial)

- 4.8.1 If the cooling tower is installed at an composite building (residential and commercial), an applicant should also carry out a technical assessment and submit a copy of technical assessment report to EMSD with the satisfaction of EMSD in addition to satisfying the minimum separation distance requirements as specified in Section 4.1. The technical assessment report should include plume abatement report, master layout plans indicating nature of surrounding buildings, separation distance between cooling towers and domestic buildings or medical and health care premises, etc., in order to substantiate the proposed installation location of cooling towers are situated at an optimum location with minimal nuisance causing to the nearby residents/occupants.
- 4.8.2 The preferred installation location of cooling towers should be distant from the domestic block the farthest, and cause the least nuisance to the residents and nearby occupants.
- 4.8.3 Cooling tower exhaust air should be discharged away from buildings' operable windows and outdoor air intakes. The location of cooling tower should be at an optimum location to minimise nuisance to nearby occupants.

- 4.8.4 If horizontal separation distance between the cooling tower exhaust and the domestic buildings or medical and health care premises is within 20m, the exhaust of cooling tower should be facing upwards or appropriate direction to avoid direct facing to the nearby occupants.
- 4.8.5 Plume abatement measure should be adopted for cooling towers which are installed in composite building. Plume abatement report endorsed by the owner of the cooling tower system should be submitted at the initial project design stage.
- 4.8.6 Risk management plan for the cooling tower system should be prepared and submitted with the application by the owner/designer of the cooling tower system. For detail of Risk Management Plan, refer to Section 7.2 of Part 1 of this Code of Practice.

4.9 Installed Location not fulfilling the Required Minimum Separation

The requirements of minimum separation as specified in the Section 4.1 should be satisfied in normal circumstance. In the event that the requirement on minimum separation cannot be met, alternative mitigation measures can be provided by system owner/designer to minimise any potential risk with substantiation for consideration. Computational Fluid Dynamics (CFD) simulation may be used to assist in providing justification in critical case.

5. Cooling Water and Bleed-off Water Control

5.1 Cooling Water Quality Control

5.1.1 General

Good cooling water quality of cooling towers can minimise scaling and biofouling problems such that effective heat exchange in condenser/heat exchanger can be maintained. The Part 3 of this Code of Practice provides details of water treatment for cooling towers.

5.1.2 Cooling water quality

- a) Fresh water cooling tower system should be properly designed to achieve the relevant water quality targets as described in the tables in the Part 2 of this Code of Practice.
- b) Quality of cooling water discharged from cooling tower system should comply with the requirements stipulated in the EPD's Technical Memorandum on Standards for Effluent Discharged into Drainage and Sewerage Systems, Inland and Coastal Waters. It should be noted that the effluent discharge requirement may vary with the discharge flow rate.

5.2 Bleed-off Control and Reuse of Bleed-off Water

5.2.1 General

Bleed-off is required to maintain the concentration of total dissolved solids (TDS), insoluble precipitates, other chemical constituents and pH value of cooling tower at an acceptable level. Bleed-off is preferred to be performed automatically by a conductivity sensor. Bleed-off immediately after chemical dosage should be avoided to minimise chemicals wastage. Timer Control or manual bleed-off is not preferred unless automatic bleed-off by a conductivity sensor is not practicable.

5.2.2 Bleed-off water quantity

In order to prevent water wastage, the minimum cycle of concentration in designing water treatment program and bleed off requirement should not be less than six (6) for fresh water cooling tower system. Drainage system should be designed based on the estimated bleed-off quantity.

5.2.3 Bleed-off water quality

The quality of bleed-off water from cooling tower should satisfy the standard specified in the Technical Memorandum on Standards for Effluent Discharged into Drainage and Sewerage System, Inland and Coastal Waters issued under the Water Pollution Control Ordinance. Other standards that are set for toxic metals should also be complied with.

5.2.4 Reuse of bleed-off water

- a) The bleed-off water from cooling tower should be reused for flushing purpose by discharging it to a retention tank before transferring it to the flushing water tank or discharging it directly to the flushing water tank. In both cases, the retention tank or the flushing tank should be designed to store bleed-off water discharged by the cooling tower of not less than two hours of operation. If bleed-off water is directly discharged to the flushing water tank, adequate capacity in the flushing water tank should be reserved to prevent overflowing. In both cases, the bleed-off water should be prioritised to refill the flushing tank.
- b) WSD's quality requirements for flushing water should be referred to Table 2.2 in Part 2 of the Code of Practice. If the bleed-off water quality is found beyond the water quality requirements as listed in the Table 2.2, the flushing water at distribution should be regularly checked and closely monitored for compliance. The bleed-off water may be treated when necessary to achieve the stated water quality criteria for flushing supply at distribution.
- c) In case of bleed-off water cannot be fully utilised for flushing, owners or designer of the cooling tower should propose other alternatives for the arrangement of utilising the bleed-off water for the satisfaction of relevant authorities.

5.2.5 Bleed-off water directly discharged to public sewerage system

Direct discharge of bleed-off water should not be made to the public sewerage system in the physical arrangement. The owner / designer of the cooling tower system should submit an application for not reusing bleed-off water for flushing to the satisfaction of the relevant authorities in order to obtain a special permission. In case the bleed-off water is not reused for flushing, wholly or partially, a retention tank may be required to be installed to withhold the bleed-off water for discharge to the public sewerage at the time to be agreed by the relevant authorities. For application of the licence for the discharge of bleed-off water, please refer to the FWCT Scheme Brochure.

6. Notices and Labels

- 6.1 All cooling towers, water treatment equipment, water tanks and pipeworks should be properly labeled to provide clear indication for operation and maintenance personnel.
- 6.2 A nameplate engraved with EMSD registration number should be provided for each cooling tower.
- 6.3 Warning signs should be erected to alert operation and maintenance personnel of the potential hazard caused by cooling tower.
- 6.4 Warning signs should also be erected to restrict unauthorised access to cooling towers.
- 6.5 Labels and signs should be durable and securely fixed/marked on the following location. The English and Chinese characters of the labels and signs should be at least 8mm and 15mm high respectively.
 - a) Outside cooling tower apparatus area/room;
 - b) Outside chiller plant and condensing water pump area/room;
 - c) Make-up pipe;
 - d) Bleed-off pipe;
 - e) Condensing water supply & return pipe;
 - f) Dead-leg purge valve;
 - g) Water sampling valve/tap;
 - h) Water treatment product handling area;
 - i) Cooling water quality control station;
 - j) Make-up condensing water tank;
 - k) Bleed-off water break tank; and
 - l) Flushing water tank.
- 6.6 Samples of notices and labels could be referred to Appendix 1C.

7. Risk Management of a Cooling Tower System

7.1 General

If cooling tower system is installed in medical and health premises and any other premises which are considered necessary, a risk management plan for the cooling tower system should be developed and the risk management plan should be endorsed by the owner of the cooling tower system.

7.2 Risk Management Plan

7.2.1 The risk management plan for the cooling tower system should be prepared when designing the cooling tower system or whenever necessary. In developing risk management plan for complicated cooling tower systems, consultation with experienced system designers, cooling tower suppliers, water treatment service provider, operation and maintenance (O&M) contractor of cooling tower and occupational hygienists is suggested.

7.2.2 The general guidelines for developing a risk management plan for a cooling tower system are shown below.

- a) To provide the site and key contact details of the cooling tower system.
- b) To identify, but not limited to, the following risk that are potentially found in a cooling tower system
 - Stagnant water
 - Nutrient growth
 - Poor water quality
 - Deficiencies in the cooling tower system
 - Location and access
- c) To assess the above risks if they are found in the respective cooling tower system.
- d) To recommend the mitigation measures if the above risks are found in the respective cooling tower system.
- e) To formulate an operational programme based on the above risk assessment results and recommended mitigation measures. The contents should at least include frequencies of inspection, service, cleaning, disinfection, HCC testing and legionella testing.

- f) To provide a communication plan in case the cooling tower system is required to be attended urgently, such as positive Legionella testing results, complaints from the public, etc.
- g) To provide a procedure for monitoring and reviewing the Risk Management Plan.

7.2.3 Risk management plan should be submitted along with the application to use cooling towers in the air conditioning system or whenever requested by EMSD.

7.2.4 A standard risk management plan is shown in Appendix 1D for reference.

7.2.5 Risk management plan is required to be reviewed under the following circumstances:

- a) Results of checks indicate that mitigation measures are ineffective; or
- b) If a case of Legionnaires' disease is associated with a building.

8. Testing and Commissioning of Cooling Tower Systems

8.1 Testing and Commissioning

Testing and commissioning of cooling tower should be witnessed by a registered professional engineer (RPE) in Building Services or Mechanical discipline. A sample checklist for testing and commissioning of cooling tower system can be referred to Appendix 1E.

8.2 Occupational Safety and Health

- 8.2.1 The employers or occupiers must ensure safety and health at work of all employees under the Occupational Safety and Health Ordinance.
- 8.2.2 Sufficient personal protective equipment should be provided to the personnel responsible to carry out testing and commissioning work of a cooling tower system. Recommended list of personal protective equipment required related to different job nature is shown in Appendix 1F.
- 8.2.3 Eye wash bottles or washing basin with fresh water tap should be provided adjacent to water treatment chemicals tanks or any appropriate location for emergency use. The water contained in the eye wash bottle should be replaced periodically.
- 8.2.4 Water treatment chemical should be stored at an appropriate location to facilitate chemical handling.
- 8.2.5 Mechanical/natural ventilation should be provided to the room entirely/partially used for water treatment chemical storage.
- 8.2.6 Electrical fittings and luminaries serving water treatment chemical storage area should be weather-proof and corrosion resistant type.

9. Design and Commissioning Records

9.1 Formal design and commissioning records of a cooling tower system should be kept by the cooling tower owner for the whole life of the system. The records should be made available for inspections upon request by Government appointed officials. The record should include, but not limited to the following:

- a) The name, contact phone and address of the owner of the cooling tower system;
- b) The name, contact phone and address of the cooling tower designer, who is responsible for the design of the cooling tower system;
- c) The name, contact phone and address of the cooling tower contractor, who is responsible for the installation, testing and commissioning of the cooling tower system;
- d) Design details of the cooling tower system;
- e) Descriptions of the cooling towers and water treatment equipment, including their locations, technical specifications, models, capacities and year of manufacture/installation as well as correct operation procedure;
- f) Testing results of all equipment in the cooling tower system; and
- g) Water sampling results.

9.2 The operation and maintenance (O&M) manual of the cooling tower system should be prepared by the O&M contractor of cooling tower and kept by the owner of cooling tower system. The O&M manual should at least consist of the followings:

- a) Technical details of all equipment in a cooling tower system, including drawings of the plant, equipment and systems;
- b) System schematic and layout plan showing the locations of cooling towers and the nearby openings in the building and the adjacent buildings;
- c) Manufacturers' recommendations on operation and maintenance of all equipment in the cooling tower system;
- d) A programme for routine chemical treatment, cleaning, desludging and disinfection of the cooling tower;
- e) Details of water chemicals used for water treatment;
- f) Recommended cleaning methods and dismantling instructions; and
- g) Start-up, operating and shut-down procedures.

10. Qualification of A System Designer

A fresh water cooling tower system should be designed by a registered professional engineer (RPE) in Building Services or Mechanical discipline.

11. Reference Information

11.1 The following Ordinances, Technical Memorandum and Code of Practice should be compiled with in the design, installation and commissioning of cooling towers:

- Waterworks Ordinance (WWO) (Cap. 102)
- Buildings Ordinance (BO) (Cap. 123)
- Sewage Services Ordinance (SSO) (Cap. 463)
- Water Pollution Control Ordinance (WPCO) (Cap. 358)
- Air Pollution Control Ordinance (APCO) (Cap. 311)
- Noise Control Ordinance (NCO) (Cap. 400)
- Occupational Safety and Health Ordinance (OSHO) (Cap. 509)
- Public Health and Municipal Services Ordinance (PHMSO) (Cap. 132)
- Buildings Energy Efficiency Ordinance (BEEO) (Cap. 610)
- Technical Memorandum on Standards for Effluent Discharged into Drainage and Sewerage System, Inland and Coastal Waters, EPD
- Technical Memorandum for the Assessment of Noise from Places other than Domestic Premises, Public Places or Construction Sites, EPD
- Fresh Water Cooling Towers Scheme, EMSD
- Code of Practice for the Prevention of Legionnaires' Disease, PLDC

11.2 It is advised that designers should check other relevant statutory requirements and seek the professional advice from a Licensed Plumber, an Authorized Person (AP) and a Registered Professional Engineer (RPE) of Building Services or Mechanical disciplines when they have queries in the standard of work required.

Appendix 1A

Typical Schematic Diagram of Fresh Water Cooling Towers Condensing Water Circuit

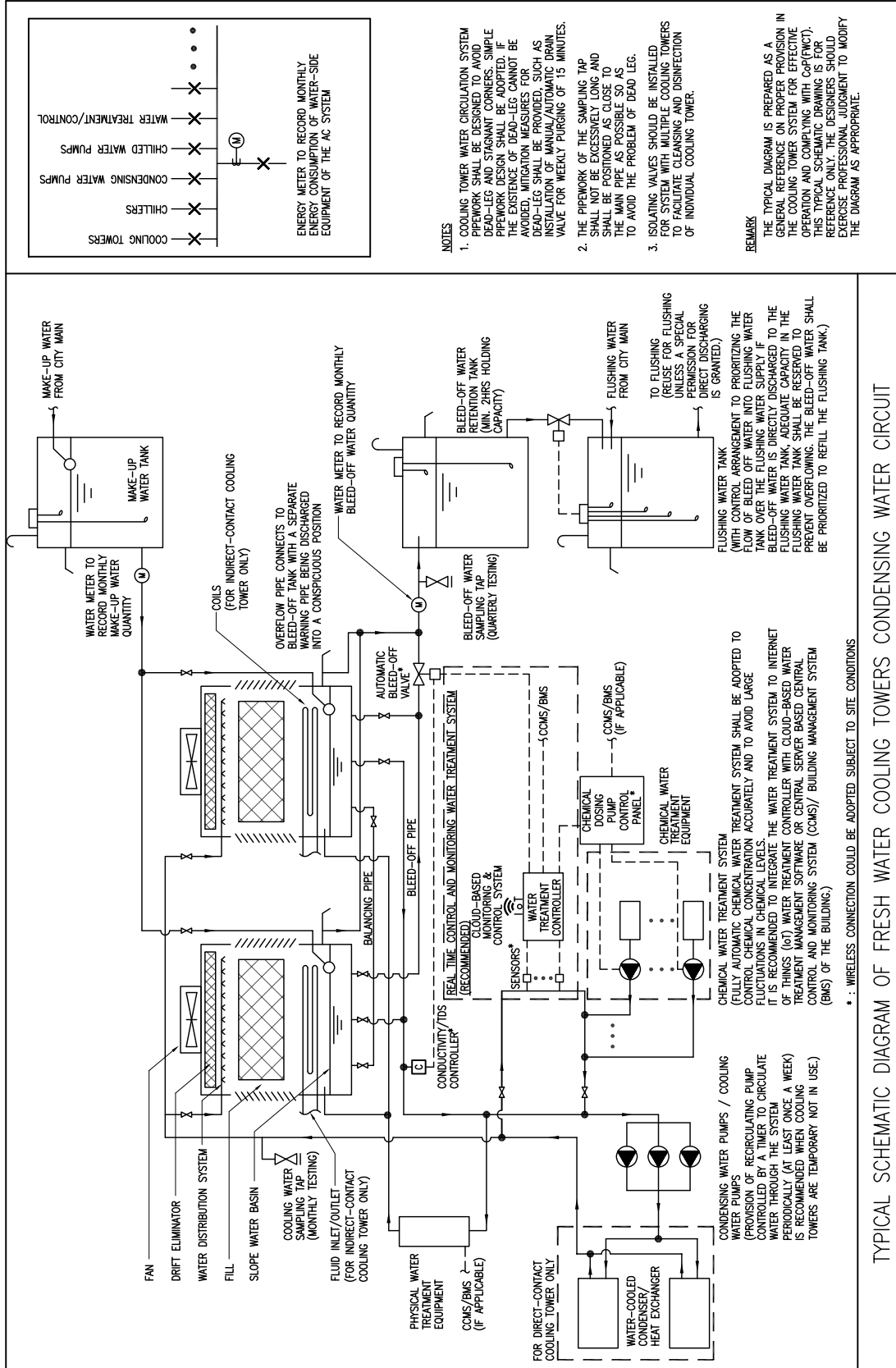

Appendix 1B

Guidance Notes on Minimum Separation Requirements for Cooling Towers

B1 - General Separation Measurement

The minimum horizontal separation should be measured from the nearest edge of the cooling tower exhaust / intake to the nearest edge of the outdoor air intake, exhaust air outlet or operable window. Also, horizontal distance should be considered separately from the vertical distance and they should not be summed up together or used directional distance to meet the minimum separation requirement. The figures below illustrate some common misinterpretations with respect to the requirement of this Code of Practice.

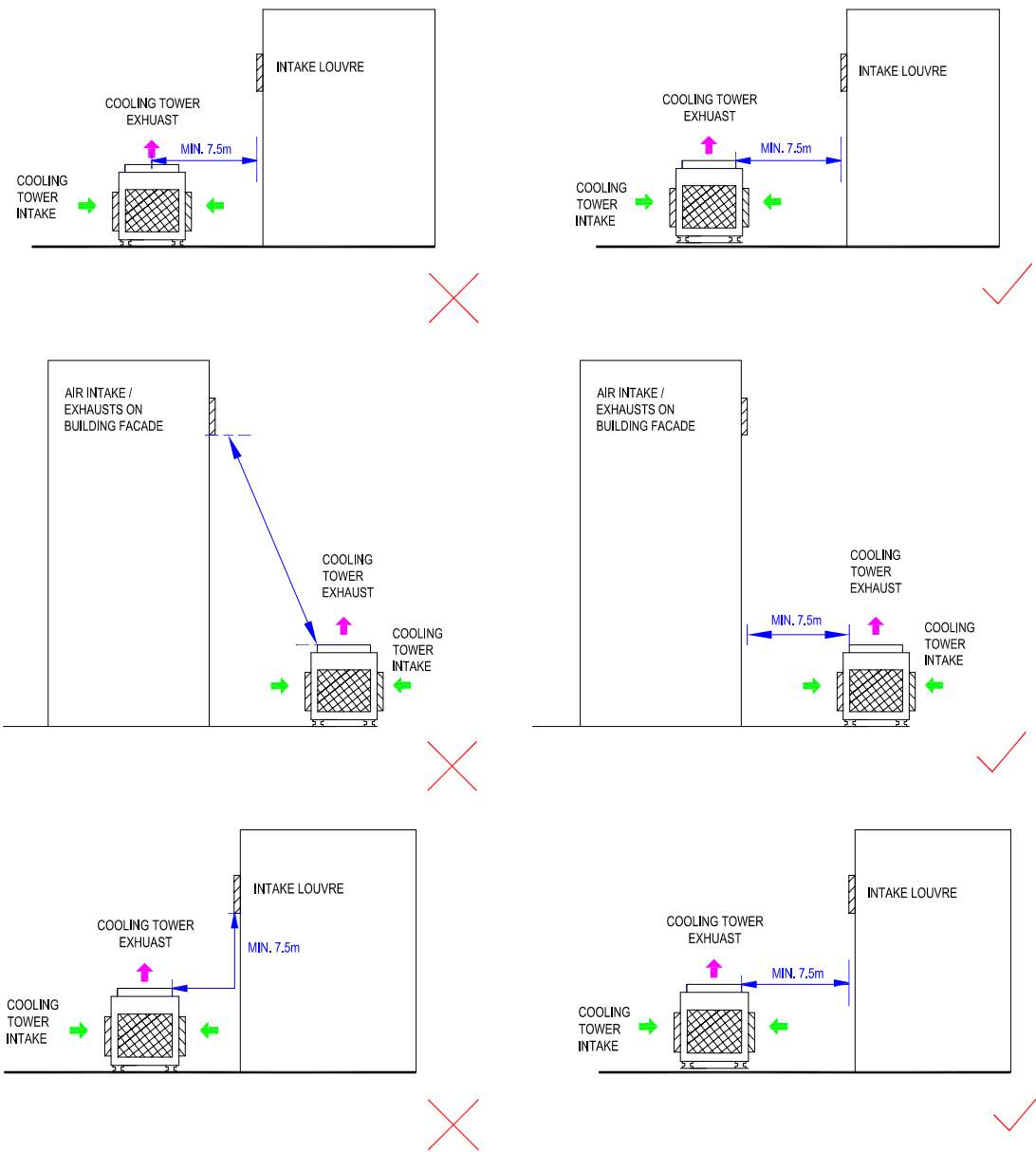

Figure B1 – General Separation Measurement

B2 – Minimum Horizontal and Vertical Separation

(Details refer Section 4.1.4)

B2.1 - Horizontal Separation

The cooling tower's exhaust/ intake louvre should be distant from critical louvres/ operable windows/ public accessible area (including public accessible green roof) with minimum horizontal distance as shown in Figure B2.

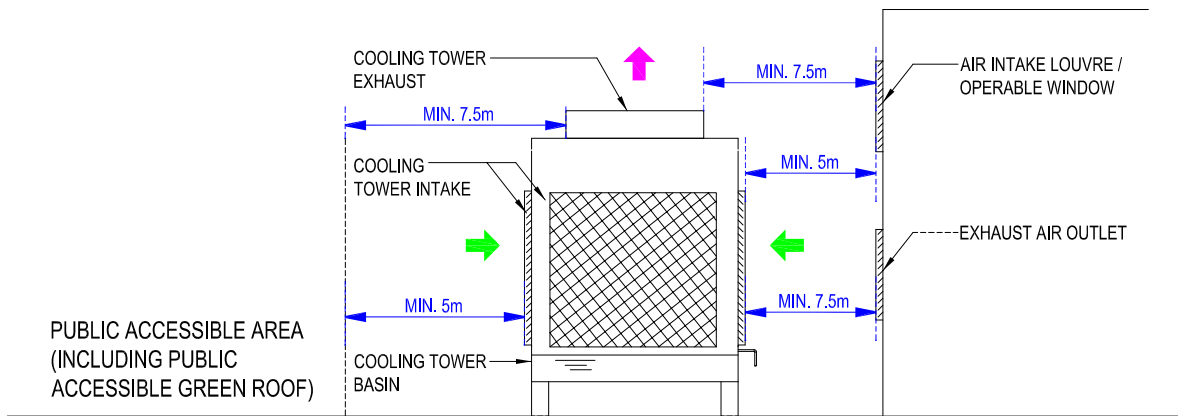

Figure B2 – Horizontal Separation

B2.2 - Vertical Separation

If the minimum horizontal distance cannot be complied, minimum vertical separation distance as shown in Figure B3 and Figure B4 should be fulfilled.

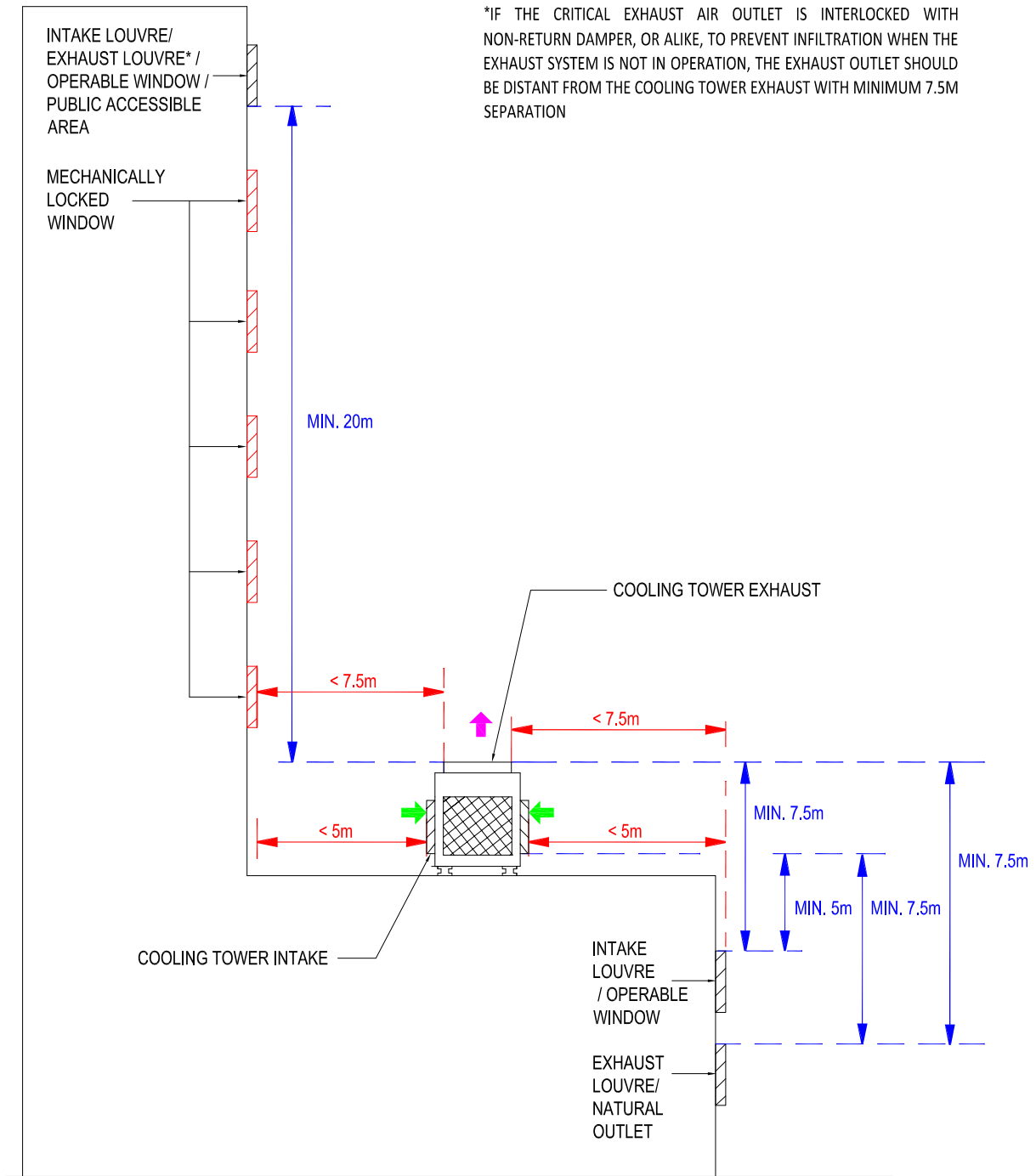

Figure B3 – Vertical Separation

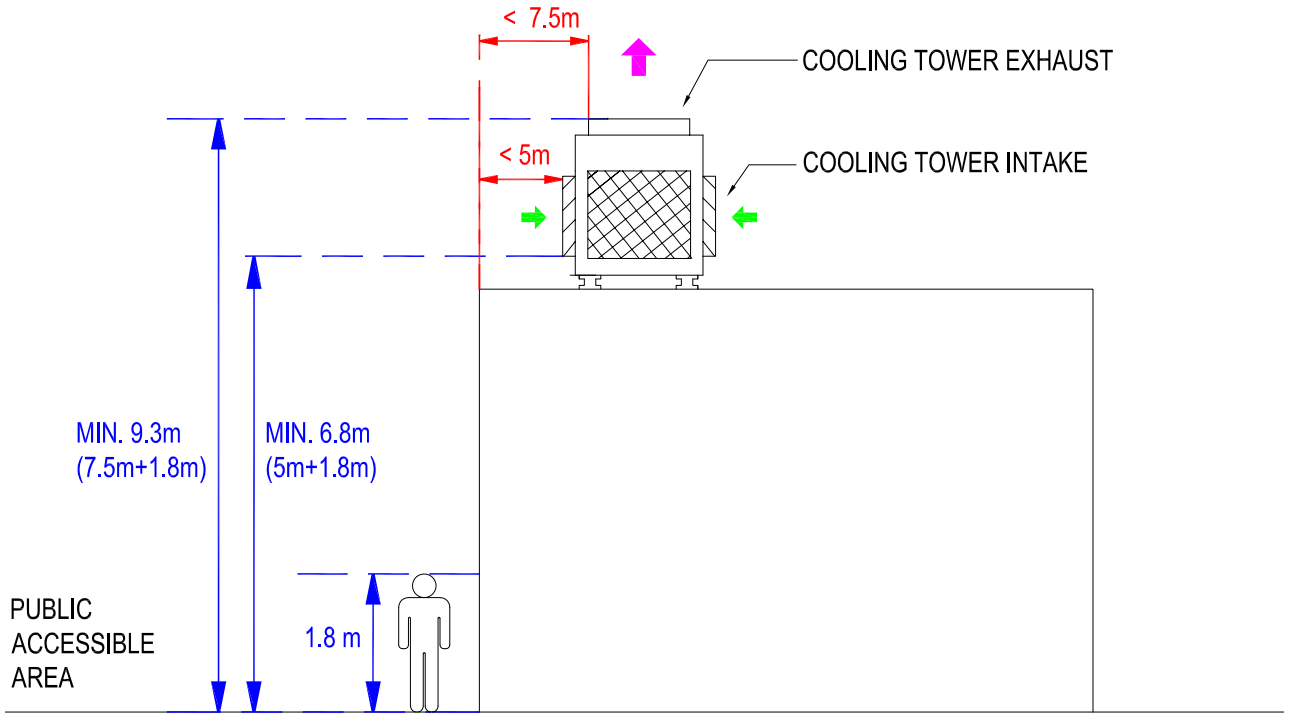

Figure B4 – Vertical Separation with public accessible area

B3 – Reference Cases

B3.1 - Special Arrangement for meeting the minimum separation requirements

(Refer to Section 4.1.5)

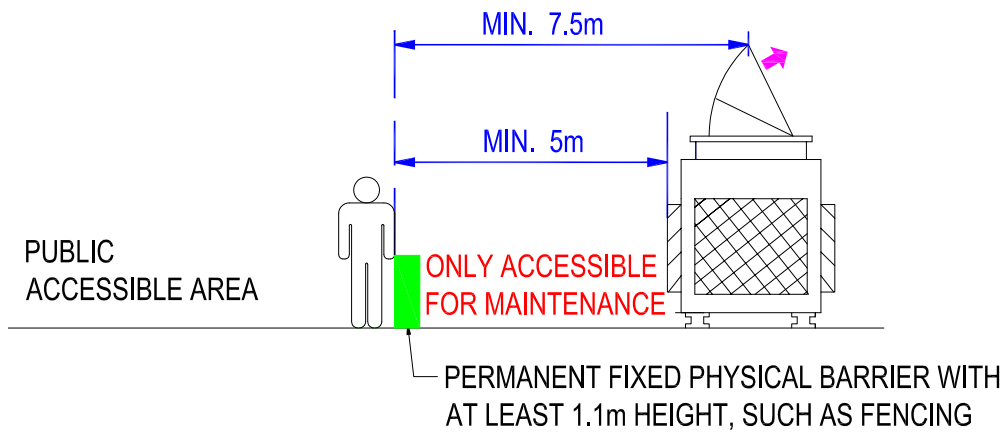

Figure B5 – Provision of permanent fixed physical barrier

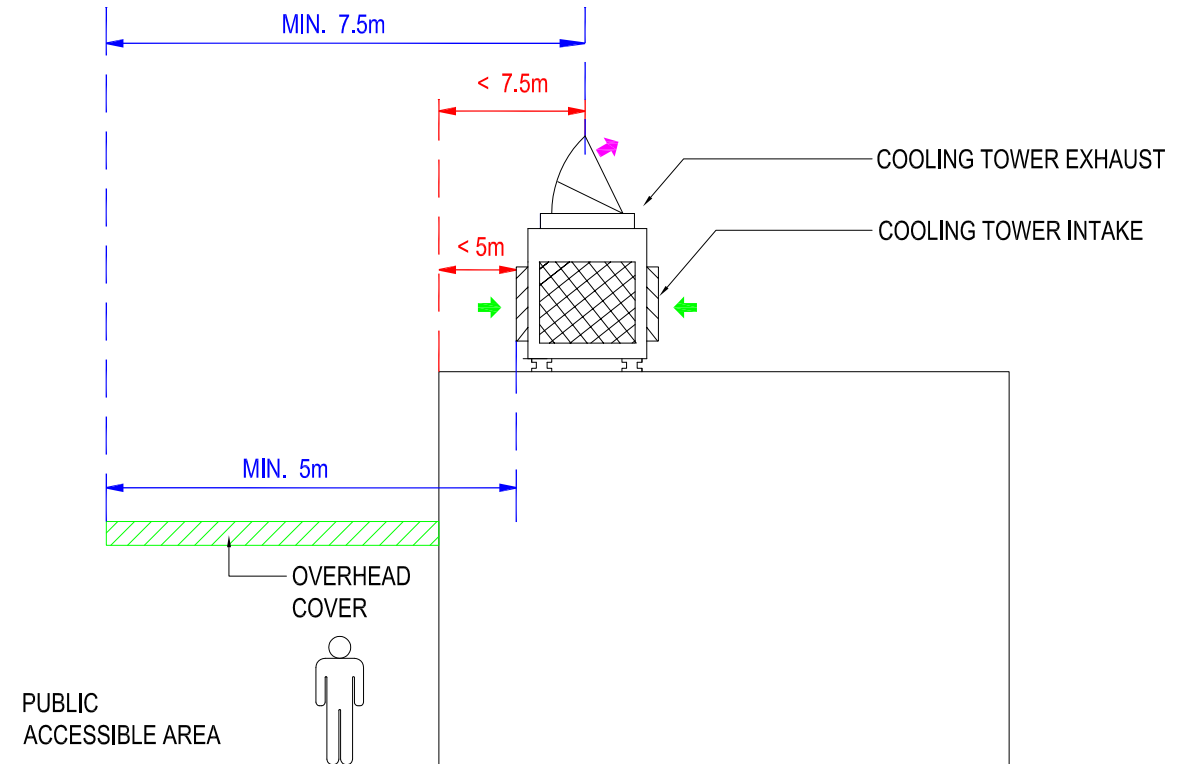

Figure B6 – Provision of overhead cover

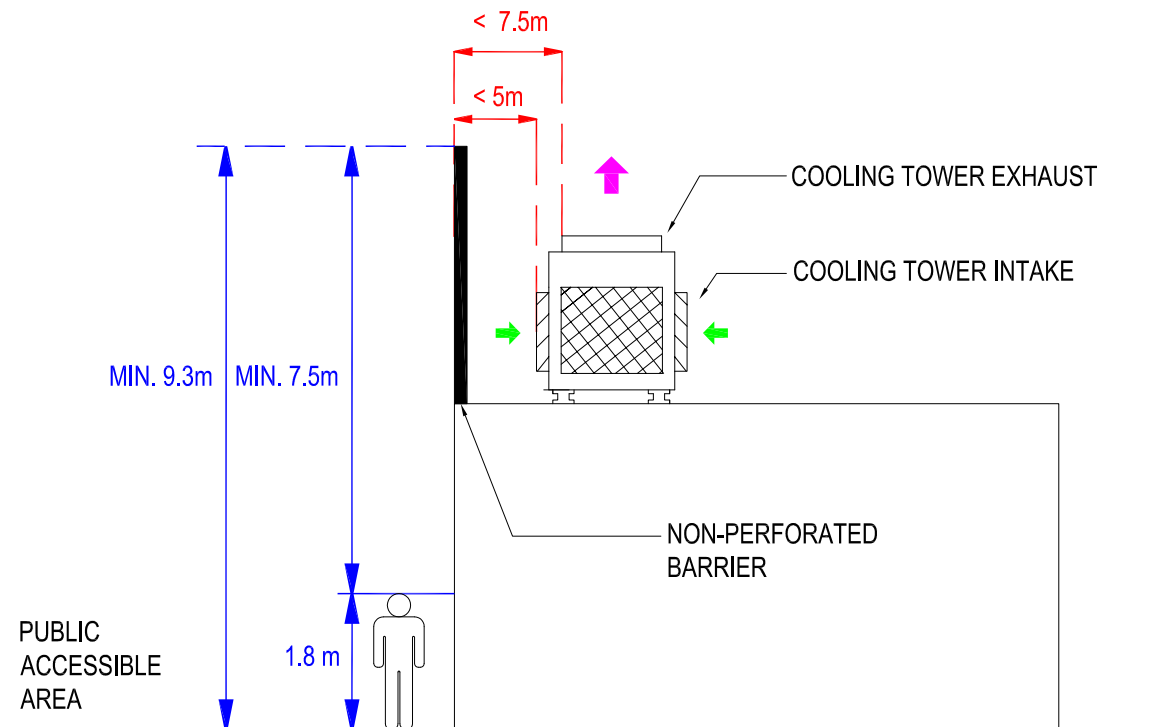

Figure B7 – Provision of non-perforated barrier

B3.2 – Cooling Tower installed at enclosed plant room

(refer to Section 4.1.7)

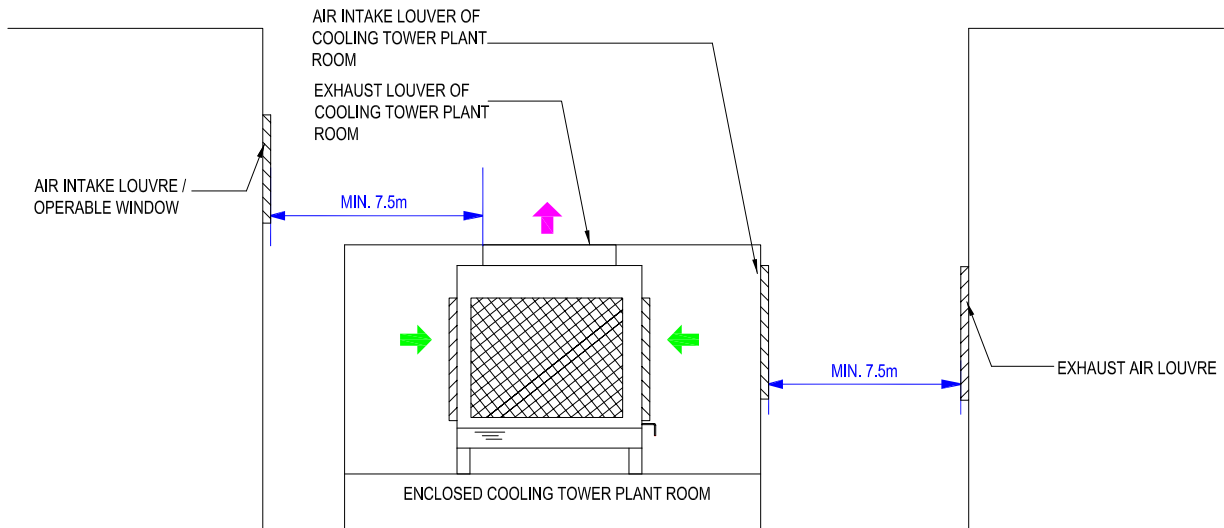

Figure B8 – Cooling tower at enclosed plant room

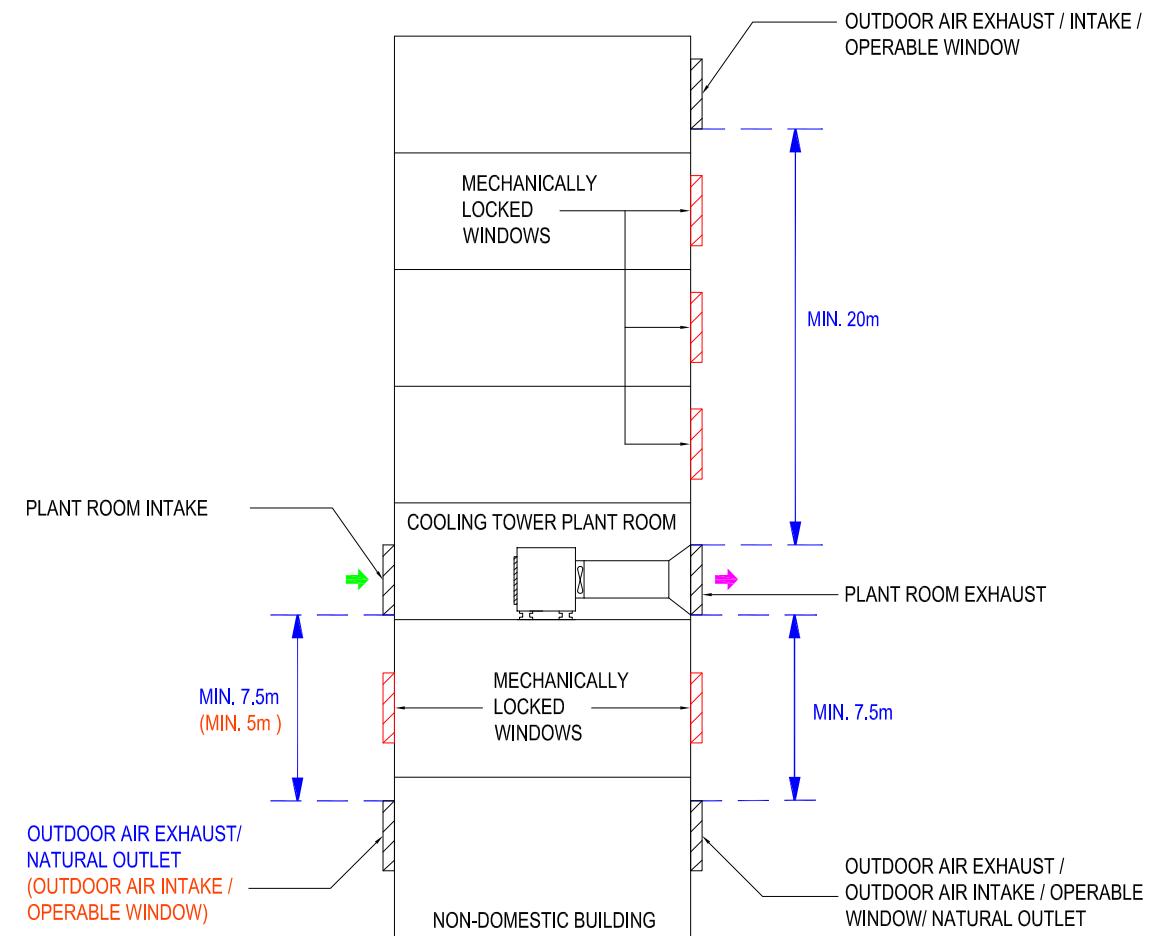
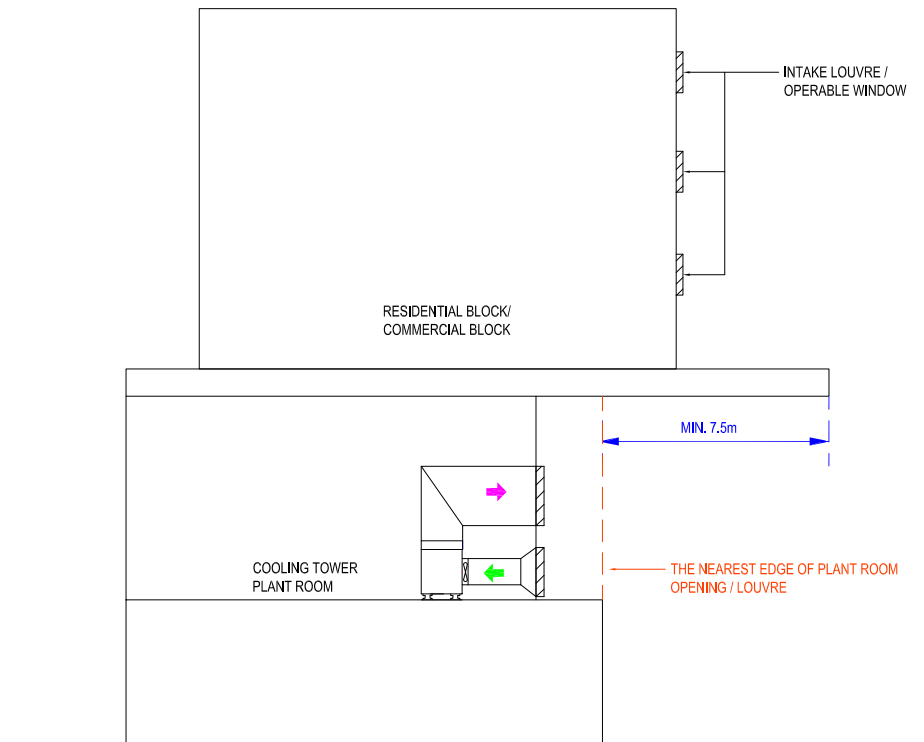

Figure B9 - Cooling tower at enclosed plant room

B3.3 – Cooling towers below extended podium

(refer to Section 4.1.8)



CASE (i)

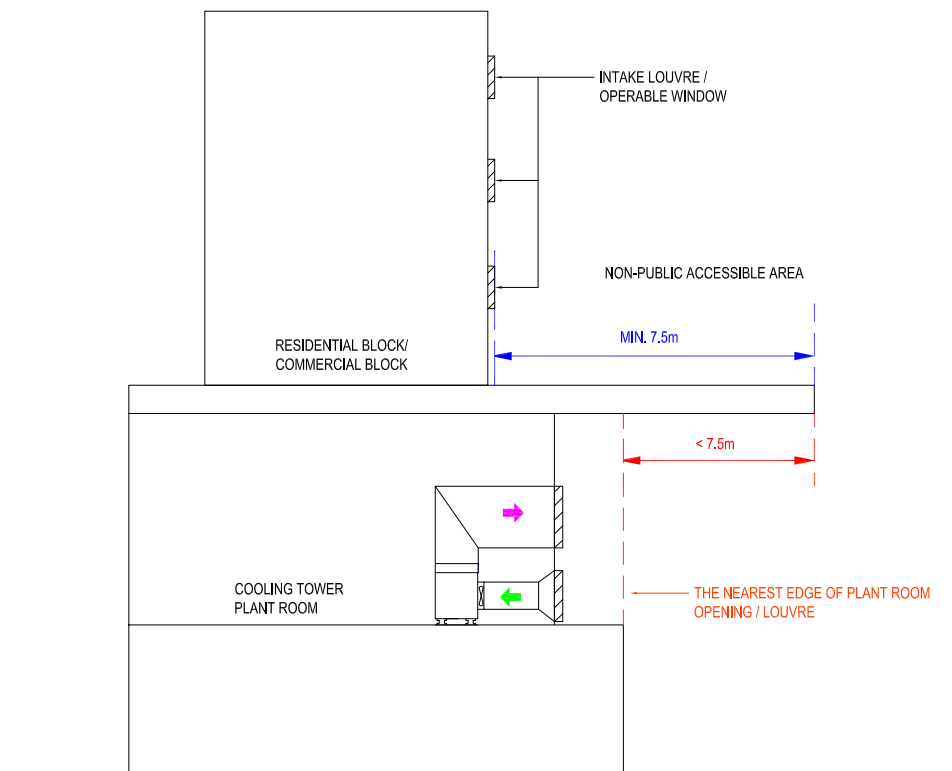

CASE (ii)

Figure B10 – Cooling towers below extended podium

Appendix 1C

Samples of Notices and Labels for Cooling Tower System

(i) Cooling Tower Registration No.:

機電工程署登記號碼	PS-2016-000-001 No. 1
EMSD Reg. No.	

Text height min.
50mm

(ii) Window located in cooling tower restricted area:

此窗戶位於冷卻塔限制範圍內，除緊急情況外，須保持關閉。
This window is located in cooling tower restricted area. It should be closed except emergency.

(iii) Passage located in cooling tower restricted area:

此通道位於冷卻塔限制範圍內，除緊急情況外，請勿進入。
This passage located in cooling tower restricted area. No entry except emergency.

(iv) Cooling water sampling point:

冷卻水取水樣本點(須每月取樣檢測)
Cooling water sampling point(Water sampling for testing monthly)

(v) Bleed-off water sampling point:

泄放水取水樣本點(須每三個月取樣檢測)
Bleed-off water sampling point (Water sampling for testing every 3 months)

(vi) Stagnant water purging valve:

死水排放閥門
(須每星期排放最少 15 分鐘)
Stagnant water purging valve
(Purge at least 15 minutes weekly)

Appendix 1D

A Standard Risk Management Plan for Fresh Water Cooling Tower System

A. System Description

Record	Details
Building Name and Building Address	
Cooling tower type	
Number of cooling tower in system	
Heat rejection capacities of the cooling towers	
Building owner's name/contact details*	
Owner of cooling tower 's name and contact details*	
Designer of cooling tower system 's name and contact details*	

* To include company name, contact person's business and after office hours telephone numbers

B. Major Risks – Location and Access

Types of Risk	Assessment	Mitigation Measures
Cooling tower system is located in/near an acute health or aged residential care facility		
Cooling tower exhaust creates nuisances to the public		
Cooling tower exhaust affects the intake and/or exhaust of nearby ventilation system		
Nearby air exhaust to supply nutrients for bacteria growth in cooling tower system (kitchen, toilet and carpark exhausts)		
Cooling tower next to public accessible area (including public green roof)		
Potential danger to maintenance workers		

C. Major Risks – Deficiencies in cooling tower system

Types of Risk	Assessment	Mitigation Measures
Drift emission from cooling tower		
Materials used support micro-organisms proliferation		
Failure of cooling tower system structure		

D. Major Risks – Stagnant Water

Types of Risk	Assessment	Mitigation Measures
Dead legs exist in water pipework		
Cooling tower(s) and associated pipework not in use for more than a month		

E. Major Risks – Nutrient Growth

Types of Risk	Assessment	Mitigation Measures
Contamination from surrounding area(s) (an increase of nutrients for bacteria growth in cooling tower system)		
Cooling tower’s wetted surfaces expose to direct sunlight (enhancing algae growth)		
Corrosion of system components		

F. Major Risks – Poor Water Quality

Types of Risk	Assessment	Mitigation Measures
HCC count		
Legionella Count		
Bleed-off water quality		
Malfunctioned chemical dosing system		

G. Other Risks

Types of Risk	Assessment	Mitigation Measures

H. Attachments

- Operation programme based on the above risk assessment result.
- Communication plan in case the cooling tower system is required to be attended urgently, such as positive legionella testing results, complaints from the public, etc.
- Procedure for monitoring and reviewing the Risk Management Plan.

Appendix 1E

A Sample Checklist for Minimum Testing and Commissioning Procedures of Fresh Water Cooling Tower System

Building Name	:	
Cooling Tower Designation	:	
Cooling Tower Type	:	
Manufacturer/Model No.	:	
Location	:	

A. Physical Check

	Items	Accepted	Not Accepted
1.	General Condition of Cooling Tower		
2.	Cleanliness of basin		
3.	Fixing of Drift Eliminator		
4.	Fixing of Fill		
5.	Fans Rotation without Obstruction		
6.	Fan & Pump Motor for Proper Rotation		
7.	Noise/Vibration		
8.	Drive Alignment/Belt Tension		
9.	Other Components, Bolts, Fixing, etc.		
10.	Bearings Lubrication		
11.	Drainage & Fall		
12.	Strainer Cleanliness		
13.	Ball Float Valve Function		
14.	Tower Water Level		
15.	Water Distribution		
16.	Water Treatment Equipment		
17.	Electrical Supply Connection		
18.	Earth Bonding		

B. Cooling Tower Thermal Performance Check

	Parameters	Unit	Design Data	Test Results
1.	Heat Rejection Capacity	kW		
2.	Air Flowrate	m ³ /s		
3.	Entering Air Dry Bulb Temperature	°C		
4.	Entering Air Wet Bulb Temperature	°C		
5.	Leaving Air Dry Bulb Temperature	°C		
6.	Leaving Air Wet Bulb Temperature	°C		
7.	Cooling Water Flow Rate	L/s		
8.	Cooling Water Entering Temperature	°C		
9.	Cooling Water Leaving Temperature	°C		
10.	Make-up Water Quantity	L/s		
11.	Constant Bleed Water Quantity	L/s		

C. Cooling Tower Fan Check

	Parameters	Unit	Design Data	Test Results
1.	Fan Type	-		
2.	Fan Diameter	m		
3.	Fan Volume	m ³ /s		
4.	Fan Power	kW		
5.	Fan Pressure	Pa		

D. Cooling Tower Electrical Test

	Parameters	Unit	Design Data	Test Results
1.	Supply Voltage	V		
2.	Motor Starting Current	A		
3.	Motor Running Current	A		
4.	Motor/Fan Speed	rpm		
5.	Phase – Phase Motor Insulation (RY/YB/BR)	MΩ		
6.	Phase – Earth Motor Insulation (RY/YB/BR)	MΩ		
7.	Motor Starter Type	-		

Appendix 1F

A Recommended List of Personal Protective Equipment

Job	Potential Hazard	Respirator and Clothing
Testing and commissioning	Aerosol	Half face piece, capable of filtering smaller than 5µm particulates, ordinary work clothing
Inspection	Aerosol	Half face piece, capable of filtering smaller than 5µm particulates, ordinary work clothing
Water Sampling	Aerosol	Half face piece, capable of filtering smaller than 5µm particulates, ordinary work clothing
High pressure spraying	Aerosol	Respirator as above, waterproof overalls, gloves, boots, goggles or face shield
Chemical treatment with sodium hypo-chlorite solution in ventilated space	Spray mist and very low concentration chlorine	Half face piece, acid gas and particulate respirator, goggles or face shield, overalls, gloves, and boots
As above, in confined space	Unknown chlorine concentration, high mist, possible lack of oxygen	To comply with the requirement under the Factories and Industrial Undertakings (Confined Spaces) Regulation

Energy Efficiency  **EMSD**

機電工程署 能源效益事務處

香港九龍灣啟成街三號

Energy Efficiency Office

Electrical and Mechanical Services Department

3 Kai Shing Street, Kowloon Bay, Hong Kong

電話 Tel: (852) 3912 0642

傳真 Fax: (852) 2890 6081

網址 Website: <https://www.emsd.gov.hk>

電郵 Email: info@emsd.gov.hk