The Hong Kong Voluntary Energy Efficiency Labelling Scheme for

Electronic Ballasts January 2022

Energy Efficiency  **EMSD**

Electrical and Mechanical Services Department
3 Kai Shing Street, Kowloon, Hong Kong
Homepage: <http://www.emsd.gov.hk>

Contents

| | | |
|-----|---|----|
| 1. | Purpose | 1 |
| 2. | Background | 1 |
| 3. | Scope | 2 |
| 4. | Definitions | 2 |
| 5. | Test Methodology and Technical Standard | 4 |
| 6. | Energy Efficiency and Performance Requirements | 6 |
| 7. | Energy Label | 10 |
| 8. | Testing Facilities, Laboratories & Accreditation Bodies | 11 |
| 9. | Registration and participation | 13 |
| 10. | Legal Provisions | 16 |
| 11. | Compliance, Monitoring and Inspection | 17 |
| 12. | Complaints Appeal | 19 |
| 13. | Maintenance of Scheme | 19 |
| 14. | Future Development | 20 |

Tables

| | | |
|----|---|---|
| 1. | Categories of Electronic Ballasts | 7 |
| 2. | Maximum allowable ballast-lamp circuit power for different lamp types | 8 |

Figures

| | | |
|----|--------------------------------|---|
| 1. | The Ballast-Lamp Circuit | 5 |
|----|--------------------------------|---|

Annexes

| | |
|---|---|
| 1 | The Hong Kong Voluntary Energy Efficiency Labelling Scheme for Electronic Ballasts – Energy Label Format |
| 2 | Proforma Letter of Invitation |
| 3 | Proforma Letter of Application |
| 4 | Information to be submitted to Energy Efficiency Office |
| 5 | Proforma Letter of Acceptance |
| 6 | Proforma Letter of Rejection |
| 7 | The Hong Kong Voluntary Energy Efficiency Labelling Scheme for Electronic Ballasts – Flow Chart of Registration |

1. Purpose

- 1.1 This set of document is intended to give a general description to the Hong Kong Voluntary Energy Efficiency Labelling Scheme for Electronic Ballasts (The Scheme).

2. Background

- 2.1 The Energy Efficiency Labelling Scheme (EELS) is an energy conservation initiative that the Government of the Hong Kong Special Administrative Region (HKSAR) has adopted. Under the EELS, some common types of household appliances/ gas appliances and office equipment will incorporate an energy label that serves to inform consumers of the product's energy consumption and efficiency. Consumers should then be able to take those factors into account in making their purchasing decision.
- 2.2 The concept of EELS has been implemented in several forms and in different stages of development in many countries. The EELS generally aims to achieve:
- greater public awareness of energy conservation and environmental improvement needs;
 - provision of readily available, pre-purchase information on energy consumption and efficiency data to enable ordinary consumers to select more energy efficient products;
 - stimulation to the manufactures/market for phasing out less energy efficient models; and
 - motivation of the actual energy savings behaviours and environmental improvements.
- 2.3 Hong Kong aims at achieving the above objectives. At present, the Hong Kong Voluntary Energy Efficiency Labelling Scheme covers 22 types of household appliances/ gas appliances and office equipment. Amongst them, 13 types are household appliances, 7 types are office equipment and 2 types are gas appliances.

3. Scope

- 3.1 The Scheme will only apply to the manufacturers and importers (i.e. local agents, retailers and the related parties) of electronic ballasts who are interested to or have participated in the Scheme.
- 3.2 The Scheme commenced on 23 December 2004. It is further revised on 1 January 2022. The existing and newly registered labels will remain valid till 31 December 2024. By then, renew of the application may be required subject to the review of the Scheme.
- 3.3 Unless the Director provides otherwise, the Scheme applies to electronic ballasts that are –
- a. designed for standard fluorescent lamps (for linear, circular and compact types). The electronic ballasts must be capable of being powered from either a 220V 50Hz AC supply or an appropriate DC power source.
 - b. with dimmable facility which are measured and tested at their full output conditions.
- 3.4 The scope of the Scheme covers all new electronic ballasts which are to be sold, imported to or manufactured in Hong Kong with effect from the date that is declared by the participant but does not cover second-hand products, products already in use, under trans-shipment or manufactured for export, etc.
- 3.5 The Scheme is operated as a ‘Recognition Type’ labelling system. All participating electronic ballasts will be recognised and registered under this Scheme provided that they have met the energy efficiency and performance requirements as stipulated in the Scheme.

4. Definitions

Unless otherwise specified, the following definitions shall apply throughout this document:

Authority means the Electrical & Mechanical Services Department (EMSD), the Government of the HKSAR.

| | |
|----------------------|--|
| ballast lumen factor | means a ratio of the light output of the lamp when the electronic ballast under test is operated at its rated voltage compared with the light output of the same lamp operated with the appropriate reference electronic ballast supplied at its rated voltage and rated frequency. |
| circuit power factor | means the power factor of the combination of an electronic ballast and the lamp or lamps for which the electronic ballast is designed. |
| Director | means the Director of Electrical & Mechanical Services Department. |
| electronic ballast | means a ballast involving high frequency switching that is controlled by active components (transistors, thyristors, and the high frequency oscillator), and with the lamp ballasting impedance provided by a series capacitive or inductive reactance appropriate for the high switching frequency. |
| Government | means the Government of the HKSAR. |
| IEC | means International Electrotechnical Commission. |
| inspecting officer | means the officer authorized by the Director to carry out inspection on electronic ballasts. |
| ISO | means the International Organization for Standardization |
| label | means the energy label as described in Section 7 of this document. |
| lamp | means the fluorescent lamp in this document |
| mains electricity | means the electricity that is supplied in Hong Kong at a voltage of 380/220V with a frequency of 50 Hz |
| participant | means the manufacturers, importers or the retailers of electronic ballasts who are participating in the Scheme. |
| rated frequency | means the frequency marked on the nameplate or declared as such by the participants for the electronic ballasts. |
| rated voltage | means the voltage marked on the nameplate or declared as such by the participants for the electronic ballasts. |

| | |
|------------------------------|---|
| rated wattage | means the wattage marked on the nameplate or declared as such by the participants for the electronic ballasts. |
| recognised laboratory | means a laboratory that complies with the requirements as stated in Section 8 of this document and is acceptable to the Authority for carrying out tests and issuing test reports on electronic ballasts. |
| reference electronic ballast | means the special electronic ballast designed for the purpose of providing comparison standards for testing electronic ballasts and for selecting reference lamps. It is essentially characterized by the fact that at its rated frequency it has a stable voltage/current ratio which is relatively uninfluenced by variations in current, temperature and magnetic surroundings |
| reference lamp | means fluorescent lamp selected for testing electronic ballasts which, when associated with a reference electronic ballast under specified conditions, has electrical characteristics which are close to the nominal values as stated in the relevant fluorescent lamp standard for that particular type of fluorescent lamp |
| the/this Scheme | means the Hong Kong Voluntary Energy Efficiency Labelling Scheme for Electronic Ballasts. |
| total circuit power | means a total power dissipated by electronic ballast and lamp in combination, at rated voltage and rated frequency of the electronic ballast. |

5. Test Methodology and Technical Standard

General

- 5.1 All test methods, standards and specifications specified in this document are only related to checking compliance with the energy efficiency and general performance requirements of the electronic ballasts. It is not the intention of this document to detail out the test standards and requirements for checking compliance with the Electrical Products (Safety) Regulation of the HKSAR. The participant should conduct appropriate tests, where necessary, in addition to those specified in this document in order to obtain Certificates of Safety Compliance for his electronic ballasts.

Test Standards - Safety Requirements

- 5.2 The testing standard for checking compliance with the safety requirements of the electronic ballasts are based on the international standard IEC 61347-2-3, Lamp control gear – Part 2-3: Particular requirements for a.c. supplied electronic ballasts for fluorescent lamps (hereinafter named as “lamps”), or its equivalent. For detailed requirements and procedural descriptions one should refer to the respective standards.
- 5.3 To the extent that definitions in the IEC standards do not conflict with the definitions of this document, the definitions in the aforesaid standards shall be included.

Test Conditions

- 5.4 For all electronic ballasts, the test conditions shall be as follows –
- | | |
|---|--|
| (a) Electrical supply | $220V \pm 1\%$; |
| (b) Frequency | $50\text{Hz} \pm 0.5\%$; |
| (c) Ambient temperature | $25^{\circ}\text{C} \pm 5^{\circ}\text{C}$; |
| (d) Total Harmonic Distortion (voltage) | $< 2\%$ THD. |

Testing Methodology

- 5.5 The measuring method for the total input power of the ballast-lamp system shall make reference to the European Standard EN 50294. In accordance with EN50294, the measurement of the total input power should be set up as follows:

Figure 1 : The ballast-lamp circuit

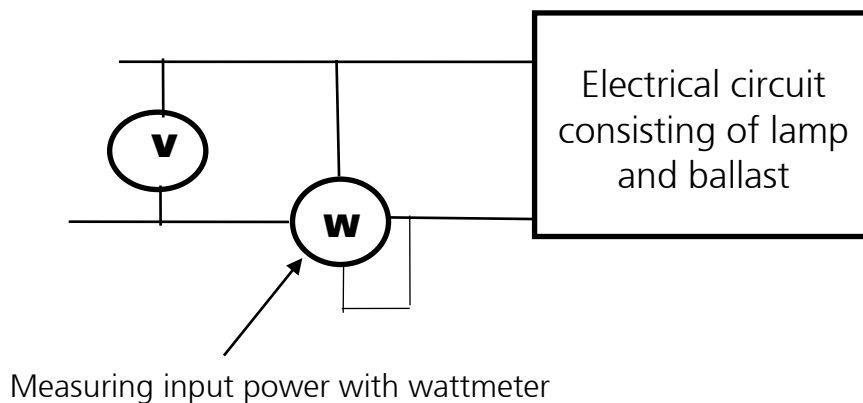

- 5.6 The testing method is primarily aimed at measuring the total input power for the ballast-lamp circuit (Figure 1) under tested. The tested electronic ballast shall be operated with an appropriate reference lamp and the total input power, and lumen output are compared to the reference circuit using reference electronic ballast and the same reference lamp. If measurement of lumen output is not feasible, the measurement of fluorescent lamp power is also acceptable for comparison purposes.
- 5.7 The total circuit power and lamp lumen output (or lamp input power) is normalized back to standardized levels for comparison purposes. This standard was specifically developed by CELMA (Federation of National Manufacturers Associations for Luminaires and Electrotechnical Components for Luminaires in the European Union) and use for the test method to determine the electronic ballast energy efficiency. The scope of the standard covers double and single capped fluorescent lamps and their electronic ballasts. The standard mandates that an electronic ballast lumen factor be declared by the manufacturer has to be in the range between 0.925 and 1.075 for electronic ballasts.
- 5.8 The corrected total circuit power and the lamp lumen output (or lamp input power) are measured for both tested and reference circuits. The total input power for the tested ballast-lamp circuit is corrected by the ratio of the lumen output for the reference circuit to the lumen output of the tested circuit. Alternatively, the total power could also be corrected by the ratio of the nominal lamp power (lamp data sheet) for the reference circuit to the measured lamp power of the test circuit.

6. Energy Efficiency and Performance Requirements

Energy Efficiency Specifications for Qualifying Products

- 6.1 Any electronic ballasts that are marketed to the consumer as such and meet the definition in clause 3.3 are eligible for the application of EELS for electronic ballasts.
- 6.2 Only for those products that meet the following criteria may qualify to obtain the energy label.

Performance Requirements

- 6.3 All electronic ballasts shall comply with IEC 60929 – 2003, AC-supplied electronic ballasts for tubular fluorescent lamps - Performance requirements, or its equivalent.

Methods for Calculating the Maximum Allowable Power Consumption

- 6.4 The energy efficiency of the ballast-lamp circuit is determined by the total input power into the circuit. This is a function of the lamp power and of the type of electronic ballast; for this reason, as shown in Table 2, the maximum allowable power consumption of a given ballast is defined as the maximum ballast-lamp circuit power, for each lamp power and electronic ballast type.
- 6.5 To calculate the maximum allowable consumption of a given electronic ballast, it must therefore first be allocated to the appropriate category for the lamps in Table 1.

Table 1 : Categories of Electronic Ballasts

| Category | Description |
|----------|--|
| <u>1</u> | Electronic Ballast for linear fluorescent lamp type (e.g. T8 & T5 lamps) |
| <u>2</u> | Electronic Ballast for compact 2 tubes fluorescent lamp type |
| <u>3</u> | Electronic Ballast for compact 4 tubes flat fluorescent lamp type |
| <u>4</u> | Electronic Ballast for compact 4 tubes fluorescent lamp type |
| <u>5</u> | Electronic Ballast for compact 6 tubes fluorescent lamp type |
| <u>6</u> | Electronic Ballast for compact 2 D fluorescent lamp type |
| <u>7</u> | Electronic Ballast for circular fluorescent lamp type |

- 6.6 Under these category arrangements in Table 1, the maximum allowable ballast-lamp circuit power consumption expressed in watt for those common lamp types is defined in Table 2 below. Whenever a lamp power of electronic ballast falls between two values indicated in the below table, the maximum input power of ballast-lamp circuit should be calculated by linear interpolation between the two values of maximum input power for the two closest lamps power indicated in the table.

Table 2 : Maximum allowable ballast-lamp circuit power for different lamp types

| Electronic Ballasts | | Rated Lamp Power | | Maximum Allowable Power Consumption |
|---------------------|------------------------------|------------------|---------------------------------------|-------------------------------------|
| Category | Description | 50 Hz | High Frequency (HF) | |
| 1 | for linear fluorescent lamps | 4 W | 3.4 W | ≤ 6 W |
| | | 6 W | 5.1 W | ≤ 8 W |
| | | 8 W | 6.7 W | ≤ 11 W |
| | | 13 W | 11.8 W | ≤ 15 W |
| | | 15 W | 13.5 W | ≤ 16 W |
| | | 18 W | 16 W | ≤ 19 W |
| | | 30 W | 24 W | ≤ 31 W |
| | | 36 W | 32 W | ≤ 36 W |
| | | 38 W | 32 W | ≤ 38 W |
| | | 58 W | 50 W | ≤ 55 W |
| | | 70 W | 60 W | ≤ 68 W |
| | | -- | 14 W | ≤ 17 W |
| | | -- | 21 W | ≤ 24 W |
| | | -- | 24 W | ≤ 27 W |
| | | -- | 28 W | ≤ 32 W |
| | | -- | 35 W | ≤ 39 W |
| | | 2. | for compact 2 tubes fluorescent lamps | 5 W |
| 7 W | 6.5 W | | | ≤ 9 W |
| 9 W | 8 W | | | ≤ 11 W |
| 11 W | 10 W | | | ≤ 14 W |
| 13 W | 12 W | | | ≤ 16 W |
| 18 W | 16 W | | | ≤ 19 W |
| 24 W | 22 W | | | ≤ 25 W |
| 36 W | 32 W | | | ≤ 36 W |
| -- | 40 W | | | ≤ 45 W |
| -- | 55 W | | | ≤ 61 W |

| Electronic Ballasts | | Rated Lamp Power | | Maximum Allowable Power Consumption |
|---------------------|--|--|--|--|
| Category | Description | 50 Hz | High Frequency (HF) | |
| 3. | for compact 4 tubes flat fluorescent lamps | 18 W 24 W 36 W | 16 W 22 W 32 W | ≤ 19 W ≤ 25 W ≤ 36 W |
| 4 | for compact 4 tubes fluorescent lamps | 10 W 13 W 18 W 26 W | 9.5 W 12.5 W 16.5 W 24 W | ≤ 11 W ≤ 14 W ≤ 19 W ≤ 27 W |
| 5 | for compact 6 tubes fluorescent lamps | 18 W 26 W -- -- | 16.5 W 24 W 32 W 42 W | ≤ 19 W ≤ 27 W ≤ 36 W ≤ 47 W |
| 6 | for compact 2 D fluorescent lamps | 10 W 16 W 21 W 28 W 38 W -- | 9 W 14 W 19 W 25 W 34 W 55 W | ≤ 11 W ≤ 17 W ≤ 22 W ≤ 29 W ≤ 38 W ≤ 61 W |
| 7 | for circular fluorescent lamps | 22 W 32 W 40 W -- -- -- | 19 W 30 W 32 W 22 W 40 W 55 W | ≤ 22 W ≤ 35 W ≤ 37 W ≤ 26 W ≤ 45 W ≤ 61 W |

- 6.7 In accordance with the information shown in Table 2, the electronic ballast takes advantage of the unique feature of a fluorescent lamp whereby greater efficacy is obtained at high operating frequency. The overall lighting system efficacy can be increased by 20 to 30 percents due to the improvement of lamp efficacy at high frequency operation and the reduction of circuit power losses. The efficacy at high frequency operation is increased by about 10%, thereby enabling the lamp to be operated at a lower input power than at 50 Hz mains power frequency. Taking an example for a 36W lamp (Category 1), it normally consumes more than 45W total circuit power. But when applying with electronic ballasts, only 36W is consumed for the same light output. The net effect proves that in a typical luminaire, the same amount of useful light output is maintained at a comparatively lower input of power.

Other Technical Requirements

- 6.8 The operating frequency for all electronic ballasts should be above 20 kHz to be above the human audibility. In addition, taking into consideration that the frequency range from 30 to 40 kHz is more or less reserved for IR systems, the operating frequency for all electronic ballasts should be designed to avoid the said range.

Safety Requirements

- 6.9 All materials and workmanship of the electronic ballasts are also needed to comply with the safety requirements are based on IEC 61347-2-3, Lamp control gear - Part 2-3: Particular requirements for a.c. supplied electronic ballasts for fluorescent lamps, or its equivalent and/or the Electrical Products (Safety) Regulation of the HKSAR, where applicable.

7. Energy Label

- 7.1 The specification of the energy label for electronic ballast is shown in Annex 1. After a reference number has been assigned to a product model in the name of a specified person and included in the Director's record, the specified person shall produce the energy label for his/her products of the listed model showing the information in strict accordance with the requirements in Annex 1.

- 7.2 (a) Subject to clause 7.2(c), the energy label is to be attached or affixed to a prominent position of the electronic ballast and is to be clearly visible. The participant should ensure that the label appears on every registered electronic ballast on display, sale or hire.
- (b) For the avoidance of doubt, if only part of the electronic ballast is being exhibited, the energy label is to be attached or affixed to a prominent position of that part and is to be clearly visible.
- (c) The energy label may be attached to the electronic ballast or its packaging in a manner specified by the Director where the Director has approved its being so attached.
- 7.3 The energy label shall be of cardboard, if it is to be attached as a swing tag, or be self-adhesive and shall be cut to the outline shown in Annex 1 or otherwise approved by the Director. A trim or die cut margin of up to 2 mm around the energy label is acceptable.
- 7.4 The paper used for the energy label shall be durable with good wear and tear characteristics.
- 7.5 The energy label should be printed in both Chinese and English. Soft copy of the energy label can be obtained from Energy Efficiency Office, Electrical and Mechanical Services Department.

8. Testing Facilities, Laboratories & Accreditation Bodies

- 8.1 The testing shall be carried out either by independent test institutes or by the manufacturers or by the importers themselves at their own test facilities. The Authority will accept the results and certificates issued by the test laboratory, which fulfils one of the following criteria as specified in clauses 8.2, 8.3 or 8.4.
- 8.2 The laboratory is accredited by the Hong Kong Accreditation Service (HKAS) for the relevant test under the Hong Kong Laboratory Accreditation Scheme (HOKLAS) or a scheme with which HOKLAS has concluded a mutual recognition agreement (MRA) #, and the results are issued in a test report or certificate bearing the accreditation mark.

HKAS has concluded mutual recognition arrangements with overseas accreditation bodies for testing laboratory accreditation. The list of mutual recognition arrangement partners may change from time to time and the up-to-date list is available from the HKAS website of www.info.gov.hk/itc/hkas. Partners to these arrangements recognise the accreditations granted by one another as equivalent.

- 8.3 The Authority will also consider the following –
- (a) Self-certification by original manufacturers that the operations of their in-house laboratories satisfy the requirements of ISO/IEC 17025; and
 - (b) The manufacturers are currently operating according to a recognised international quality system (such as ISO 9001); and
 - (c) The manufacturer’s in-house laboratories had successful in carrying out tests on electronic ballasts and where these tests had been evaluated and certified by third party internationally independent recognised certification organisations.

Laboratory Accreditation

- 8.4 The Authority takes cognizance of the need to ensure acceptable and compatible quality standards of testing laboratories, and considers that they need to be accredited by some independent bodies.
- 8.5 The criteria of accreditation should be based on ISO/IEC 17025 and accreditation bodies should operate in accordance with ISO/IEC 17011.
- 8.6 The Authority will recognise accreditation granted by the HKAS under the Hong Kong HOKLAS and by overseas accreditation bodies which have concluded mutual recognition arrangements with HKAS for accreditation of testing laboratories. The Authority will consider accreditation by other bodies on a case-by-case basis.

Energy Efficiency Verification Service

- 8.7 An increasing number of countries now accept, as proof of product conformance, energy efficiency verification services provided by third-party organisation that has been accredited as a certification organisation. In accordance with this trend, the Authority will consider seriously test results that have been evaluated and verified against the energy performance standards of the Scheme by reputable third-party certification organisations.

9. Registration and participation

Registration Procedures

9.1 All manufacturers, importers and the other parties involved in the electronic ballasts business are welcome and encouraged to participate in the Scheme. The Authority will send invitation to those known manufacturers and importers. However, no matter whether invited or not, any interested parties may submit their applications for the registration.

9.2 The proforma letter of invitation is shown in Annex 2.

9.3 Applicant should submit formal application to

*Chief Engineer/Energy Efficiency A
Energy Efficiency Office
Electrical and Mechanical Services Department
3 Kai Shing Street, Kowloon
Hong Kong*

by means of an application letter through mail, facsimile or electronic mail. In order to ensure effective implementation of the Scheme, the applicant must commit himself to fully comply with the duties, responsibilities and obligations set out in the Scheme. The proforma letter of application as shown in Annex 3 details the aforesaid obligations and should be used for application. To facilitate the application process, the application form can be downloaded from EMSD website.

Information/Documents to be Submitted for Registration

9.4 Each make and model of an electronic ballast product participating in the Scheme should be provided with a test report issued by a recognised laboratory. The test report should contain energy efficiency test and performance test results.

9.5 The details of the technical information to be submitted together with the application are listed as follows: -

- a) Information on the company
Name, Address, Telephone number, Fax number, E-mail address, Contact person, Importer, Distributor, etc.
- b) Product to apply for participating in the Scheme:

- Name of products, types, brand names, models, countries of origin, etc.
- c) The party that will be responsible for making and fixing the Energy Label;
- d) Commencement date to affix energy label on electronic ballast packaging
Year _____, Month _____
- e) Detailed test reports shall provide at least the following relevant technical data for the participating electronic ballasts:
- Testing conditions (i.e. ambient temperature, supply voltage and frequency);
 - Lamp lumen output/ lamp power for the reference circuit and the test circuit;
 - Reference ballast power and test ballast power loss;
 - Corrected total circuit power for the reference circuit and test circuit;
 - Operative frequency;
 - Power rating at HF operation; and
 - Comparison between measurement of lamp power and maximum allowable power consumption.
- f) Miscellaneous Technical Information:
- Product information catalogue
 - Technical Specification
 - Others
- g) Documentary proof that the participating electronic ballast(s) comply with IEC 61347-2-3, Lamp control gear - Part 2-3: Particular requirements for a.c. supplied electronic ballasts for fluorescent lamps, and/or the Certificate of Safety Compliance prescribed by the “Electrical Products (Safety) Regulation of the Hong Kong Special Administrative Region” (Chapter 406G).

The above list of information can also be found in Annex 4, Information to be submitted to Energy Efficiency Office.

- 9.6 Company's name and chop should be stamped on all the documents provided. All photocopy test reports submitted to the Authority shall be certified true copy by appropriate organization.

Acceptance of Registration

- 9.7 On receipt of the application, the Authority will process the application and verify whether the electronic ballast meets the energy efficiency and performance requirements based on the submitted data. The accuracy of the submitted data, their inconsistencies and non-compliance will be dealt with in accordance with clause 11.2.
- 9.8 If the application is accepted, the participants will be notified of the result in writing within 17 working days upon receipt of all necessary information requested. The participants will then be allowed to affix the energy label onto the 'registered' electronic ballasts packaging. Both manufacturer and importer of the registered electronic ballasts should ensure that the energy labels are correctly printed and affixed on the electronic ballasts packaging in accordance with section 7. The proforma letter of acceptance is shown in Annex 5.
- 9.9 If the application is rejected, the notification letter (proforma letter of rejection as shown in Annex 6) will also be given within 17 working days upon receipt of all necessary information requested.
- 9.10 The flow chart for registration is shown in Annex 7

Participant's Duties, Responsibilities and Obligations

- 9.11 The participant is obliged to:-
- a) submit application and information including test results in accordance with format & procedures set out in clauses 9.3 to 9.6;
 - b) conduct tests via recognised laboratories and to comply with the specified test methodology and classification;
 - c) produce and affix energy labels at his own costs;
 - d) fully inform other sales agents in his distribution network once the particular make and model of an electronic ballast is registered under the Scheme;
 - e) allow random/ad-hoc inspection to be conducted by persons authorized by the Authority on registered electronic ballasts at his premises;
 - f) conduct re-test(s) at his own costs at some recognised laboratories, if non-compliance is found on the electronic ballast. The result of re-test(s) shall reach the Authority within the prescribed period of time specified by the Authority;

- g) inform the Authority of any change in the technical information and data that were previously submitted to the Authority together with the application letter;
- h) accept the fact that if the registered electronic ballast fails to perform in accordance with the required standard performance as given in Section 6 and this cannot be readily rectified, the Authority may order it be de-registered from the Scheme; and
- i) remove all labels from the de-registered electronic ballasts immediately.

9.12 The details of the registered electronic ballasts under the Scheme will be kept in a register list maintained by the Authority. The registration records will be regularly uploaded and maintained in the EMSD Internet for public and interested parties for browsing and reference.

Termination

- 9.13 Under circumstances of poor performance of the participant such as –
- (a) (repeated) failure to fulfil the obligations set out under clause 9.11; or
 - (b) false, inaccurate or misleading information is given on the energy label; or
 - (c) in any other case where the Director is of the opinion that registration of the particular electronic ballast is contrary to the public interest,

the Authority may de-register the concerned electronic ballast from the Scheme with immediate effect by giving the participant a notice in writing. Once the electronic ballast is de-registered, energy label is not allowed to fix on it.

The concerned electronic ballast could be de-registered even when there is no legal action taken under either the Trade Description Ordinance (Cap. 362) or the Copyright Ordinance (Cap. 528).

- 9.14 Participant who decides to discontinue participating in the Scheme or to withdraw any registered model from the registered electronic ballasts list shall give at least three months' advance notice to the Authority.

10. Legal Provisions

- 10.1 The Scheme is a voluntary scheme. However, a participant who abuses the Scheme by giving false information may contravene provisions of the Trade Description Ordinance (Cap. 362).

- 10.2 No one could take advantage of the scheme by using the energy label on his electronic ballasts without authorization of the Authority as that shall constitute an infringement of copyright under the Copyright Ordinance (Cap. 528).

11. Compliance, Monitoring and Inspection

Purpose

- 11.1 To uphold the credibility of the Scheme and to continue maintaining the confidence of the consumers, compliance check on energy labels on those electronic ballasts participating in the Scheme are needed. Also, to avoid the non-participating parties from taking advantage of the Scheme by using unauthorized labels, suitable form of inspection shall be conducted on those electronic ballasts which have not been registered under the Scheme.

Scope

- 11.2 The scope of inspection includes sample **checking** and **testing** of the following items:-
- (a) whether the energy label is affixed on the registered electronic ballast packaging;
 - (b) whether the energy label on the registered electronic ballast packaging is affixed to a prominent position in accordance with clause 7.2;
 - (c) whether the energy label being displayed is of correct format in accordance with section 7;
 - (d) whether the registered electronic ballast complies with the energy efficiency and the performance requirements;
 - (e) whether the data submitted by the participants are correct by random re-testing; and
 - (f) whether the unregistered electronic ballasts display unauthorized energy labels.
- 11.3 The participants will be requested to take immediate remedial action and report of follow-up action taken if non-compliance is found on their electronic ballasts.

- 11.4 For a registered electronic ballast carrying energy label but found not meeting the energy efficiency and performance requirements stipulated in section 6, the participant will be requested to repeat the performance tests specified in accordance with the test methodology and technical standards stipulated in section 5 by an accredited testing laboratory.
- 11.5 If non-compliance is confirmed and no remedial action is to be taken by the applicant, the Authority may order it be de-registered from the Scheme. Failure to remove energy labels from the de-registered electronic ballasts after the Director has withheld his authorization for using such labels may contravene the relevant ordinances.

Inspecting Officers

- 11.6 The Authority will authorize inspecting officers to carry out compliance monitoring and inspection on electronic ballasts. The officers will carry proper identification cards which will be produced upon request during their inspection operations. However, the officer will not inform the participants in advance of their intended inspection operation.
- 11.7 It is the participants' obligation to allow the inspecting officers to gain access to their premises to carry out inspection.

Mode of Inspection

- 11.8 Inspections will be carried out on registered electronic ballasts under the Scheme on random basis. Based on the record of the registration, random inspection programmes will be developed.
- 11.9 In addition to the random inspections, the inspecting officers will carry out ad-hoc inspections in response to complaints. The items to be inspected in such a case will depend upon the nature of complaint and may include all types of inspection as stated in clause 11.2.
- 11.10 Inspections will normally be carried at the electronic ballasts retail outlets and showrooms. Where necessary, inspection will also be done at warehouses.
- 11.11 The inspection results will be properly recorded for future analysis as well as on evaluation of the effectiveness of the Scheme.

12. Complaints Appeal

- 12.1 The Authority will be responsible for dealing with the complaints from participant and other parties against matters related to the Scheme.

Complaints Handling Procedures

- 12.2 The Director shall ensure that complaints are properly recorded and handled without undue delay.
- 12.3 The Authority shall carry out preliminary investigation on complaints and reply to the complainants within a reasonable time. For complaints that require site inspection and laboratory test, the complainant shall be notified through an interim reply.
- 12.4 The Authority shall inform the complainant of the results or decisions made on the complaint.

Appeal Procedures

- 12.5 A participant who feels aggrieved by the decision given or action taken by the Authority according to section 11 may appeal to the Director in writing stating the reason for the appeal.
- 12.6 The Director may decide to suspend the decision or action given by the Authority from the day on which the appeal is made until such appeal is disposed of, withdrawn or abandoned unless such suspension would, in the opinion of the Director, be contrary to public interest.
- 12.7 The Director may by notice to the appellant require that appellant to attend meeting with him or his representative, provide documents and give evidence relevant to the appeal.
- 12.8 The Director shall notify the appellant of his decision and the reasons for it. The decision will be final and binding.

13. Maintenance of Scheme

- 13.1 To ensure that the Scheme can continue to operate effectively and efficiently after its introduction, a proper system of maintenance is needed.

- 13.2 The maintenance system consists essentially of -
- (a) Continuous updating of the following relevant information of the participants in the Scheme-
 - i). Details of the registered electronic ballasts such as registration number, date of registration or de-registration if it occurs, energy efficiency data, performance data, make, model and other related information; and
 - ii). Details of the registered importers, manufacturers, local agents, etc.; in the distribution network such as address, date of registration or de-registration if it occurs, etc.
 - (b) Periodic review of the test methodology, and procedures for application of registration and compliance monitoring, etc., to bring them in line with the latest needs of the manufacturers, importers and retailers, etc.
 - (c) Continuous evaluation of the effectiveness of the Scheme and assessment of what changes are necessary.

14. Future Development

- 14.1 It is hoped that following the implementation of the Scheme, the market will phase out models of low efficiency products and public awareness of using energy efficient products will be much improved.
- 14.2 To further facilitate the public in choosing energy efficient appliances and raise public awareness on energy saving, the Government has introduced a mandatory Energy Efficiency Labelling Scheme through the Energy Efficiency (Labelling of Products) Ordinance.
- 14.3 Under the mandatory EELS, energy labels are required to be shown on prescribed products for supply in Hong Kong to inform consumers of their energy efficiency performance. Eight types of prescribed products covered in the mandatory EELS are room air conditioners, refrigerating appliances, compact fluorescent lamps, washing machines, dehumidifiers, televisions, storage type electric water heaters and induction cookers.

The Hong Kong Voluntary Energy Efficiency Labelling Scheme
for Electronic Ballasts
Energy Label Format

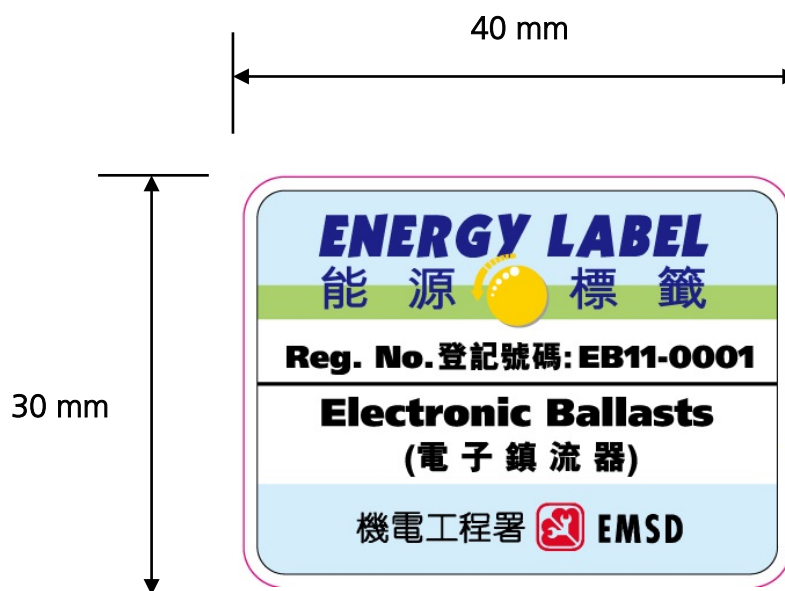

(Not to Scale)

Notes : The figure of the energy label is shown not to scale.

Soft copy of this label can be obtained from Energy Efficiency Office,
Electrical and Mechanical Services Department.

Proforma Letter of Invitation

Our ref. : () EMSD/EEO/LB/29

Your ref.

Tel.

Fax.

Date

[Name and Address of
Manufacturers/Importers/Agents]

Dear Sir/Madam,

Invitation of Application for Registration in The Hong Kong Voluntary Energy Efficiency Labelling Scheme for Electronic Ballasts

Having gone through the necessary consultations and duly considered the views from various concerned parties, the government has decided to introduce a voluntary energy efficiency labelling scheme for electronic ballasts to Hong Kong with effect from (_____). The details of the Scheme^① have been finalized and I enclose herewith a guide of the Scheme for your reference.

Being one of the major electronic ballasts' manufacturers / importers / agents^② in Hong Kong, you are invited to participate in the Scheme so as to take part in promoting public awareness in energy conservation and environmental improvement to Hong Kong. If you are interested to participate in the scheme, please apply in accordance with the proforma letter of application (Annex 3) and submit details including technical information in accordance with the attached Annex 4 to the 'Chief Engineer / Energy Efficiency A' at the following address.

Energy Efficiency Office
Electrical and Mechanical Services Department
3 Kai Shing Street, Kowloon
Hong Kong

Please be reminded to submit accurate test data to support your application. Under this Scheme, routine compliance monitoring and checking will be performed and if a registered electronic ballast is found to be non-compliant, we may consider deregistering the electronic ballasts from the Scheme.

Should you need further clarification or information, you are most welcome to contact the undersigned or Mr _____, at the telephone number _____.

Yours faithfully,

for Director of Electrical & Mechanical Services

(Note : ^① 'Scheme' means 'The Hong Kong Voluntary Energy Efficiency Labelling Scheme for Electronic Ballasts '

^② delete as appropriate)

Proforma Letter of Application

Your ref. : () EMSD/EEO/LB/29
Our ref.

Tel.

Date

Chief Engineer/Energy Efficiency A
Electrical & Mechanical Services Department
3 Kai Shing Street, Kowloon
Hong Kong

Dear Sir/Madam,

Application for Registration in The Hong Kong Voluntary Energy Efficiency Labelling Scheme for Electronic Ballasts

Our company is the (manufacturer/importer/agent*) of _____ in Hong Kong. We support the introduction the labelling scheme to Hong Kong and would like to be one of the participants in the Scheme to promote energy efficiency.

I understand fully the obligations and duties stated in the Scheme and will comply with all relevant requirements, in particular those specified below:

- i) conduct tests via recognised laboratories and to comply with the specified test standards;
- ii) produce and affix specified labels at my own costs;
- iii) allow random/ad-hoc inspection to be conducted by persons authorized by the issuing Authority on registered electronic ballast at my premises;
- iv) conduct re-test(s) at my own costs at some recognised laboratories, if the results of inspection suggest inaccurate energy label information being displayed. The result of re-test(s) shall reach the Authority within the prescribed period time specified by the Authority;
- v) inform the Authority of any change in the technical information and data that were previously submitted to the Authority together with the application letter; and
- vi) accept the fact that if electronic ballast fails to perform in accordance with the required energy efficiency standards and performance as given in Section 6 and this cannot be readily rectified, the Authority may order it be de-registered from the Scheme.

The details of information of those electronic ballasts which we intend to register with the Authority are shown in the attached document (Annex 4), and are submitted herewith for your vetting.

Yours faithfully,

(Manufacturer/Importer/Agent's Name and Company Chop)

* *delete as appropriate*

Information to be submitted to Energy Efficiency Office

1. Information on the Company:
Name, Address, Telephone number, Fax, Email address, Contact person, Importer, Distributor, etc.
2. Product to apply for participating in the Scheme:
Name of products, types, make, model references, countries of origin
3. The party that will be responsible for making and fixing the Energy Label.
4. Commencement date to affix Energy Labels on electronic ballasts packaging
Year _____, Month _____
5. Detailed test reports shall provide at least the following relevant technical data for the electronic ballast :
 - (a) Testing conditions (i.e. ambient temperature, supply voltage and frequency);
 - (b) Lamp lumen output/lamp power for the reference circuit and the test circuit;
 - (c) Reference ballast power and test ballast power loss;
 - (d) Corrected total circuit power for the reference circuit and the test circuit;
 - (e) Operative frequency;
 - (f) Power rating at HF operation; and
 - (g) Comparison between measurement of lamp power and maximum allowable power consumption.
8. Documentary proof that the participating electronic ballast(s) comply with IEC 61347-2-3, Lamp control gear - Part 2-3 : Particular requirements for a.c. supplied electronic ballasts for fluorescent lamps, and/or the Certificate of Safety Compliance prescribed by the Electrical Products (Safety) Regulation of the Hong Kong Special Administrative Region.

Note: *Company's name and chop should be stamped on the all documents provided. All test reports submitted to the office should be certified true copy by appropriate organization.*

Proforma Letter of Acceptance

Your ref.

Our ref. : () EMSD/EEO/LB/29

Tel:

Fax:

Date

┌

Name and Address of
Manufacturers/Importers/Agents

└

Dear Sir/Madam,

Acceptance of Application for Registration in The Hong Kong Voluntary Energy Efficiency Labelling Scheme for Electronic Ballasts

With reference to your letter of ref. _____ dated _____, we are pleased to inform you that your application to participate in the captioned scheme has been accepted.

We enclose herewith the registration certificates of electronic ballasts registered. The registered electronic ballasts are as follows:

| <u>Brand/Make Model</u> | <u>Registration No.</u> | <u>Effective date</u> |
|-------------------------|-------------------------|-----------------------|
| (_____) | (_____) | (_____) |

You are allowed to affix a specified energy label onto each and every electronic ballast package registered under the Scheme. The contents of the energy label should be based on the information that you have provided in your application ref. _____ and dated _____.

Should you have any queries regarding the Scheme, please contact this office.

Yours faithfully,

for Director of Electrical & Mechanical Services

Proforma Letter of Rejection

Our ref. : () EMSD/EEO/LB/29

Your ref.

Tel.

Fax.

Date

[

Name and Address of
Manufacturers/Importers/Agents

]

Dear Sir/Madam,

Rejection of Application for Registration in The Hong Kong Voluntary Energy Efficiency Labelling Scheme for Electronic Ballasts

With reference to your letter ref. _____ dated _____, We regret to inform you that your application for registration to participate in the Scheme has not been accepted for the following reasons:-

1. _____,
2. _____, etc.

You are most welcome to submit new application again in future, when you have the necessary documents / information to support your application.

Yours faithfully,

for Director of Electrical & Mechanical Services

The Hong Kong Voluntary Energy Efficiency Labelling Scheme
for Electronic Ballasts
Flow Chart of Registration

