

Guidelines on

Energy Efficiency of Lift & Escalator Installations

2007 EDITION

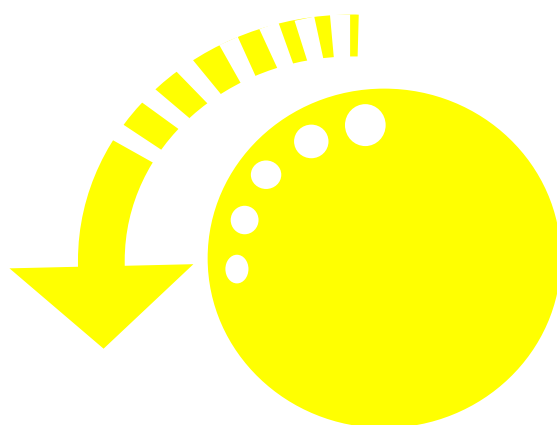

the
Supplement
to the
Code
document

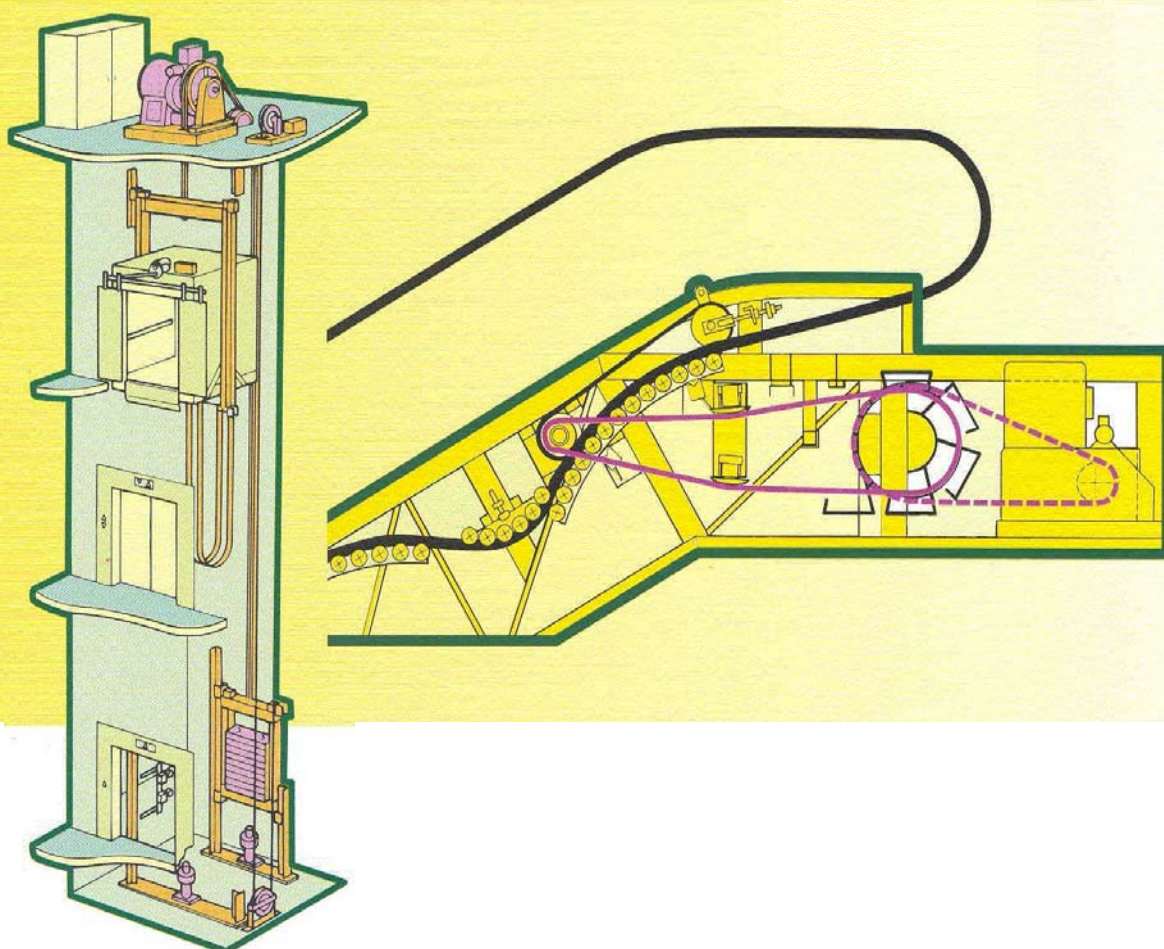

EMSD



Preface

The Code of Practice for Energy Efficiency of Lift & Escalator Installations (Lift & Escalator Code) developed by the Electrical & Mechanical Services Department (EMSD) aims to set out the minimum design requirements on energy efficiency of lift & escalator installations. It forms a part of a set of comprehensive *Building Energy Codes (BEC)* that addresses energy efficiency requirements in building services installations. The set of comprehensive BEC covers the Lift & Escalator Code, the Codes of Practice for Energy Efficiency of Lighting Installations, Air Conditioning Installations and Electrical Installations, and the Performance-based Building Energy Code.

As a supplement to the Lift & Escalator Code, the EMSD has developed this handbook of Guidelines on Energy Efficiency of Lift & Escalator Installations (Guidelines). The intention of the Guidelines is to provide guidance notes to compliance with the Lift & Escalator Code and draw attention of lift & escalator designers & operators to general recommended practices for energy efficiency and conservation on the design, operation & maintenance of lift & escalator installations. The Guidelines seek to explain the requirements of the Lift & Escalator Code in general terms and should be read in conjunction with the Lift & Escalator Code. It is hoped that designers will not only design installations that would satisfy the minimum requirements stated in the Lift & Escalator Code, but also pursue above the minimum requirements.

The Guidelines were first published in 2000. With the Lift & Escalator Code upgraded to its 2005 edition, an addendum for the Guidelines was issued in 2005. The Guidelines are amended in 2007 to suit the 2007 edition of the Lift & Escalator Code.

To promote the adoption of the BEC, the Hong Kong Energy Efficiency Registration Scheme for Buildings was also launched. The Registration Scheme provides the certification to a building complying with one or more of the BEC.

This book of Guidelines is copyrighted and all rights (including subsequent amendments) are reserved.

Acknowledgement

In the preparation of the Guidelines, reference has been made to the following publications:

- a) CIBSE Guide D – Transportation Systems in Buildings, CIBSE
- b) Barney, G.C., and Dos Santos, S.M., Elevator Traffic Analysis Design and Control, Peter Peregrinus, 1995 [Relevant contents quoted are: 2.8.2 (p57, 58), 3.1 (p85), 3.3.3 (p95), Table 2.3 (p51), and Examples 2.11 & 2.12 (p65 to 67)]
- c) Stawinoga, Roland, “Designing for Reduced Elevator Energy Cost”, ELEVATOR WORLD magazine, Jan 1994
- d) Al-Sharif, Lutfi, Bunching in Lifts, ELEVATOR WORLD magazine, Jan 1996
- e) Malinowski, John, Elevator Drive Technologies, ELEVATOR WORLD magazine, Mar 1998
- f) Guide Notes on Elevators (Lifts) Planning, Selection and Design, 1997, Department of Public Works & Services, Australia [Relevant contents quoted are: 7. Electrohydraulic Lifts]

The Building Energy Codes, corresponding Guidelines and Registration Scheme documents are available for download at <http://www.emsd.gov.hk/emsd/eng/pee/eersb.shtml>

Enquiry: hkeersb@emsd.gov.hk

CHECK WEB-SITE FOR LATEST INFORMATION

CONTENTS

1. INTRODUCTION	1
2. CODE COMPLIANCE.....	1
2.1 Maximum Allowable Electrical Power of Lifts, Escalators and Passenger Conveyors	1
2.2 Energy Management of Lifts, Escalators & Passenger Conveyors	2
2.3 Power Quality Requirements	2
3. CONSIDERATIONS IN DESIGN OF LIFTS & ESCALATORS.....	3
3.1 Factors That Affect Energy Consumption of Lift and Escalator System.....	3
3.2 General Principles to Achieve Energy Efficiency	3
4. ENERGY EFFICIENCY FOR LIFT AND ESCALATOR EQUIPMENT.....	4
4.1 General	4
4.2 Traction Lift Equipment	4
4.2.1 Motor Drive Control System	4
4.2.2 Motor Drive Gears	6
4.2.3 Motor	7
4.2.4 Other Means to Reduce Running Friction	7
4.3 Hydraulic Lift Equipment	8
4.3.1 Main Components	8
4.3.2 Basic Arrangements	8
4.3.3 Valve Unit	9
4.3.4 Energy Efficiency for Hydraulic Lift Equipment	9
4.4 Escalator and Passenger Conveyor Equipment	11
4.4.1 Motor Drive Control System	11
4.4.2 Motor Drive Gears and Power Transmission	12
4.5 Power Quality of Equipment	12
4.6 VVVF Motor Drive, Energy optimizer, Service-on-demand Escalator	14
5. ENERGY EFFICIENCY FOR DESIGN OF LIFT AND ESCALATOR SYSTEM.....	14
5.1 Appropriate Sizing of Vertical Transportation System	14
5.2 Appropriate Zoning of Lift Installations	16
5.3 Energy Management of Lift System	17
5.3.1 Provisions of Metering Devices	17
5.3.2 Control Algorithm of Lift	17
5.3.3 Standby Mode of Lift Equipment	18
5.4 Energy Management of Escalator and Conveyor System	19
5.4.1 Provision of Metering Devices	19
5.4.2 Standby Mode of Escalators and Conveyors	19
5.5 Internal Decoration of Lift Cars	19
5.6 Lift Traffic Design	19
5.7 Handling Capacity of Lift System	21
6. HOUSEKEEPING MEASURES TO ENHANCE ENERGY EFFICIENCY.....	22
7. MODERNISATION OF OLD EQUIPMENT.....	23
APPENDIX I – SAMPLE CALCULATION FOR LIFT TRAFFIC ANALYSIS	25

1. INTRODUCTION

The primary objective of the Code of Practice for Energy Efficiency of Lift & Escalator Installations (Lift & Escalator Code), published by the Electrical and Mechanical Services Department (EMSD), is to set out the minimum energy-efficient design standards for lift & escalator installations without imposing any adverse constraint on building functions, nor hindrance to comfort or productivity of the building occupants. The Guidelines on Energy Efficiency of Lift & Escalator Installations (Guidelines) is a supplement to the Lift & Escalator Code. The intention of the Guidelines is to explain the principles behind relevant requirements in the Lift & Escalator Code and provide guidance on Code compliance. The Guidelines also provide the recommended general practices for energy efficiency and conservation on the design, operation & maintenance of lift & escalator installations. Whilst focusing on energy efficiency aspects, the Guidelines are not to provide a comprehensive set of guidance notes in lift & escalator design.

2. CODE COMPLIANCE

The Lift & Escalator Code mainly controls the following areas:

- The maximum allowable electrical power of lifts, escalators & passenger conveyors.
- Energy management of lifts, escalators & passenger conveyors
- Total Harmonic Distortion and Total Power Factor for motor drive system.

2.1 Maximum Allowable Electrical Power of Lifts, Escalators & Passenger Conveyors

The requirement of the maximum allowable electric power indicates ultimately the energy performance of the equipment. The power for lift equipment is to be measured when the lift is carrying its rated load and moving upward at its contract speed. For escalators and passenger conveyors, since the rated load is usually defined as number of person (not in kg weight), there is no theoretical rated load in kg for the equipment. Thus the electric power is to be measured when the escalator/conveyor is carrying no load and moving at its rated speed either in the upward or downward direction. Control figures are given in the Lift & Escalator Code.

For lift equipment, the power is measured at full load contract speed. A number of factors will affect this power consumption. In the case of suspension lift, the weight of the lift car will usually be balanced by the counterweight. Thus if power is measured at the contract speed, the factors that affect the power consumption will be primarily the proportion of the full load that is balanced by the counterweight. In usual lift machine design, the counterweight is usually sized to balance the weight of the lift car plus 45%-50% of the contract load. If the counterweight is designed to balance 45% of the contract load, the power consumption at the full load contract speed up condition will be higher. Other factor that has significant effects on this power consumption is the efficiency of the motor, friction, the controller and the gear box. For hydraulic lifts, the dead weight of the lift car is the predominating factor on this maximum running power as there is no counterweight to balance its dead weight.

In escalator and passenger conveyor equipment, the dominating factor is similar to the traction lift equipment. That is, the efficiency of the motor, friction, the controller and the driving gear box. The proportion of frictional loss of the machine can also become significant in the power consumption in no load condition, as it is the fix overhead to keep the equipment running.

For lift and escalator system designers, it is difficult to obtain this power figure during the design stage because most of the lift manufacturers can only provide the motor's power rating figure of their equipment which is much larger than the running power. This running power can only be measured during the testing and commissioning process, thus it is

difficult to tell exactly during the design stage whether a certain piece of equipment comply with the Code. It is therefore, advisable to look at testing and commissioning records of similar installations when rated power is obtained from lift manufacturers.

In order to meet the allowable electrical power, some good engineering practices for traction lift are:

- Lift machine to locate directly above the lift shaft to avoid losses through additional pulley mechanism;
- Maximum rise (m) to limit to $50 (s) \times \text{Speed (m/s)}$ to minimize the travel distance and thus the energy consumption;
- Maximum rise (m) to limit to 40m for under slung type roping arrangement with basement/side type traction, so as to minimize the travel distance and thus the energy consumption; and
- Avoid blind hoist way above the top most landing to minimize the dead weight of ropes.

2.2 Energy Management of Lifts, Escalators & Passenger Conveyors

For the purpose of energy management, the Code requires that metering devices or provision for meter connection be provided for taking readings concerning energy performance. The readings taken can help to compile a better picture of building energy consumption during energy audit and let building owners know the running costs that they are paying for their vertical transportation system.

The Code has allowed flexibility for equipment installations. The provision of only a connection point with reasonable accessibility and spacing is acceptable to the Code while the ideal provision is to provide the metering equipment together with the lift/escalator equipment. It should be noted that the word "provision" should refer to permanent provisions. Metering devices or measuring provisions are not required for individual equipment. Instead only one set of metering device or provision is required for each *group* of escalators/conveyors or each *bank* of lift. The readings that are required include voltage, current (both line and neutral current), total power factor, energy consumption, power and maximum demand. Multi-function meter that can measure multiple figures is acceptable and recommended. In fact using multi-function meter can simplify the installation work.

Besides the metering requirement, the Code requires that for lift banks with two or more lift cars, at least one lift car should be operated under a "standby" mode during off-peak period. It is also required that during the standby mode, the lift should not response to passenger calls until it is returned to normal operation mode. It merely means to shut down one of the lifts in the lift bank during off peak hours. Additionally, if the lift car's motor drive is DC-MG type motor drive, it is required that the generator driving motor of the lift car should be shut down during the standby mode. As most of newly installed lift equipment in Hong Kong are VVVF equipment, this requirement is expected to have very little impact to the lift industry.

Another requirement is to shut off the ventilation fan while a lift car has been idled for more than 2 minutes. The reason for not shutting down also the lift car lighting is merely due to safety considerations.

2.3 Power Quality Requirements

The power quality requirements in the Code mainly set out in form of Total Harmonic Distortion requirement and Total Power Factor requirement. Relevant reference materials concerning power quality requirement can be obtained from the *Guidelines for Energy Efficiency of Electrical Installations* published by the Electrical and Mechanical Services

Department. Designers should note the measuring conditions and locations of the power quality requirements. For escalators installations, since the requirement of Total Power Factor is to be measured under the motor brake load condition, which is difficult to simulate on site, thus, manufacturer's calculations or proof of compliance will be considered acceptable.

3. CONSIDERATIONS IN DESIGN OF LIFTS & ESCALATORS

The lift and escalator industry is a very unique trade among other building services equipment industries. The equipment suppliers usually have lines of basic products. However, each installation is site specific. That is, the final installation is tailor-made to suit individual site's constraints and requirements. This makes the establishment of generic energy efficiency standard a difficult task, as there are large diversities among different installations.

3.1 Factors That Affect Energy Consumption in Lift and Escalator System

Energy is consumed by lift and escalator equipment mainly on the following categories:

- Friction losses incurred while travelling.
- Dynamic losses while starting and stopping.
- Lifting (or lowering) work done, potential energy transfer.
- Regeneration into the supply system.

The general approach to energy efficiency in lift and escalator equipment is merely to minimize the friction losses and the dynamic losses of the system. There are many factors that will affect these losses for a lift and escalator system:-

(A) Characteristic of the equipment

- The type of motor drive control system of the machine.
- The internal decoration of the lift car.
- Means to reduce friction in moving parts (e.g. guide shoes).
- The type of lifts and escalators.
- The speed of the lift/escalator system.
- The pulley system of the equipment.

(B) Characteristic of the premises

- The population distribution of the premises.
- The type of the premises.
- The height of the premises.
- The house keeping of the premises.

(C) The configuration of the lift/escalator system

- The zoning of the lift system.
- The combination of lift and escalator equipment.
- The strategies for vertical transportation.
- The required grade of service of the system.

3.2 General Principles to Achieve Energy Efficiency

In general the principles for achieving energy efficiency for lift/escalator installations are:

- Specify energy efficiency equipment for the system.
- Do not over design the system.
- Suitable zoning arrangement.
- Suitable control and energy management of lift equipment
- Use light weight materials for lift car decoration.
- Good house keeping.

4. ENERGY EFFICIENCY FOR LIFT AND ESCALATOR EQUIPMENT

4.1 General

The mode of vertical transport in buildings can be mainly classified into three modes:

- by stair traffic
- by lift traffic
- by escalator traffic

Each of these modes of vertical transport has their own characteristics and limitations.

Despite the vast diversified usage of the lift equipment, there are basically two main categories of lift equipment, namely traction lift and hydraulic lift. From energy performance point of view, traction lift is more energy efficient than hydraulic lift system. In hydraulic lift installation, a considerable amount of energy is wasted in heating up the hydraulic fluid when building up the hydraulic pressure. Some installations may even need separate coolers to cool down the fluid to avoid overheating. Furthermore, hydraulic lifts are usually not provided with a counterweight. Thus the lift motor has to be large enough to raise the rated load plus the dead weight of the car cage. In traction lift, the maximum weight to be raised under normal operation is only about half of its rated load. Therefore, designers should avoid using hydraulic lifts if there is no constraint on the installation of traction lift equipment.

4.2 Traction Lift Equipment

4.2.1 Motor Drive Control System

Electricity is directly consumed by the motor drive system of the lift machine. Thus how effective the motor drive can convert the electrical energy into the required kinetic energy have a remarkable effect on the energy performance of the equipment. In the history of lift equipment development, different types of motor drive system were developed. Some of these motor drive systems include:

- DC motor drive with generator set (DC M-G).
- DC motor drive with solid state controller (DC SS).
- AC 2 speed motor drive.
- AC motor drive with variable voltage controller (ACVV).
- AC motor drive with variable voltage and variable frequency controller(ACVVVF).

Among the above drive systems, DC M-G has the lowest efficiency because of large energy loss in the motor and generator arrangement, which converts electrical energy into mechanical energy and finally back to electrical energy again. Another reason for the low efficiency of the DC M-G motor drive is that the motor has to be kept running when the lift is idle.

Similarly, the AC 2 speed motor drive is also considered a less energy efficient drive system. These two speed motors are usually started up with resistance in the high-speed winding, whilst smooth deceleration is obtained by inserting a buffer resistance, either in the low- or high-speed winding during transition to low speed. Sometimes, a choke is used instead of a buffer resistance, which results in a smoother and less peaked curve of braking torque. The insertion of buffer resistance and choke wastes much energy during the start up and deceleration. Furthermore, two-speed system is installed with a large flywheel to smooth the sudden change in torque. The flywheel stores energy, which is dissipated later, contributing to the low system efficiency.

Guidelines on Energy Efficiency of Lift & Escalator Installations, 2007

A general guideline on the motor drive system for traction lift equipment is shown in the following table:

Contract Speed V (m/s)	Suggested Order of Preference Motor Drive Control Systems for Passenger Traction Lifts
$V \leq 1.0$	AC VVVF / AC VV / DC SS / AC 2-speed
$1.0 < V \leq 3.0$	AC VVVF / AC VV / DC SS
$3.0 < V \leq 5.0$	AC VVVF / AC VV
$V > 5.0$	AC VVVF

DC M-G set is not in the guideline throughout the range as the energy performance is extremely poor. The AC-2 speed motor drive system is not recommended for lifts with contract speed higher than 1 m/s due to their inferior energy performance. It is highly recommended that even for lift with speed under 1 m/s, building designers should always consider to use AC VVVF whenever feasible. As an illustration on the energy saving potential for utilizing VVVF drive, let's take the energy of a lift with a pole-changing motor as 100%. Then the ACVV system requires approximately 70% of this energy for the same output whereas ACVVVF will only require 50%. If the energy to be fed back into the mains supply is taken into account, a further reduction of 5% (i.e. 45%) of energy can be achieved for the ACVVVF.

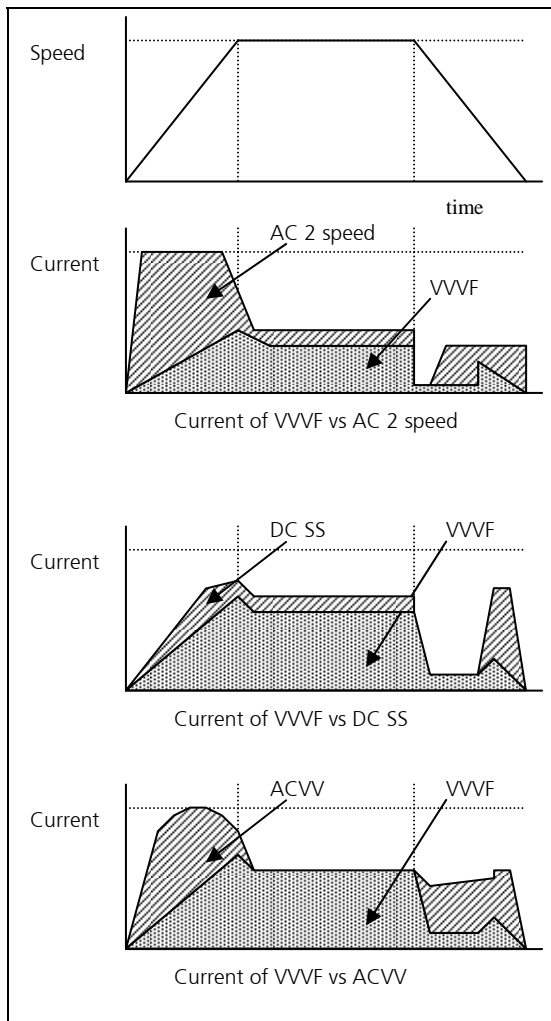

This diagram is for reference only

The figure on the left illustrates the operating characteristic of some motor drive systems during an ideal journey of a lift car. The ideal journey includes a linear acceleration, contract speed travel and a linear deceleration. The energy consumed for the journey should be proportional to the area under the current line of the corresponding motor drive system, that is:

$$energy \propto \int_0^T I(t) \cdot dt$$

Thus it can be seen that a significant proportion of energy has to be consumed during the acceleration process as well as the deceleration process. VVVF motor drive consumes less energy during the start/stop cycle of the lift car. The saving is more remarkable when it is compared with an AC 2 speed motor drive system. It has also been stressed that in real life applications a remarkable proportion of lift journeys are non-ideal journey. That is, the contract speed of the equipment is not achieved. In this case, the lift equipment is always operating in an acceleration/deceleration cycle, which is the most energy-consuming mode.

Besides energy concern, ACVVVF also provides good riding comfort due to the smoothness of speed control.

4.2.2 Motor Drive Gears

The motor drive system is basically either geared or gearless type. Gearless drive usually is for high speed lifts with contract speed above 5 m/s. Equipment suppliers recently start to extend the usage range of gearless drive to the low speed range. Although the original intention is to reduce the size of the machine, the elimination of gear improves the energy efficiency of the equipment. For most of the low and medium speed lifts, the sheave wheel is usually driven by gears. In terms of energy performance, gearless drive has no gear transmission loss thus have a transmission efficiency of 100%. However, the disadvantage for gearless motor drive lies with the fact that multiple-pole motor windings, which generate large magnetic leakage, are needed to attain the necessary rpm. For low and medium speed lifts, due to the difference between the rotating speed of the motor shaft and the required rotating speed of the sheave wheel, a gear is required to reduce the speed of the motor. However, the gear will dissipate some energy as heat generation due to friction in the gear train. Thus the transmission efficiency is more inferior to gearless machine. Low and medium speed lifts usually use irreversible worm gears for which the transmission loss is comparatively high. The advantages of worm gear are precise speed control, good shock absorption, quiet operation, and high resistance to reversed shaft rotation. The efficiency of the gear train depends on the lead angle of the gears and the coefficient of friction of the gear materials. The lead angle is the angle of the worm tooth or thread with respect to a line perpendicular to the worm axis. As this angle approaches zero degrees, the reduction ratio increases, there is more sliding along the gear teeth, and the efficiency decreases. They are usually in the range of 50% to 94%. The efficiency also depends on the operating parameters of the gear train. Usually, smaller reduction ratios, higher input speeds to the worm, and larger sizes result in greater efficiency. However, it does not mean that energy can be saved by over-sizing the gear train because the gear train operate less efficiently at partial load condition.

Some new machines currently in the market utilise helical gears that have higher efficiency than worm gears. The gear train experiences less sliding between gear teeth thus the efficiency is higher than worm gears. According to information provided by manufacturers, the transmission efficiency of helical gears is roughly 10% higher than that of worm gear. Thus enhancing the overall mechanical efficiency of the lift equipment. Like worm gears, over-sizing the gear train will not result in energy saving.

Planetary gears are also used by some of the equipment manufacturers to replace the low efficiency worm gears. Manufacturer claim that by utilizing planetary gears, an overall annual saving of about 34% can be achieved when compared with worm gear systems.

4.2.3 Motor

Motor that can be used for traction lifts are DC motors, AC asynchronous motors, or AC synchronous motors.

DC motors have good control characteristics. The lift car acceleration/deceleration dynamics can be easily controlled due to the torque stability at the low speed range. The merit of DC motors is therefore the achievement of good riding comfort. However, DC motors are bulky in size and expensive in price. The brushes in the DC motors add complications to the maintenance works and motor operating noise.

In order to be installed in lift equipment, AC asynchronous motors are usually multi-pole design and operated in low frequencies. The power factor for such design is usually below 0.7, which render the efficiency of the motor to below 70%. Furthermore, torque pulsation is a problem for AC asynchronous motors operating at low frequency and low speed range.

Recent development has started to install synchronous motor in the traction drive of lift equipment. With the advancement of magnet material, permanent magnets are used in some of the synchronous motor. Compared with asynchronous motors, the permanent magnet synchronous motors are claimed to save energy by 30-50%. This saving is a result of the complete elimination of excitation current and the high power factor (~0.9) achieved.

4.2.4 Other Means to Reduce Running Friction

As stipulated before, one of the energy losses of lift equipment is the friction during its operation. In modern lifts, various methods are employed to reduce the friction loss during operation. Some of these measures are:

- Using high efficiency transmission gears to reduce transmission loss.
- Using roller bearings for the sheave shaft.
- Suspending the car from a point above its centre of gravity instead of from the geometrical centre of the crosshead so as to reduce the side thrust on the guide shoes.
- Using roller guide shoes instead of sliding guide shoes.
- Use less number of pulleys. Fewer pulleys induce smaller losses. If the motor is mounted below, it is more efficient to locate the traction sheave in the hoistway than to have two additional pulleys to divert the ropes from the machine room into the hoistway.
- Use larger diameter pulleys. The larger the pulleys' diameter, the lower the tensile force required for the rope to overcome the frictional moment of the bearings.
- Use thinner rope and larger diameter traction sheave and rope pulleys. This can reduce the internal friction losses. On the other hand, the external frictional losses from the rope can be reduced also in the traction sheave – by not designing for an excessively high traction effort and lower specific pressure for the rope in the groove of the sheave; and in the rope pulleys – by their having low moments of inertia and grooves of a material with good gliding qualities (e.g. use polyamide rope pulleys instead of cast iron).

4.3 Hydraulic Lift Equipment

A hydraulic lift installation consists of an electric motor and a pump unit. The oil pressure generated by the pump acts on the ram in the cylinder. The lift car, which is attached to the top of the ram, moves as the ram moves upwards. The electric motor is not required on descend. A "Down" valve is opened to allow the oil to flow back to the tank for the lift downwards movement. Hydraulic lift is in general not energy efficient due to the reasons as stipulated earlier. Designers should always consider to use traction lift before going to the hydraulic lift option.

4.3.1 Main Components

The main components in a hydraulic lift include:

- A tank unit, which consists of a motor, a screw, a pump and valve unit. The motor and the pump are immersed in the oil whereas the valve unit is installed externally on the top of the tank.
- A cylinder and ram unit. The ram moves within the cylinder, which acts as protection to the ram's uniform smooth finish. A cylinder head is attached to the cylinder with clamping rings.
- Split guide rings (prevent sideways movement of the ram).
- Ram seal (prevent leakage of oil past the cylinder head).
- Scraper ring (prevent scoring of the ram by removing foreign substance before ram returns to the cylinder).
- Bleed screw (for removing air in the hydraulic system).
- O-rings (provide seal between cylinder head and cylinder).
- A controller, which operates the valves and control the directions of the car.

4.3.2 Basic Arrangements

There are 3 basic lift car arrangements:-

- Direct Acting – The cylinder is placed inside a caisson, which is embedded in the ground. The ram is then attached to the bottom and normally at the centre of the car frame. Bore is required for the installation of the caisson. There is no real benefit of having direct acting arrangement. However, some argue that this arrangement is suitable for lifting heavy load.
- Side Acting – This is the most popular arrangement. The cylinder unit sits at the bottom of the lift pit against a wall. Guide rails are required to guide the ram in a vertical plane. The ram is attached to the top of the car frame.
- Rope hydraulic – This arrangement is used to increase the speed of the lift by a 2:1 roping ratio. The cylinder installation is similar to that of side acting except that a sheave is attached to the top of the ram. Ropes are passed over the sheave with one end attached to the pit and the other end to a safety gear under the car. The safety gear can be operated by the slack rope method or by a governor.

Besides the above basic arrangement, hydraulic lift can be installed with more than one cylinder according to the rated load that the lift is going to be operated. These multiple jacks machines follow one of the above 3 arrangements and with the cylinders connected together hydraulically.

4.3.3 Valve Unit

The valve unit controls the lift operation – acceleration and directions. It consists of 3 chambers – the pump chamber, the high-pressure chamber, and the low-pressure chamber. The pump chamber contains a by-pass valve and a pump relief valve. The high-pressure chamber contains a check valve, a main down valve and a down leveling valve. The low-pressure chamber is connected to the tank by a return pipe.

4.3.4 Energy Efficiency for Hydraulic Lift Equipment

Hydraulic lift itself is basically not an energy efficient machine when compared with traction lift. Energy is drained in the following ways:

- Energy loss in motor driving the hydraulic pump during the conversion of electricity into kinetic energy.
- Energy loss in the hydraulic pump itself.
- Energy loss in the valve unit due to pressure drop.
- Energy loss in the transmission of the hydraulic fluid.
- The motor drive does not have regeneration characteristic.
- Energy loss as heat dissipation of the hydraulic fluid.
- The system usually does not equipped with counter weight to offset part of the potential energy input required for the lift car.
- The pump is always at constant flow despite the speed of the lift car. If the speed is less than the contract speed (say during acceleration and deceleration), part of the hydraulic fluid is returned to the tank through the by-pass valve. The loss is remarkable when the lift car is accelerating and decelerating.
- In some extreme cases separate cooling provisions (e.g. cooling coils) are required to avoid over heating of hydraulic fluid.
- Friction of moving parts such as the cylinder jack(s), the guide rail etc..

Some hydraulic lifts manufacturers have developed digital control electronic valves to replace the mechanical valve in the system. The product claimed to be able to produce a 30% saving when compared with a traditional hydraulic valve.

More advanced technology has been developed for new frequency-controlled hydraulic drive which differs from a conventional hydraulic drive in that both the motor and the pump are run at a variable speed. With regard to lifting travel, this means that only the amount of oil required to achieve the instantaneous traveling speed has to be supplied. With a conventional hydraulic drive, however, a constant quantity of oil is always required. In the case of frequency-controlled drive, this smaller flow of oil means less electrical energy is consumed, which also result in less heat generation of the hydraulic fluid. A rough estimate indicated that the new frequency-controlled drive requires roughly 50% less energy for lifting travel. The heat balance of the hydraulic lift installation as a whole is improved by around 40%. For the majority of installations, this means an additional savings can be recognised, namely because there is no need for an oil cooler.

The following diagram compares the energy consumption of the hydraulic system with different types of control:

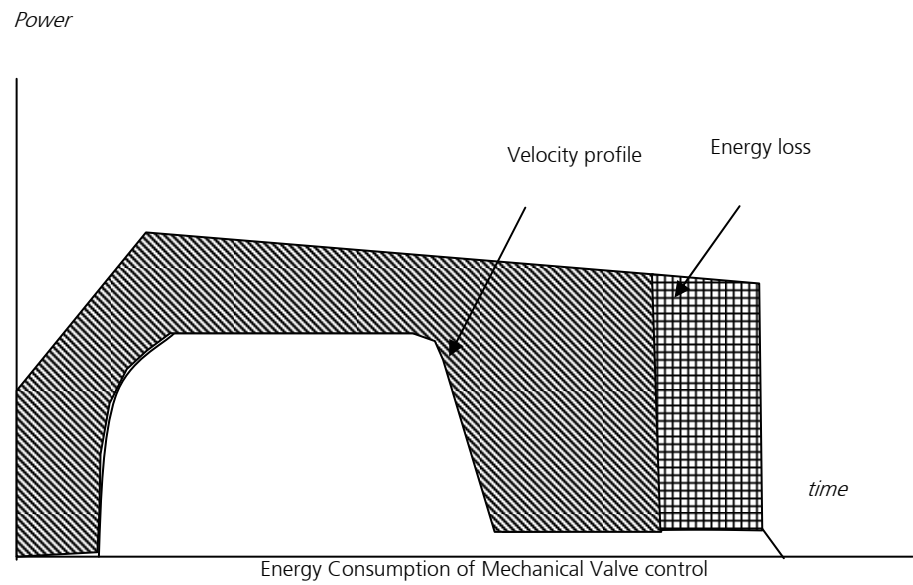
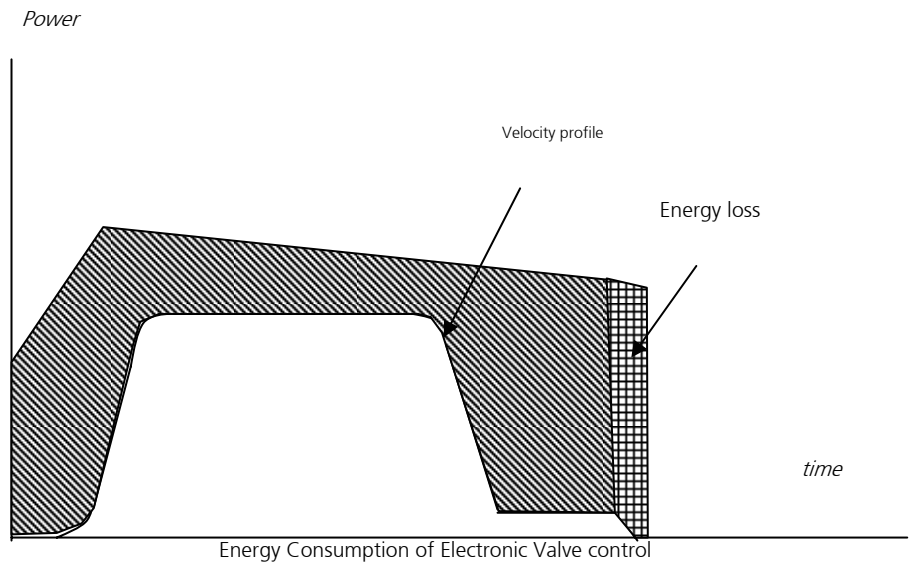
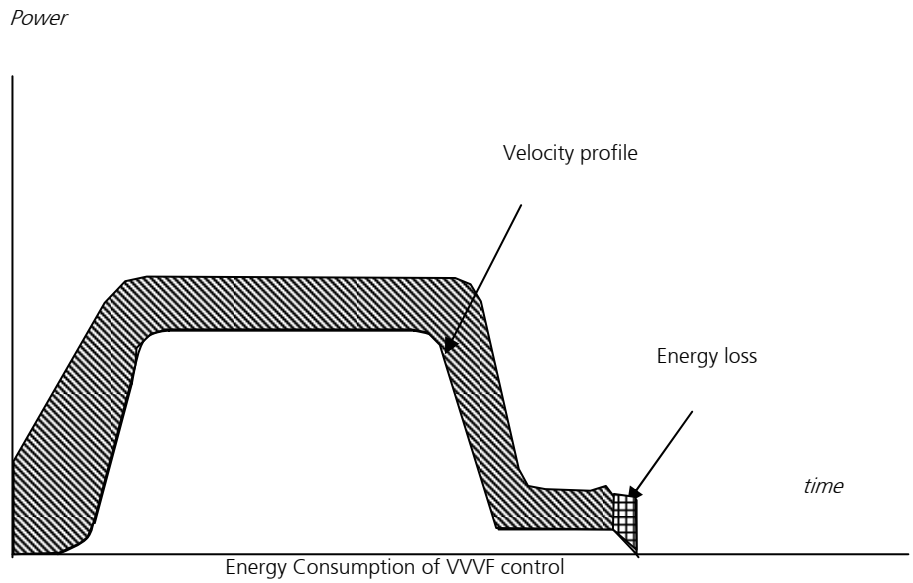

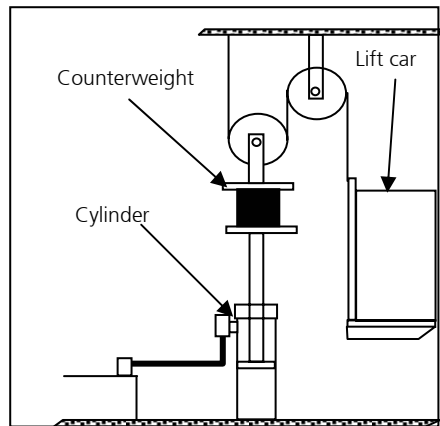

The pull cylinder configuration is another simple way to achieve energy efficiency by incorporating counter weights into the system. The principle of the system is illustrated in the diagram on the left. The hydraulic cylinder is attached to the counter weights instead of the lift car. Instead of pushing the lift car, the cylinder pull the counter weight downwards to lift up the lift car. In this configuration, the cylinder used is smaller than the traditional push cylinder configuration as part of the car weight is balanced by the counter weight and that there is no need to use large cylinder rod

to prevent buckling. Manufacture pointed out that by using this configuration, the motor power is 35%-40% smaller than the traditional configuration. Furthermore, the oil volume of the system is 15% smaller.

To optimise the energy performance of hydraulic lift equipment, the designer should ensure the following:

- The pump and the motor are correctly sized. This is to ensure that the pump is at a working point of acceptable pump efficiency.
- Use light-weight materials for the lift car interior decoration. Since hydraulic lifts usually are not installed with counter weights, the weight of the lift cars has significant effects to the energy consumption when compared with traction lifts.
- If feasible, use a smaller secondary oil pump to maintain lift car leveling instead of the main oil pump.
- Use a mechanical anti-creep device rather than an electrical one.
- Use a pull cylinder configuration and incorporate counter weights into the system.
- If applicable try to reclaim the heat generated in the oil tank for heating purpose.
- Use the new electronic valve or the VVVF hydraulic drive.

4.4 Escalator and Passenger Conveyor Equipment

Escalators are moving stairs, which transport passengers from one landing to another. The drive unit is an electric motor with a sprocket to drive the main shaft. The drive unit is located at the upper truss extension and may be fitted with an over-speed governor. The main drive shaft has sprockets at each end of the axle to drive the step chains. A third sprocket on the main shaft is used to drive the handrail friction newel wheel.

4.4.1 Motor Drive Control System

Unlike the motor drive of lift equipment, the motor drive system of the escalator and conveyor is running all the time disregarding the load condition of the escalator or conveyor. Thus electricity is continuously consumed even there is no passengers on the escalator or conveyor. Much energy is wasted if the number of passengers is widely fluctuating e.g. in public transport stations. Thus, notwithstanding the requirement of the local regulations, much energy can be saved if the speed of the motor drive can be adjusted in according to the passenger transportation frequency. This can be achieved technically by the use of scan sensors or light barriers in passenger guide bars and some controller such as frequency inverter to adjust the speed of the motor. The sensors are usually integrated in the handrail entry caps to detect reflection from individuals and

objects. In case of widely fluctuating operating conditions, a light barrier must be installed in the skirting area of the escalator. A simpler arrangement using a two-speed motor drive system can be such that it operates in slow speed when there is no passenger boarding. The slow speed operation is merely to indicate that the escalator is operating. Once passengers enter a boarding zone, the speed of the escalator is resumed to normal before the passengers actually board on the escalator or conveyor. By adjusting the speed of the escalator to the frequency of passengers an energy saving of up to 30% can be achieved. If a variable speed drive is available, a saving of up to 60% can be achieved.

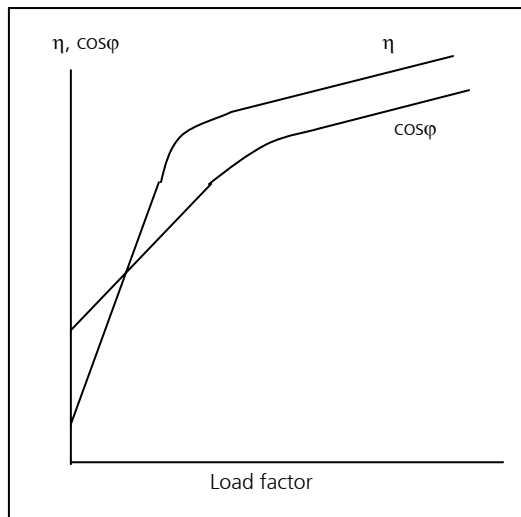

Another way to save energy consumption in the motor drive is to install energy saving equipment (energy optimiser), which can reduce the operating voltage of the motor at light load condition. The principle behind the energy optimiser is based on the fact that most escalators and conveyors are installed with asynchronous motor as the prime mover. The efficiency and power factor of asynchronous motor depend on the load factor (i.e. the ratio of the amount of mechanical load of the motor to the total designed mechanical load of the

motor, see diagram above). When the motor is operating at the nominal voltage and light load condition, the efficiency can be as low as 20%. By lowering the operating voltage, the motor iron loss, which is proportional to the square root of the operating voltage, is reduced. Furthermore, improving the power factor also help to reduce the copper loss of the motor. This kind of energy optimiser is sold in a package to replace the motor starter of the escalator or conveyor. Modification of existing equipment to incorporate the energy optimiser is not complicated. The device senses the load factor of the escalator or conveyor by comparing the phase angle between the current and voltage and adjust the voltage to the motor until the phase difference matches with the preset value. On site testing of such a device within a typical government office building indicates an average saving of about 10% in energy consumption.

4.4.2 Motor Drive Gears and Power Transmission

Like traction lift equipment, a gear box is needed to reduce the motor speed to the speed of the sprocket. It is common for escalators to use irreversible worm and worm-gear transmission for the purpose. Some new escalators use helical gears, which enhance the transmission efficiency by roughly 10%, thus reducing the power consumption of the equipment. The steps of escalators and conveyors are usually driven by chain and sprockets system. Properly lubricated chain and sprocket system can achieve a transmission efficiency of 85% to over 98%, depending on lubrication, load condition and sprocket size.

4.5 Power Quality of Equipment

In an alternating current circuit, electrons flow towards the power source for one half of the cycle and away from the power source for the other half. A device with ideal power quality characteristics neither distorts the supply voltage nor affects the voltage-current phase

relationship. Most incandescent lighting systems do not reduce the power quality of a distribution system because they have sinusoidal current waveforms that are in phase with the voltage waveform (i.e. the current and voltage both increase and decrease at the same time). Electronic circuitry with switching devices may distort current waveforms. For example, VVVF drive with electronics switching devices will draw current in short bursts (instead of drawing it smoothly), which creates distortion in the voltage. These devices' current waveforms also may be out of phase with the voltage waveform. Such a phase displacement can reduce the efficiency of the alternating current circuit.

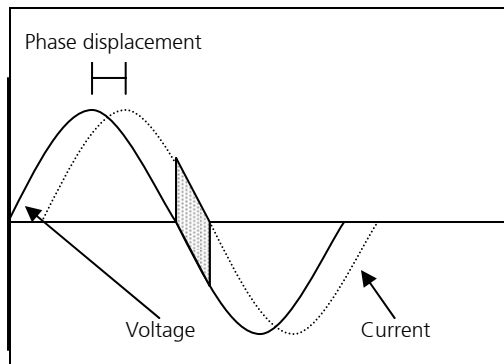

The figure on the left shows a typical case for a current wave lags behind the voltage wave (a typical case for inductive load). During part of the cycle the current is positive while the voltage is negative (or vice versa), as shown in the shaded areas; the current and voltage work against each other, creating reactive power. The device produces work only during the time represented by the non-shaded parts of the cycle, which represent the circuit's active power. Reactive power does not distort the voltage. However, it is an important power quality concern because utilities' distribution systems must have the capacity to carry reactive power even though it accomplishes no useful work.

Another power quality concern is the harmonics. A harmonic is a wave with a frequency that is an integer multiple of the fundamental, or main wave. Any distorted waveform can be described by the fundamental wave plus one or more harmonics. Highly distorted current waveforms contain numerous harmonics. The even harmonic components (second-order, fourth-order, etc.) tend to cancel out each other's effects, but the odd harmonics tend to add in a way that rapidly increase distortion because the peaks and troughs of their waveforms often coincide. The measurement of harmonics is most commonly in terms of total harmonics distortion (THD). Devices with high current THD contribute to voltage THD in proportion to their percentage of a building's total load. Thus, high wattage devices can increase voltage THD more than low wattage devices. It is recommended that designers should include filters to minimize THD when specifying electronic drive systems.

Power factor is a measure of how effectively a device converts input current and voltage into useful electric power. It describes the combined effects of current THD and reactive power from phase displacement. A device with a power factor of unity has 0% current THD and a current draw that is synchronized with the voltage. Resistive loads such as incandescent lamps have power factors of unity. Electronic motor drives should have filters to reduce harmonics and capacitors to reduce phase displacement.

Poor power quality can damage the distribution system and devices operating on the system. In rare instances, poor power quality can cause a dangerous overload of the neutral conductor in a three-phase circuit. In a system with no THD, the neutral wire carries no current. High current THD devices can send odd triple harmonics onto the voltage supply, which do not cancel each other out. They add up on the neutral wire, and if the current exceeds the wire's rating, the neutral conductor can overheat and pose a fire hazard. THD in the supply can result in motor overheating as voltage distortion increases. Fifth-order harmonics produce particularly negative effects as they rapidly degrade the motor's efficiency by producing torque in opposition to normal for part of the cycle. Voltage distortion can also shorten the life of utilities' transformers and cause capacitor banks to fail. Reactive power uses capacity on the distribution system, which limits the amount of active power that a utility can deliver. This may be a problem during periods of peak demand.

4.6 VVVF Motor Drive, Energy optimizer, Service-on-demand Escalator

EMSD has maintained a web-site on energy efficiency technologies <http://ee.emsd.gov.hk/>, in which technologies of the VVVF motor drive, energy optimizer, service-on-demand escalator etc. are introduced.

5. ENERGY EFFICIENCY FOR DESIGN OF LIFT AND ESCALATOR SYSTEM

Besides the equipment itself, the design of the system as a whole would also affect the energy performance of the installation. The design of a vertical transportation system should basically fulfill the vertical transportation needs. The transportation needs of a building depend on the following factors:

- Size of population and its distribution in the premises.
- Pattern of population movement in the premises.
- The quality requirement of the vertical transport service.
- Requirements of the local regulations on vertical transport system.

The key for achieving energy efficiency of the vertical transport system is to ensure an effective utilization of the system and minimize unnecessary wastage. Over design of either the number of lifts or size of lift car will result in energy wastage, especially during the off peak period. On the other hand the over design of contract speed, car cage dead weight and motor rating will consume energy unnecessarily when the lift car is in operation.

5.1 Appropriate Sizing of Vertical Transportation System

Appropriate sizing of vertical transportation system depends on the accuracy of information about the population in premises. This information includes the population distribution and their predicted pattern of flow within the day. Thus it will be more difficult for a "shell building" to obtain the optimum size for the vertical transportation system. Furthermore, the size and pattern of population flow within a building will change throughout the life cycle of the building as new tenant move in and change of business nature.

The need to estimate population size and distribution in a building is not confined to lift and escalator installations. It is also crucial for the design of other services such as the HVAC, provision of toilet facilities or even the planning of the escape route.

Before sizing the vertical transport system, designers should plan the mode of vertical transport (e.g. by mean of stairs, escalator, lift system or a mix of different modes of traffic). This can make the information more realistic for traffic analysis purpose. The most commonly used method of traffic analysis is the "Up Peak" model which is a method to size the vertical transportation system for premises having an "up peak" period (e.g. the hour before the commencement of office hours). In the market, there are computer aided lift design programmes for sizing of lift installations. These programmes can also take care of more complicated scenarios such as peak inter-floor traffic, down peak traffic flow etc. The virtuous of these programmes is to allow designer to experiment with different lift system configurations and control algorithms without the need to carry out tedious calculations and iterations. The reason for employing the up peak model for sizing the lift is because during up peak period, the Handling Capacity of the lift system dominate the degree to which the traffic demand is fulfilled. The Handling Capacity is one of the key parameters for designing a vertical transport system. It is also believed that systems that can cope with the up peak period are also sufficient to handle other traffic conditions.

Guidelines on Energy Efficiency of Lift & Escalator Installations, 2007

Unlike other building services installations which the design calculations give an “exact” prediction of the system performance. All lift traffic analysis methods give result in a probabilistic sense or is a theoretical figure. That is, the calculated performance may not be the same as that in reality but the long-term average performance will be close to the result obtained.

The population basically determined the scale of the vertical transportation system. However, the quality requirement of lift service will also affect the scale as well. Some basic quantities that are used to describe the quality of the service are:

- Handling Capacity:-

Handling Capacity indicates the quantity of service a lift system can provide within a certain period of time, usually 5 minutes (300 seconds). As a result of experience, the number of passengers assumed to be carried each trip is taken as 80% of the contract capacity of the lift car. This does not mean cars are assumed to fill only to 80% of contract capacity each trip but that the average load is 80% of contract capacity. The Handling Capacity can be expressed as number of people or as a percentage to the total population above the terminal floor. When expressed in percentage the Handling Capacity is:

$$HC = 0.8 \times \frac{300 \times CC}{UPPINT \times Pop} = \frac{240 \times CC}{UPPINT \times Pop}$$

where HC = Handling Capacity
CC = Contract Capacity of Lift Car
UPPINT = Up-peak interval
Pop = Population above terminal floor

Typical figure for the Handling Capacity is about 12%-15%. If the Handling Capacity of a lift system is too small, there will be lot of people queuing for the lifts during up peak. Also, the lift cars will have to go more round trips in order to clear off the queue. Thus systems with too small Handling Capacity will degrade the quality of service.

It should be noted that the Handling Capacity stated in an up peak calculation usually does not expect inter-floor travel during the up peak period. If in real case, inter-floor travel is expected during the up peak period, designer can add 1-2% into the Handling Capacity parameter to cover the loss in Handling Capacity due to inter-floor travels.

- Interval:-

The up peak interval of a lift system is the time lap between lift cars depart from the terminal floor during up peak period. It is merely defined by:

$$Interval = \frac{RTT}{n}$$

where RTT = up peak round trip time
n = number of lift cars in lift bank.

For a fixed Handling Capacity, large interval means small number of lift cars and large lift car contract capacity. Lift system with small number of lift cars but large contract capacity will result in inefficient use of energy during off peak hour. Imagine how energy is wasted during off peak hours when there are frequent occasions of only a few people traveling in a large lift car.

Correct sizing of escalator and passenger conveyor equipment is important as well because the motor of the equipment is continuously running and escalators and conveyors are usually installed in group. The size of an escalator and conveyor usually relates to the width of the equipment and also on how many equipment is installed in a group. Though the speed of the equipment also affects the handling capacity of the equipment, the speed of escalator is capped at 0.75m/s and for passenger conveyor at 0.9m/s in Hong Kong. The variation of this speed with individual equipment is not expected to be large. The difficulty in sizing escalator and conveyor equipment lies in the uncertainty in anticipating passenger flow rate. There are not many literatures on how to obtain an optimum size of an escalator or conveyor group. As escalators are usually installed to serve the vertical transportation of only a few floors, an undersized escalator group usually does not have large impact to the passengers as lift installations do because passengers always have other alternatives to go around the floors (e.g. by stairs or lifts).

Appropriate sizing of lift equipment also includes the selection of appropriate contract speed. In general the higher the building is, the faster the contract speed will be. Often in a zoned building the rise from an express zone terminal may be small, e.g. 10 floors, but the express zone jump may be large. It is this express jump, which largely determines the contract speed, to allow journey times to be kept at reasonable values. The following table applies principally to commercial buildings; speeds in residential and institutional buildings may be subject to local design regulations, and similar height buildings may be installed with a wide range of different speed equipment.

Contract speed (m/s)	Lift travel (m)
<1.00	<20
1.00	20
1.50	30
2.50	45
3.50	60
5.00	120
>5.00	>180

5.2 Appropriate Zoning of Lift Installations

Despite the friction loss of lift installation, the dynamics loss during start/stop cycle of lift car is another major energy loss of a lift installation. Thus, from energy point of view, it will be desirable to limit the number of starts/stops cycle for a lift car in order to reduce this energy loss. This can be achieved through appropriate arrangement of lift zoning which subdivide the floors of the premises into clusters of stops to be served by different lift cars. It is by making this arrangement, passengers that travel to a particular floor have a higher chance of being grouped together such that the efficiency of the traffic as well as the energy usage can be improved. Appropriate zoning arrangement will not only improve the energy performance of the lift installation but also improve the handling capacity and the quality of service due to shorter *Round Trip Time*. The improvements are more significant in high rise buildings. The academic institutions have lot of researches on zoning algorithms such as dynamic zoning which can adapt to the changing traffic flow patterns.

For super high rise buildings, researches have indicated that the use of a sky-lobby is an effective solution for vertical transport. The original design intention for the provision of sky-lobby is to reduce the core space for lift systems. Without sky-lobby, there will be difficulties in constructing super high rise buildings because the areas occupy by lift shafts will be substantial in order to meet the traffic needs. That is, the "space efficiency" of the building will be reduced. By incorporating high-speed shuttle lift service and sky-lobby, the lift shafts sizes are reduced and resulting in more floor space for leasing.

The provision of sky-lobby however, can also make the vertical transportation more effective by utilizing super high speeds lifts for the transit between the main terminal and the sky-lobby. The vertical transport of a sky-lobby is usually shuttle lifts. They typically have no more than two primary stops in a tall building due to the volume of traffic they must handle. These lifts must provide maximum handling capacity, consume as little space as possible, and be extremely reliable.

Another aspect to consider for arranging zones is the psychology of the lift passengers. Bad zoning arrangement that result in poor average waiting time will force passengers to call also lift cars of neighbour zones and see which one come first. This will lead to unnecessary wastage of energy. A typical example is separating lift systems to serve even number floors and odd number floors. If the average waiting time is too long, passengers will call for both lift systems and travel one floor by stair.

5.3 Energy Management of Lift System

Besides the equipment itself, some provisions in the lift systems may help to reduce unnecessary energy wastage:

5.3.1 Provision of Metering Devices

The provision of metering devices can provide a convenient means for conducting energy audit. On the consumer side, it provides concrete data for how much electricity is consumed by the lift equipment. This improve the awareness of landlord or property management on the energy management opportunity for the equipment when they have an actual "feel" of the amount of money they are paying for the electricity of the vertical transport. When provision of metering devices is not possible the equipment should at least be provided with suitable accessibility and spacing for connection of these measuring devices.

5.3.2 Control Algorithm of Lift

One of the main factors affecting the effective utilization of a lift system is its control algorithm. Researches showed that the control algorithm has little effect during the up peak period while the effect is much more prominent during the down peak period.

The control of lift systems tackles two different engineering problems. First, some means of commanding a car to move in both up and down directions and to stop at a specified landing must be provided. Secondly, in a group of cars working together, it is necessary to coordinate the operation of the individual cars in order to make efficient use of the lift group. A good quality group control system must distribute the cars equally around the zone in order to provide an even service at all floors. Also it is important that only one car be dispatched to deal with each landing call. Thus, an allocation policy is necessary to determine which car answers each particular call. A common method used to provide such a feature is by grouping the landing calls into sectors within each zone and allocating lift cars to each sector. A sector is a group of landings or of landing calls considered together for lift car allocation or parking purpose.

Most of the lift systems have to tackle the up peak, down peak and peak balanced inter-floor traffic within a working day. Modern group control systems are expected to provide more than one programme or control algorithm to allocate cars to sectors or landings. The appropriate operating programme is determined by the pattern and intensity of the traffic flow encountered by the lift system. In more complex systems

traffic analyser that assesses the prevailing traffic conditions automatically selects the operating programme. Academics are recently combining the use of artificial intelligence and traffic patterns recognition system. Neural networks, which have ability to acquire knowledge, are integrated into the control system for traffic demand recognition. With this new artificial intelligence technology, the lift control will move from demand response to predictive positioning.

For up peak service, the performance of the lift system is less affected by the control algorithm, as by the handling capacity of the lift system prevailing the algorithm during this period. However, the control algorithm has a very significant and determining role in the performance of the lift system during down peak and balanced inter-floor traffic duration.

The lobby or main terminal floor in a building is normally of great importance, owing to the steady flow of incoming passengers. Preferential service is usually provided for these passengers by parking a car at the main terminal prior to any other sector. Although cars are usually parked with doors closed, the car parked at the main terminal floor and assigned as the "Next" car to leave this floor keeps its doors open, ready to receive the incoming traffic. However, if any other cars are stationed at the main terminal, they will keep their doors closed, in order to direct all the passengers to the "Next" car. This "Next" car up feature can help to reduce the so called "bunching" effects. "Bunching" is defined as the situation in which the time interval between cars leaving the main terminal is not equal. When it takes place, system traffic performance is degraded. A typical case of bunching can be seen when the lifts start following each other (or even leapfrogging), as they serve adjacent calls in the same direction. This has a detrimental effect on passenger waiting time. The ultimate case is when all lifts in the group move together, acting effectively as one huge lift with a capacity equal to the summation of the capacities of all the lifts in the group. At this instant the passenger waiting time will be near to the Round Trip Time of the lift cars. Bunching effect will not affect the Handling Capacity of the Lift system. It will only degrade the quality of service by prolonging the passenger waiting time during up peak. Thus the traffic of the lift is less effective. Another adverse effect of bunching is due to the long waiting time for passengers, passengers travel to the floors at the margin of two different zones will tend to call the lift cars service both zones and get on the lift car which come first. This will result in wastage of energy for activating unnecessary lift systems.

5.3.3 Standby Mode of Lift Equipment

As most of the lift equipment has a considerable idling time during off peak hours, landlord or property management may consider putting some of these equipment to a standby mode in order to achieve a more efficient usage on lift equipment.

There are many ways to put the equipment to a standby mode. One of these is to shut down some equipment while keeping the demand during off peak to be handled by the remaining equipment (e.g. shut down one of the lift in a lift bank). The saving can be significant if the lift equipment is using DC M-G set motor drive for which the motor set is kept on running even the lift is being idled.

Other arrangement may be to switch off the lift car lighting and ventilation fan during the standby mode or when the lift is idling. The lights and ventilation fan are switched on again once the control system allocates the lift car for the demand. Both the lighting and ventilation should be switched on before the lift doors open to allow passengers boarding. One should be careful if the lights are being switched off because it may arouse safety problem.

5.4 Energy Management of Escalator and Conveyor System

5.4.1 Provision of Metering Devices

As for lift equipment, the provision of metering devices can provide a useful means for obtaining data for energy audit purpose and review purpose.

5.4.2 Standby Mode of Escalators and Conveyors

Energy management opportunity for escalators and conveyor equipment usually lies with how to reduce power consumption during off peak period. This can be done either manually or by installing sensors to adjust the speed of the equipment according to the demand. The installation of sensors is more suitable for escalators and conveyors with widely fluctuating demand. However, care should be taken to ensure that there is no speed change on the operation of the equipment when passengers are traveling.

5.5 Internal Decoration of Lift Cars

The dead weight of the lift car is a key factor for energy wastage for lift equipment as energy has to be consumed to move it up and down the lift shaft. The use of marbles, granites or other heavy materials will significantly increase the dead weight of the lift car thus deteriorating the energy performance of the system. The effect is more significant for hydraulic lifts, which do not have counter weights for the lift cars. Even for traction lift with a counter weight, the increase in overall lift car weight will increase also the mass of the counter weight. This will increase the system's inertia and therefore will increase the energy required during acceleration/deceleration operation of the lift car.

Besides the decoration materials, further energy saving can be achieved by using energy efficient lighting inside the lift car. Tungsten halogen lamps are less energy efficient than fluorescent/compact fluorescent lamps. For details on the choice of energy efficient lighting, references are available in "*Guidelines on Energy Efficiency of Lighting Installations*" published by the Electrical and Mechanical Services Department.

For outdoor observation lifts, tinted glazing can reduce the heat gain of the lift car thus reducing the cooling requirement of the lift car. Clear glazing can be used for indoor observation lifts but they are not recommended for outdoor purpose unless provisions are allowed to shade the outdoor glazing from direct solar radiation. Should outdoor glazing not be avoidable, use types with low shading coefficient to minimize the solar heat gain.

5.6 Lift Traffic Design

5.6.1 For any passenger lift system which forms the main mode of vertical transportation and fulfilling all of the following conditions, a lift traffic analysis shall preferably be carried out to optimise lift traffic flow:

- the rated speed of any lift car in a lift bank exceeds 1.5 m/s;
- a building that requires lift service and has at least 10 storey; and
- the building usage shall be of the zone type as indicated in the table in paragraph 5.6.2 below.

5.6.2 In the traffic analysis, the Maximum Interval (INT) at up-peak at the terminal floor of a lift bank serving a zone of a particular building usage shall preferably not exceed the maximum values below:

Zone Type	Maximum Interval of a Lift Bank (s)
-----------	-------------------------------------

Guidelines on Energy Efficiency of Lift & Escalator Installations, 2007

Office Zone	30
Hotels	40
Institutional Zone	45
Commercial Zone (Shopping Complex)	30
Industrial Zone	55
Composite Zone	the smallest value of various <i>Maximum Intervals</i> that apply to different zone types of a composite zone (see note 1)

Table 5.6a Maximum Intervals of Lift Banks for Various Zone Types

note 1: premises in a composite zone which do not occupy more than 1.5 percentage of the gross floor area (e.g. estate management office, mutual-aid office within a domestic block) of the zone may be considered not constitute an independent zone type.

The maximum interval requirement does not apply to a lift system that is not the main mode of vertical transportation. An example of this is in a shopping complex with both escalators and lift system, the main mode of vertical transportation is usually by escalators and not by lift system, and the lift system does not have to follow the handling capacity requirement.

- 5.6.3 The Maximum Interval at up-peak of a lift bank is equal to the Round Trip Time (in sec) at the Up Peak traffic condition divided by the quantity of lifts in the lift bank. The Round Trip Time of a lift car refers to a value calculated by Up Peak Model. The Round Trip Time (RTT) could be obtained from the following equation:

$$RTT = 2Ht_v + (S + 1)t_s + 2Pt_p$$

where RTT = Round Trip Time (in seconds)

t_v = time to transit two adjacent floors at rated speed (in seconds)

t_s = time consumed when making a stop (in seconds)

t_p = passenger transfer time for entering *or* exiting the lift car (in seconds)

P = 0.8 x contract capacity of lift car (in person)

The time consumed when making a stop is obtained from the equation:

$$t_s = t_{f1} - t_v + t_o + t_c$$

where t_{f1} = Single floor jump time (in seconds)

t_o = Door opening time (in seconds)

t_c = Door closing time (in seconds)

- 5.6.4 Unless there are sufficient technical information on the door opening and closing times for the lift equipment, the figures in tables below shall be adopted in the lift traffic analysis.

Panel arrangement	Door Size (note 2)			
	0.8 m		1.1 m	
	Ordinary	Pre-Open (note 3)	Ordinary	Pre-Open (note 3)
Side opening	2.5s	1.0s	3.0s	1.5s
Centre opening	2.0s	0.5s	2.5s	0.8s

Table 5.6b Minimum Door Opening Times To Be Used For Lift Traffic Analysis

Panel arrangement	Door Size (note 2)	
	0.8 m	1.1 m
Side opening	3.0s	4.0s
Centre opening	2.0s	3.0s

Table 5.6c Minimum Door Closing Times To Be Used For Lift Traffic Analysis

note 2: For door size other than 0.8m and 1.1m, the operating time shall be calculated by interpolation.

note 3: Also known as Advanced Door Opening. The door panels of the lift car start to open when the car has entered the door zone e.g. say some 0.2m from a landing level. The time is taken from the first application of the brake to doors 90% open.

- 5.6.5 When a lift traffic analysis is carried out, the highest call reversal floor (H) and the average number of stops (S) could be obtained from the following equations, with the passenger transfer time assumed to be 1.0 second:

$$H = N - \sum_{j=1}^{N-1} \left(\sum_{i=1}^j \frac{U_i}{U} \right)^p \quad S = N - \sum_{i=1}^N \left(1 - \frac{U_i}{U} \right)^p$$

where N = Number of floors above main terminal floor
 U = Total population of zone above main terminal floor
 U_i = Population at the ith floor
 terminal floor = the principal floor in a building zone from which lift cars can load and unload passengers.

- 5.6.6 A complication for the requirement in the table in 5.6a lies with the composition zone (i.e. there are more than one single type of floor usage for the zone). In this case, the smallest value of the required maximum interval for the various floor usage types within the zone will be taken as the control value. However, if a certain type of floor usage within the zone does not occupy more than 1.5% of the gross floor area of the zone, the designer can discard this type of usage from the composite zone. This is to avoid unnecessary stringent requirement being imposed on the zone having an insignificant portion of other usage (such as a management office within a residential block).

An example of the calculation based on up-peak is included in Appendix I.

5.7 Handling Capacity of Lift System

- 5.7.1 The following handling capacity shall preferably be followed:

- (i) a lift bank serving a *sky lobby* shall have a passenger handling capacity not less than 20 %, and
- (ii) a lift bank serving *zones* shall have a passenger handling capacity not less than 10 %.

where sky lobby means a terminal floor at the highest floor served by a low-zone group of lifts, where passengers can wait for service by high-zone lifts.

The Passenger Handling Capacity for a lift bank is defined as :

$$\frac{5 \text{ min} \times 60 \times 0.8 \times \text{Lift Car Contract Capacity (no. of persons)}}{\text{Up Peak Interval} \times \text{Population Above Terminal Floor of Zone}} \times 100\%$$

The handling capacity is based on a 5 minutes interval and assuming that the lift cars are filled to 80% of the rated load (in number of persons). The reasons for assuming this 80% are:

- The passenger transfer times are longer for a crowded lift car. For example, the last person usually takes a longer time to enter a fully loaded lift car. Researches have shown that an 80% filled up car has the best performance in terms of round trip times.
- Quantitatively, there are simulation studies, which indicated the up peak performance figure deteriorates drastically for lift cars filling up to 80% and above. The performance figure is obtained by dividing the Average Waiting Time by the Interval. It is a figure indicating the deviation of the actual waiting time from the ideal interval of the system.

5.7.2 However, the following lift systems do not have to follow the handling capacity requirement:

- lift system serving domestic buildings including those on top of podium or commercial centres (shopping complex).
- lift system is not the main mode of vertical transport.
- disable platform.

5.7.3 The Handling Capacity requirement provides a counter balance figure for the Lift Traffic Design requirement in 5.6, as using smaller size cars could achieve the Maximum Interval requirement but not the handling capacity requirement that demands more lift cars or larger size cars.

6. HOUSEKEEPING MEASURES TO ENHANCE ENERGY EFFICIENCY

Housekeeping is also important to ensure efficient use of the lift equipment especially when there are lots of lift and escalator equipment in the building (e.g. in high rise commercial buildings). The key points to maintain efficient equipment usage are:

- Ensure that the equipment are well maintained including regular routine maintenance to keep all moving parts sufficiently lubricated and to detect for early sign of wear and tear.
- Switch off low usage rate equipment during off peak period especially for escalators, conveyors and DC-MG type lift equipment. Optimise the operating hours and programme of the equipment.
- In case of a bank of escalators (e.g. in public transport station), the traveling direction can be adjusted to suit the flow pattern of passenger traffic.
- Monitor equipment operation by carrying out energy audit for the equipment continuously.
- Ensure there is suitable personnel to look after the building services equipment.
- If possible, encourage tenants to use staircases for one or two floors travel.

7. MODERNISATION OF OLD EQUIPMENT

Besides new installations, there are huge numbers of existing old equipment in buildings, which provide opportunities for modernization works. For lift and escalator installations, the need for modernization is seldom solely due to reason of reducing operating cost. In fact, this need usually stems from one of the following reasons, which are more justifiable for the amount of money to be spent:

- An increase in the traffic needs (e.g. a new big tenant moves into the building, change of building usage etc.)
- The old equipment reaches the end of its economic service life (i.e. frequent breakdown occurs, lot of tenants' complaint etc.)
- Renovation of the whole building

There are many difficulties in modernisation of lift and escalator due to constraints in building structure and space. Besides technical constraints, designers always have to take care of the expectation from the owners (e.g. the Landlord) on modernization options. Especially for those owners or decision-makers that have a straightforward series of decisions simply determines which option will do the job for the lowest cost. This kind of decision logic may sometimes hinder designers to use energy efficient options. Depending on the type of building and the services running inside, there are different figures of estimation for the energy dissipation of lifts as a percentage of the energy consumption of the whole building. Research figures estimate that the percentage is in the range of 5-15%. For lift equipment, except in very extreme case, the consideration of payback period alone will not attract building owners' investment in replacing for more energy efficient equipment. A rough estimate indicates that the payback period for incorporating frequency drive with energy feeding back into the mains for an old AC-2 speed drive will be approximately in the order of 10+ years. The driving force towards more energy efficient equipment is in fact come from the competition among manufacturers themselves to produce more energy efficient motor drive and motors, which can surpass their competitors' product of comparable costs. Besides seeking business opportunities, manufacturers who produce high efficient equipment have added benefit of company image of being "politically correct" as well because of their positive environmental impact.

For modernisation work, some of the options to increase energy efficiency of the system that worth considerations are:

● Motor Drive

Unless the building is to have a total replacement of the lift equipment, in most cases, equipment with similar engineering technology are utilised during modernization. For example, DC remains DC, with the generator being replaced by an SCR control. In AC, an inverter or vector drive is used with the AC induction motor to vary the speed instead of using its two-speed windings. However, in some cases on geared machines, the motor is changed for a modern, AC-induction motor replacing the DC or two-speed AC motor. Gearless machines almost always remain with their existing technology because of the high cost of a new motor. These options can help to reduce the energy consumption and the riding comfort of the system. For example, by using a DC SCR control to replace a generator set, current can be more precisely regulated to the motor. With DC tachometer or encoder feedback, the SCR control can provide full torque from the motor at low speeds during approaching and leveling, and to hold the car at the floor in position until the brake can be set.

● Lift car

Reducing the car mass results in an equal reduction in the counterweight; hence, the effect is doubled. However, practically, there are two reasons that restrict the reduction: the lower

the masses of car and counterweight in relation to the contract load, the smaller the traction will become. Secondly, the higher the car mass, the greater the traveling comfort the user will experience.

Notwithstanding the local regulations, light-weight composite materials such as graphite-fiber-reinforced-plastic can be considered as a substitution for steel as car enclosure materials.

Furthermore, energy efficient lighting equipment can be used inside the lift car.

- Rotational mass

Rotational masses on the motor shaft have a particular unfavorable effect, due to the high rpm of the motor. A reduction in these masses can bring about a significant lowering of starting power required. This can, for example, be accomplished by choosing the motor with an inherently low moment of inertia or by repositioning the brake disc onto the slower-moving traction sheave shaft. As speeds increase, the traction sheave and rope pulleys also revolve faster so that they have an increasingly greater influence on the starting output. The diameters of the traction sheave and rope pulleys cannot be reduced indefinitely, but it is possible to use polyamide instead of cast iron for the rope pulleys, thus reducing the moment of inertia by a ratio of approximately 1:5.

- Control system

Incorporation of newer control algorithm and strategies can improve the utilization of the vertical transportation system. Older hard-wired relay control system can be replaced by newer microprocessor systems, which are more flexible, compact and easier to be maintained. Furthermore, sufficient control for shutting down part of the vertical transport system during off peak period can be provided for caretaker or management office for operation purpose.

Appendix I – Sample Calculation for Lift Traffic Analysis

This appendix is an example showing the calculation of a traffic analysis in a lift design process in a hypothetical building using the conventional “Up-peak” method. For detailed theories of the Up-peak analysis, please refer to lift traffic design literatures.

Summary of Equations

Eqn. 1:

$$H = N - \sum_{j=1}^{N-1} \left(\sum_{i=1}^j \frac{U_i}{U} \right)^p$$

Eqn. 2:

$$S = N - \sum_{i=1}^N \left(1 - \frac{U_i}{U} \right)^p$$

Eqn. 3:

$$RTT = 2Ht_v + (S + 1)t_s + 2Pt_p$$

- Where : N = Number of floors above terminal floor to be served by the lift system
- t_v = the interfloor time
- t_s = the operating time = (single floor jump time – t_v +door operating time)
- t_p = passenger transfer time
- P = 0.8 x contract capacity of lift car (in person)
- H = average reversal floor
- S = expected number of stops
- RTT = Round Trip Time
- U = Total population in the building
- U_i = population at floor i

Summary of Steps

Step	Procedures
1	Decide on λ rate of passenger arrivals over 5 mins.
2	Obtain or decide upon lift system data N Number of floors t_v the interfloor time t_s the operating time t_p the passenger transfer time
3	Estimate an appropriate interval or using the designed interval
4	Obtain H the average reversal floor P average car load S expected number of stops
5	Calculate RTT including all secondary effects
6	Select L, the number of lifts to produce an interval close to that estimated in step 3
7	Compare the estimated interval (step 3) with the calculated interval (step 6) and if significantly different, estimate another value for the interval and then iterate from step 4. A possible new trial could be : New INT = INT(step 6) + [INT(step6)-INT(step3)]
8	Select a suitable car capacity, which allows approximately 80% average car load.

Guidelines on Energy Efficiency of Lift & Escalator Installations, 2007

Example

An office block for a single tenant of 24 floors (including the main terminal) of 24,000m² total net area is to be built. The estimated population per floor is 100 persons and the estimated up peak demand is 17%. Design a suitable configuration of lifts using the conventional method. The total travel is 75.9m (typical floor to floor height = 3.3m) and the design interval is 25s.

Other data:

Assume passenger transfer time = 1.2s

Door opening time = 0.8s (advance opening)

Door closing time = 3.0s

Calculation

From design literature for travel of 75.9m, suitable contract speed of lift = 3.5m/s and single floor flight time is approx. 4.0s.

Arrival Rate:

$$\lambda = 23 \text{ floors} \times 100 \times \frac{17}{100} = 391 \text{ persons/5 min}$$

For N=23

$$t_v = \frac{3.3}{3.5} = 0.94s$$

$$t_s = (4.0 - 0.94) + 3.0 + 0.8 = 6.86s$$

$$t_p = 1.2s$$

Design interval or estimated interval, INT = 25s

The Capacity

$$P = \frac{391}{300} \times 25 = 32.6 \text{ persons}$$

The capacity is too large for standard lift product range. Try splitting the system into two groups. That is P=16.3 persons for each group.

From eqn.1 and eqn.2:

$$H = 23 - \left[\begin{aligned} & \left(\frac{100}{2300} \right)^{16.3} + \left(\frac{100}{2300} + \frac{100}{2300} \right)^{16.3} + \left(\frac{100}{2300} + \frac{100}{2300} + \frac{100}{2300} \right)^{16.3} + \dots \\ & + \underbrace{\left(\frac{100}{2300} + \frac{100}{2300} + \dots + \frac{100}{2300} + \frac{100}{2300} \right)^{16.3}}_{22 \text{ items}} \end{aligned} \right]$$

Guidelines on Energy Efficiency of Lift & Escalator Installations, 2007

$$S = 23 - \underbrace{\left[\left(1 - \frac{100}{2300}\right)^{16.3} + \left(1 - \frac{100}{2300}\right)^{16.3} + \dots + \left(1 - \frac{100}{2300}\right)^{16.3} \right]}_{23 \text{ items}}$$

$$H = 22.12$$

$$S = 11.86$$

$$\begin{aligned} \text{RTT} &= 2 \times 22.1 \times 0.94 + (11.86 + 1) \times 6.86 + 2 \times 16.3 \times 1.2 \\ &= 41.5 + 88.2 + 39.1 \\ &= 168.8 \end{aligned}$$

Let number of lift car $L=7$, interval of the system will be:

$$\text{INT} = \frac{168.8}{7} = 24.1\text{s}$$

Try a new value $24.1 + (24.1 - 25) = 23.2$

$$P' = \frac{391}{300} \times 23.2 = 30.24 \text{ persons}$$

Again halving the traffic $P'=15.12$

$$\begin{aligned} H' &= 22 \\ S' &= 11.23 \\ \text{RTT}' &= 161.9\text{s} \\ L &= 7 \\ \text{INT}' &= 23.13\text{s} \end{aligned}$$

This is sufficiently close to the previous calculated INT.

Thus car capacity should be :

$$\frac{15.12}{80\%} = 18.9 \text{ persons}$$

Say select car capacity of 20 persons, which is closest to 18.9 person from the up side.

The configuration of the lift system will be 2 groups of 7 cars with contract capacity of 20 persons. Of course there may be other configurations, and the steps for analyzing the traffic are similar.

Other secondary effects to the round trip time such as unequal inter-floor distance, unequal floor population etc. should be taken into account during the calculation.

The interval in the above example is a design parameter as a requirement of the quality of the lift service. The actual performance of the lift system may be different from the designed figure due to the random nature of occupant arrival. However, the up-peak analysis still gives a good reference to the designer on the quality of service that the system is able to deliver in average.

Energy Efficiency  **EMSD**

Electrical & Mechanical Services Department

Tel: (852) 1823 Fax: (852) 2890 6081

Website: www.emsd.gov.hk

e-mail: hkeersb@emsd.gov.hk