

GU 10

THE GOVERNMENT OF THE HONG KONG
SPECIAL ADMINISTRATIVE REGION

GAS UTILISATION GUIDANCE NOTE 10

CODE OF PRACTICE FOR
THE DESIGN AND CONSTRUCTION
OF LPG CYLINDER WAGON

Issue 1, September 1997
The Gas Authority

CONTENTS

	<u>Page</u>
1. SCOPE	1
2. VEHICLE	1
3. ENGINE	1
4. FUEL TANK	2
5. FIRE-RESISTING SHIELD	2
6. CARGO COMPARTMENT	3
7. EMERGENCY ENGINE STOP	3
8. ELECTRICAL SYSTEM	4
9. IDENTIFICATION	5
10. EQUIPMENT ATTACHED (TAIL-GATE LIFTS & FIRE EXTINGUISHERS)	5
11. MATERIAL	6

Figure 1 - Typical Construction of a Cylinder Wagon

Figure 1.1 - Typical Construction of a Cargo Compartment

Figure 2 - Typical Fire Extinguisher Mounting

Figure 3 - Typical Emergency Engine Stop Notice

Figure 4 - Typical Battery Main Switch Notice

Figure 5 - Typical No Smoking Notice

Figure 6 - Typical Emergency Contact Notice

Annex 1 - Sample of VE 24 : Vehicle Examination Report & Repair Order

Annex 2 - Sample of TD 89 : Motor Vehicle Certificate of Roadworthiness

Annex 3 - Sample of FS 251: Certificate of Fire Service Installations and
Equipment

1. SCOPE

- 1.1. This Code of Practice is issued under Regulation 9 of the Gas Safety Ordinance, Cap. 51. The aim of this document is to list the conditions to be complied with for a cylinder wagon (CW) as detailed in Part 2 of Schedule 2 of the Gas Safety (Gas Supply) Regulations Cap 51 . It also gives a practical guidance for the interpretation of the requirements. .
- 1.2. As this document is a general outline of Part 2 of Schedule 2 of the Regulations, Gas Standards Office (GasSO) reserves the right to revise the whole or any part of this document.

2. VEHICLE

- 2.1. The vehicle shall have at least 9 months of Roadworthiness as shown in "Motor Vehicle Certificate of Roadworthiness" (Form TD 89). For CW permit relicensing, it shall pass the "Overall Examination Evaluation" stipulated in "Vehicle Examination Report and Repair Order" (Form VE 24). Sample of TD 89 and VE 29 are given in Annex 1 and 2.
- 2.2. The cylinder wagon and its equipment shall be in good and efficient working order.

3. ENGINE

- 3.1. The engine shall be a compression-ignition type (for example diesel engine). It shall comply with the definition given in the Road Traffic (Construction and Maintenance of Vehicles) Regulations (Cap.374 sub. leg.).
- 3.2. The engine shall be constructed and situated (e.g. underneath the driver cab) or protected so as to avoid any danger to any cylinder carried by the cylinder wagon.
- 3.3. The air inlet system of the engine should be able to prevent flame propagation due to engine back-fire. Metallic air filter is recommended instead of paper type.
- 3.4. The exhaust system should be installed wholly in front of the fire-resisting shield and the discharge arranged to one side of the vehicle where not affecting the cargo compartment and the fuel tank.
- 3.5. The exhaust system shall be incorporated with a flame arrestor.

- 3.6. The end of the exhaust pipe should not be extended beyond the vehicle body and the fire-resisting shield.

4. FUEL TANK

- 4.1. The fuel tank shall be of double case construction.
- 4.2. The tank shall be fitted with a lock to the filling hole cover or the outer case.
- 4.3. The four bottom corners of the outer case shall have a 10mm (3/8 inch) hole to ensure that fuel can only drain to the ground in the event of a leak from the tank.
- 4.4. The fuel tank shall be separated from the cab of the wagon and protected with fire-resisting shield on top, left, right and back against fire. The wooden chassis behind should not be used as fire-resisting shield. If metallic chassis is used as fire-resisting shield, the holes on the bar should be sealed off.
- 4.5. The tank shall be fitted with steel structure to protect against impact. The steel structure shall be robust and separated with the tank at least 25mm (1 inches). (Refer to Fig. 1)

5. FIRE-RESISTING SHIELD

- 5.1. The fire-resisting shields shall be provided to separate the cargo compartment from the interior of the cab, fuel tank, electrical generator, engine, batteries, switch gear, fuses, air-conditioning system and exhaust system. It shall have at least 30 minutes fire resistance rating steel plate (3mm thickness).
- 5.2. The fire-resisting shield separating the cargo compartment and cab should have at least 150mm (6 inches), it should project upwards to a point above the topmost level of the cargo compartment, and downwards to a point not more than 300 mm (12 inches) from the ground. The shield should be a continuous plate without any breakage except the glass windows and apertures.
- 5.3. If glass windows are provided on the fire-resisting shield, all windows used should be wire glazed (6 mm or 1/4 inch thick) in fixed metal frame and not capable of being opened.
- 5.4. Any aperture made to allow any piping to pass through the fire-resisting shield (engine shaft, air brake tubing, etc.) should be minimised to prevent

the passage of inflammable vapour through the shield. The opening should be made good with appropriate sealant.

6. CARGO COMPARTMENT

- 6.1. Cargo compartment should be constructed with non-combustible material, e.g. metal plate and frame.
- 6.2. For permit renewal only, the wooden compartment should be covered by metal plate.
- 6.3. The floor of the compartment should be robust. It should be supported by metal columns and covered with steel checker plate of 3mm thick (1/8 inch).
- 6.4. It shall have a fixed roof constructed of fire-resistance materials.
- 6.5. It shall be well-ventilated. High and low ventilation holes shall be provided in the cargo compartment. The space between the fencing structure should be less than 180mm.
- 6.6. The low level ventilation shall be at least 1/50 of the compartment floor area and shall be evenly distributed along the sides of the compartment. The distances measured between the compartment floor and the bottom and topmost of the hole shall be less than 150mm + 5mm and 250mm + 5mm respectively. (e.g. total of 8-10 holes with size of 100mmH x 200mmW along the left, right and rear sides of the compartment may be considered to be adequate depending on the compartment floor area.)
- 6.7. It shall be capable of being locked.
- 6.8. The secure door should be operated in sound condition and without any damage.
- 6.9. Corrosion protection (anti-corrosion painting) should be provided for metallic surface of the compartment.
- 6.10. No separate storage compartment should be constructed within the cargo compartment.

7. EMERGENCY ENGINE STOP

- 7.1. An emergency engine stop shall be provided to cut off the supply of fuel to the engine of the wagon, and stop that engine. At the time of inspection, the

driver is requested to demonstrate the operation of the emergency engine stop.

- 7.2. It shall be fixed in an easily accessible location outside the driver cab.
- 7.3. "Emergency Engine Stop" label, in both Chinese and English, shall be prominently and legibly displayed to show the location and the operation method of the emergency stop. (Refer to Fig. 3)
- 7.4. Installation methods include mechanical type, linkage lever type and electrical type. 'T' shape handle with metallic sleeve should be used for mechanical type. Fire-resistant and water-proofing switch box (220V, 15A) should be used for electrical type. All emergency engine stops should be in red colour for easy identification.

8. ELECTRICAL SYSTEM

- 8.1. All electrical apparatus in the cylinder wagon shall be so constructed and installed as to guard adequately against the risk of short circuit and the outbreak of fire.
- 8.2. All electrical apparatus in any enclosed area (e.g. cargo compartment) of the vehicle where an accumulation of liquefied petroleum gas in vapour form may occur shall be designed and constructed for Zone 1 area as defined in BS EN 60079-10: 1996.
- 8.3. The voltage of the electrical circuit shall not exceed 24 volts DC.
- 8.4. The battery should be properly installed in front of the fire-resisting shield. It should not be fixed within the driver cab. Battery cover shall be provided to minimise the chance of short circuit.
- 8.5. Cross sectional area of the main electrical wire of the battery shall have at least 35mm^2 . The positive pole shall be connected to the main battery isolation switch and the negative pole connected to ground.
- 8.6. The main battery isolation switch should be fixed in an easily accessible location within the driver cab and the location of the switch should be clearly labeled. (Refer to Fig. 4) It is preferable to be on the upper left side of the switch board. This switch should be able to isolate all electrical installation, including electrical lamps, speakers, starter, tail lift gate and etc. At the time of inspection, the driver is required to demonstrate the operation of the switch.

- 8.7. All electrical installation should be in sound condition. Non-essential and non-fixed electrical installation are not allowed, e.g. mobile radio, cigarette ignitor, etc.
- 8.8. All electrical connection should not be exposed and the insulation should be sound. Metallic sleeve should be used for cable installed at the posterior side of the fire-resisting shield.

9. IDENTIFICATION

- 9.1. The cylinder wagon shall prominently and legibly display at each side and at the rear of the wagon, in the English and Chinese languages, in letters and characters not less than 120 mm in height, the notice "NO SMOKING" and "HIGHLY FLAMMABLE GOODS". Similar "NO SMOKING" notice should also display inside cargo compartment. (Refer to Fig. 5)
- 9.2. The name and telephone number of the person to be contacted in the event of an emergency involving the cylinder wagon shall be prominently and legibly displayed in the English and Chinese languages, in letters and characters not less the 10mm in height, on each door of the cab of the wagon. (Refer to Fig. 6)

10. EQUIPMENT ATTACHED (TAIL-GATE LIFTS AND FIRE EXTINGUISHERS)

- 10.1. Tail-gate lift shall be provided for cylinder wagon which used to carry cylinder with 50 litres or more water capacity. In order to protect the compartment, impact absorber should be provided near the rear doors where the lift is installed. The lift should be secured properly if it is not in use and should not be treated as a compartment door. The energy supply to the lift should be able to isolate by the main battery switch. The tail-gate lift shall be of a fail safe design. Certificate by supplier to certify the compliance of design and standard of the lift should be available and to be submitted when require.
- 10.2. Fire extinguishers of 2 kg dry powder type shall be carried in such position as to be readily accessible outside the cab of the wagon and available for use. They should be placed and secured in fixed support. The topmost of the extinguisher should be located about 1.5m to 2.0m from ground level and not more than 300mm from the outer edge of the cab/ cargo compartment (Refer to Fig. 1 & 2). "Certificate of Fire Service Installations and Equipment" Form FS 251 should be available for inspection. Information includes the vehicle number, client name and address, type of installation and serial number should also be included in Form FS 251 to ensure the extinguishers are maintained at all times in good and efficient working order. Label with FSD registered contractor number, FS251 serial number,

maintenance and expire date should be affixed on the extinguishers. A sample of Form FS 251 and the label are given in Annex 3.

10.3. Spare tyre, repair tools and oil jack should be provided in the wagon.

10.4. All equipment should be in good and efficient order.

11. MATERIAL

11.1. The body, chassis, fuel tanks and all equipment of the vehicle shall be constructed of non-combustible material.

11.2. All combustible products should have at least 30 minutes fire-resistance rating.

11.3. Compartment floor should be covered with 3mm (1/8 inch) thick steel checker plate.

典型石油氣瓶車 (Typical Cylinder Wagon)



圖 1
Fig. 1



載貨間 (Cargo Compartment)

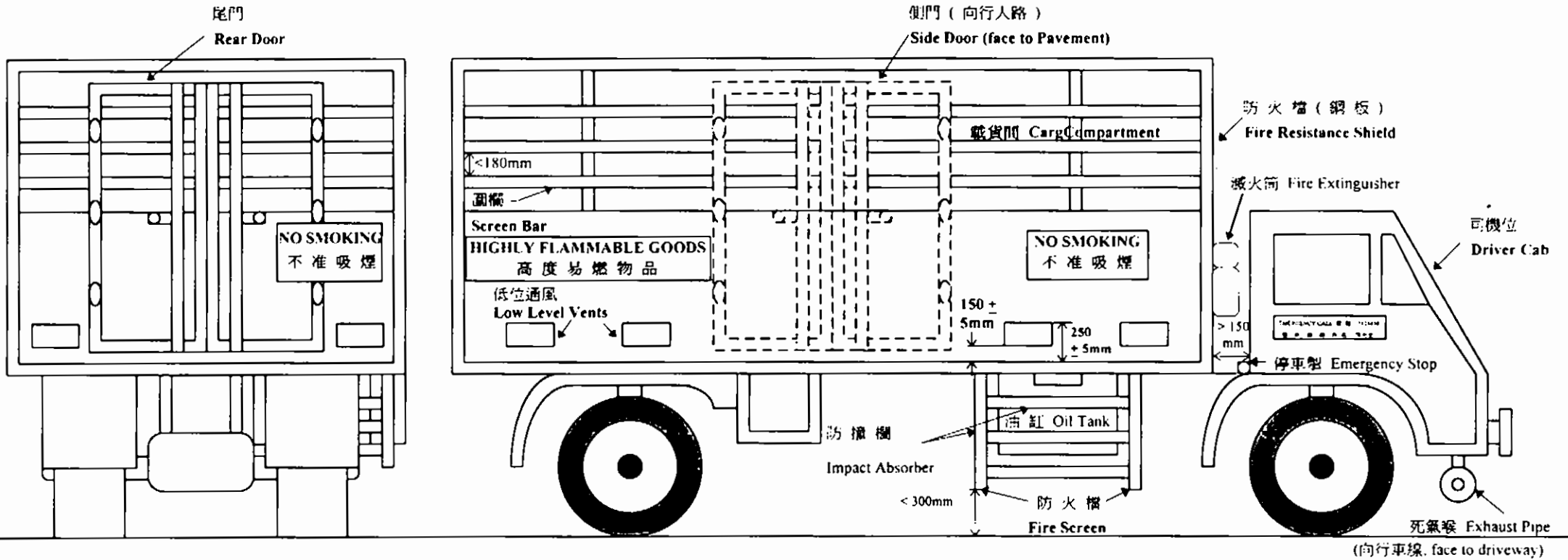
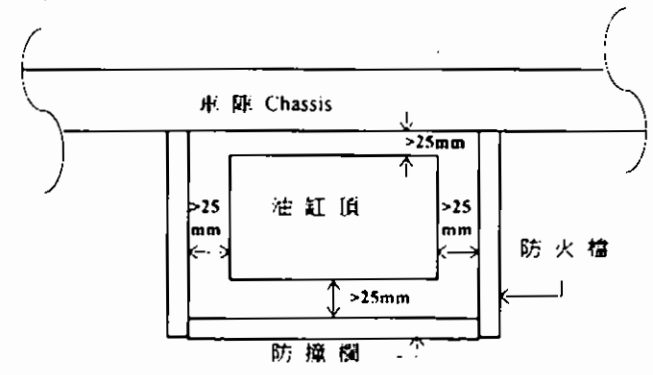

圖 1.1
(Fig. 1.1)

滅火筒乘載架
(FIRE EXTINGUISHER MOUNTING)

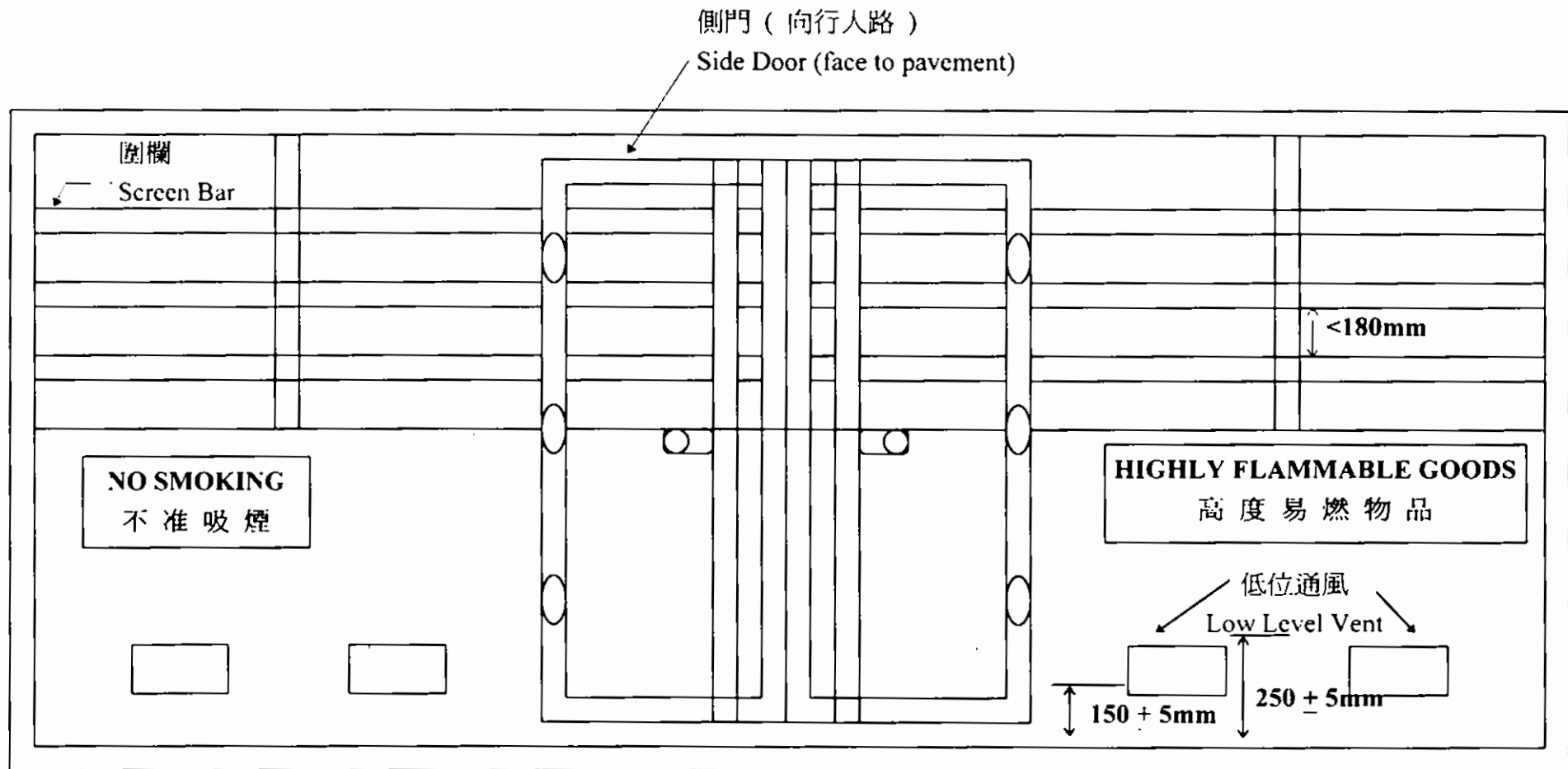
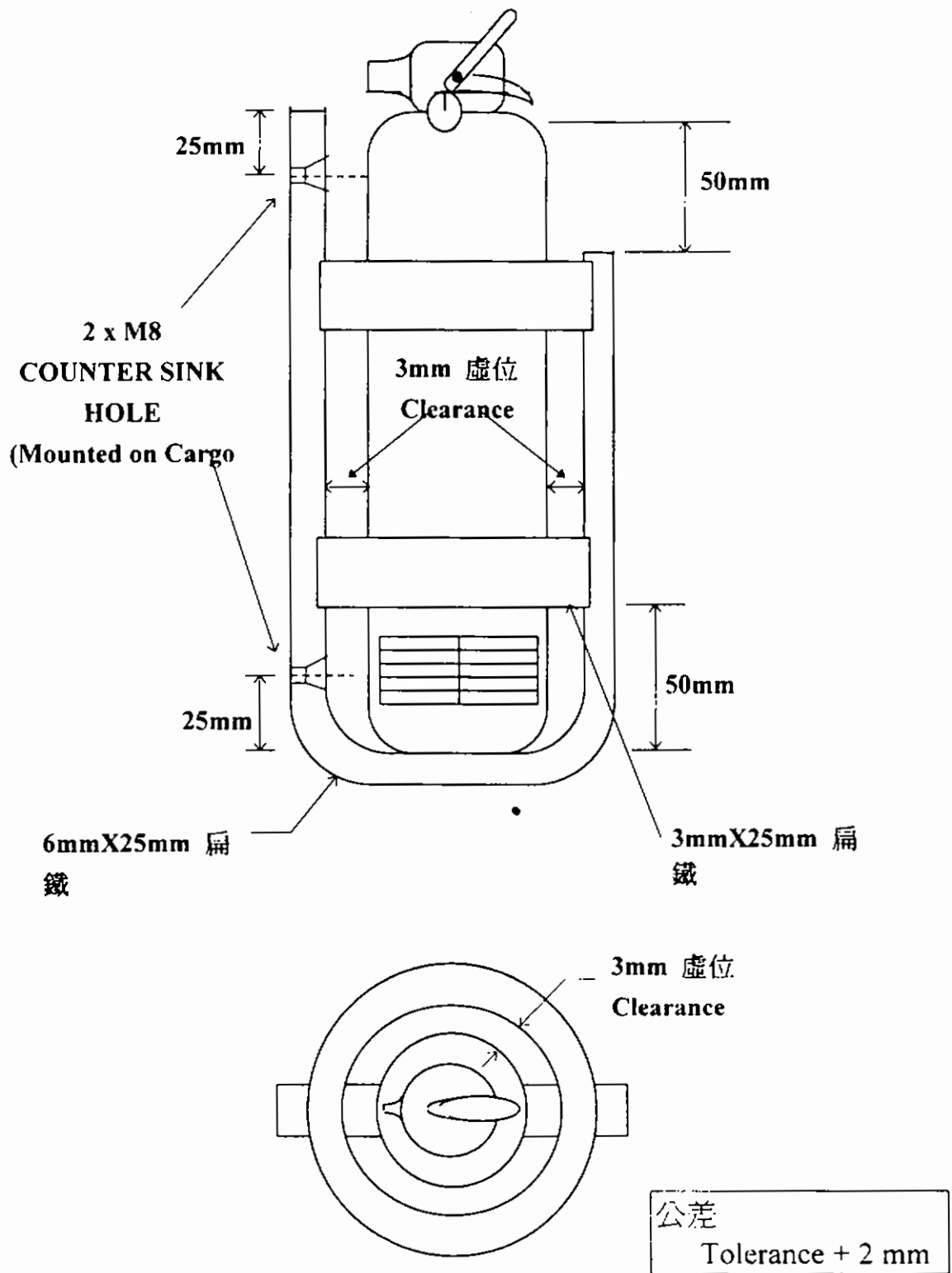

(圖 2)
Fig. 2

告示牌 (NOTICE)

1

緊急停車掣
拉
Emergency Engine Stop

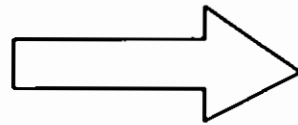

2

緊急停車掣
按
Emergency Engine Stop



圖 3
(Fig. 3)

電池總掣標籤

(BATTERY MAIN SWITCH LABEL)

1

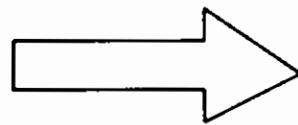
BATTERY MAIN SWITCH

電 池 總 掣

2

開
OPEN

關
CLOSE



圖 4
(Fig. 4)

告示牌 (NOTICE)

反光紅底白字

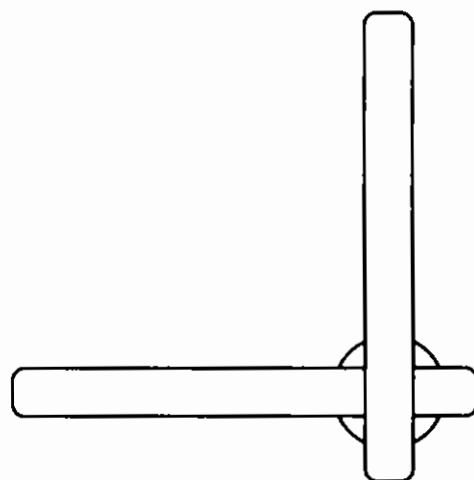

圖 5
(Fig. 5)

緊急聯絡告示

(Emergency Contact Notice)

EMERGENCY CONTACT NUMBER. : XXXX XXXX

緊 急 聯 絡 電 話

EMERGENCY CONTACT PERSON : XXX XXX XXX

緊 急 聯 絡 人 姓 名

圖 6

(Fig. 6)

Annex 1

Sample of VE 24 :

Vehicle Examination Report & Repair Order

SAMPLE

NEW KOWLOON BAY VEHICLE EXAMINATION CENTRE

新九龍灣驗車中心

8 TSUI HING STREET, KOWLOON BAY, KOWLOON 九龍灣翠興街八號

Telephone 電話: 2751-8862

Exam. Report No.
檢驗報告編號

XX

VEHICLE EXAMINATION REPORT AND REPAIR ORDER

車輛檢驗報告表及修理通知令

Vehicle Reg. Mark

車輛登記號碼

Class

類別

Chassis No. VIN

底盤/車輛識別號碼

Exam. Date

驗車日期

Make

廠名

Time

時間

Appointment No.

預約編號

Model

型號

Year of Manufacture

製造年份

Lane No.

驗車線號

ITEM	項目	RESULTS																				
		結果																				
1) VISUAL INSPECTION	表面檢驗																					
Unsatisfactory Items 不滿意項目 Skipped Items 無須檢驗項目																						
2) SIDE SLIP TEST	側滑測試																					
3) BRAKE TEST	制動測試																					
<table border="1"> <thead> <tr> <th>Brake Force (Kg)</th> <th>制動力</th> <th>Left Wheel 左輪</th> <th>Right Wheel 右輪</th> </tr> </thead> <tbody> <tr> <td>Front Axle</td> <td>前軸</td> <td></td> <td></td> </tr> <tr> <td>Rear Axle</td> <td>後軸</td> <td></td> <td></td> </tr> <tr> <td>Park Brake Axle</td> <td>泊車制動軸</td> <td></td> <td></td> </tr> <tr> <td>Total Axle Weight</td> <td>總軸重量</td> <td></td> <td></td> </tr> </tbody> </table>		Brake Force (Kg)	制動力	Left Wheel 左輪	Right Wheel 右輪	Front Axle	前軸			Rear Axle	後軸			Park Brake Axle	泊車制動軸			Total Axle Weight	總軸重量			
Brake Force (Kg)	制動力	Left Wheel 左輪	Right Wheel 右輪																			
Front Axle	前軸																					
Rear Axle	後軸																					
Park Brake Axle	泊車制動軸																					
Total Axle Weight	總軸重量																					
4) SPEEDOMETER TEST	車速錶測試																					
5) TAXIMETER TEST	的士計程器測試																					
6) HEAD LAMP TEST	車頭燈測試																					
7) EXHAUST SMOKE TEST	排煙測試																					
8) UNDER CARRIAGE INSPECTION	底盤檢驗																					
Unsatisfactory Items 不滿意項目 Skipped Items 無須檢驗項目																						
9) OVERALL EXAMINATION EVALUATION	整體測試評估																					

Upon passing the Overall Examination Evaluation, this report is required for vehicle relicensing and is only valid for this purpose within 4 months from the date of issue.

當整體測試評估合格後,車輛續牌時須出示此報告表,以更換車輛牌照。此報告表在簽發日起計四個月內有效。

The above vehicle having been examined in accordance with the Road Traffic Ordinance (Cap. 374 (Section 83 & 85) was found to have the defects listed above.

You are hereby required to rectify these defects and produce the vehicle for a further inspection within one month of the date given above.

本署根據香港法例第374章道路交通條例(第八十三及八十五條)之規定檢驗上述車輛後,發現有上述故障,請將有關故障修妥,然後在以上指定日期一個月內將該車交來覆驗。

For descriptions of items numbers to Visual Inspection & Under Carriage Inspection, please refer to overleaf for details.

附註車身表面及底盤檢驗的數字代號註解,請轉看後頁。

Asse Weights (t) 1. (

) 2. (

)

Lane Supervisor

驗車線主管

VE 24

Annex 2

Sample of TD 89 :

Motor Vehicle Certificate of Roadworthiness

TRANSPORT DEPARTMENT
運輸署
Motor Vehicle Certificate of Roadworthiness
檢驗汽車機械合格證書

Registration Mark 車輛號碼	Make 廠名	Model 類型
Chassis Number/V.I.N. 車身底盤號碼/車輛識辨號碼		
Class of Vehicle 車輛類別	New or Used 新車或舊車	Vehicle Examination Centre 驗車中心

The above vehicle having been examined under Section 78 of the Road Traffic Ordinance Cap. 374. I hereby certify that on the day of examination the requirements prescribed by the Road Traffic (Construction and Maintenance of Vehicles) Regulations, Cap. 374 have been complied with in relation to the said vehicle.

上述車輛經已依照香港法例第三百七十四章道路交通條例第七十八條接受檢驗。本人謹此證明此車輛於接受檢驗之日期已符合香港法例第三百七十四章道路交通(車輛構造及保養)規例所列出之條件。

Date

日期

.....

M.V.E. 驗車主任

For the purpose of licensing, this certificate must be presented within 4 months from the date of issue.

此證書須於簽發之日起計四個月內向本署提交作為領牌之用。

Serial No. :

編號

Annex 3

Sample of FS 251:

Certificate of Fire Service Installations & Equipment

SAMPLE

X XXXXXXXX

FSD Ref. :
消防處編號

FIRE SERVICE (INSTALLATIONS AND EQUIPMENT) REGULATIONS
消防(裝置及設備)規例
(Regulation 9(1))
(第九條(1)款)
CERTIFICATE OF FOR SERVICE INSTALLATIONS AND EQUIPMENT
消防裝置及設備證書

Name of Client :

顧客姓名

Name of Building 樓宇名稱

Address

地址

St. No. 門牌號數 Street/Road Name 街道名稱 Town Lot & No. 市地段及號碼

Flat/Room 室 Block 座 Floor 樓 District/Area 區分

PART 1

Item No. 項目編號	Type of Installation 裝置類型	Nature of Work Carried out 完成之工作內容	Comment on Condition 狀況評述

PART 2

Item No. 項目編號	Outstanding Defects 未修缺點	Comment on Defects 缺點評述

The works listed in Part 1 above were completed on 第一部所列的工程已於 ____ 年 ____ 月 ____ 日完成
..... and the above installations/equipment have 並經試驗, 證明性能良好, 符合消防處處長不時公布的最低限度
tested and found to be in efficient working order in accordance with the 消防裝置及設備守則的規格. 未修妥項目列於第一部.
Code of Practice for Minimum Fire Service Installations and Equipme
published from time to time by the Director of Fire Services. Exceptio
listed in Part 2.

Signature 簽名

Name 姓名

FSD/RC No. 消防處註冊號碼

Date 日期

for

(Firm's Name) (公司名稱)

F.S. 251

Registration Number 註冊編號	XXXXXXXX
Maintenance Date 保養日期	XX-XX-XX
Valid Until 有效日期至	XX-XX-XX
FS 251 Serial Number	XXXXXXXX
用戶稱或車牌號碼	XXXXXXXX

滅火筒標籤

Fire Extinguisher Label

香港特別行政區政府

氣體應用指南之十

石油氣瓶車的設計及建造
工作守則

內容

	<u>頁數</u>
1. 適用範圍	1
2. 車輛	1
3. 引擎	1
4. 油箱	1
5. 防火擋板	2
6. 載貨間	2
7. 緊急停車掣	3
8. 電力系統	3
9. 標記	4
10. 附加設備 (尾板起重機及滅火筒)	4
11. 材料	5
圖 1 - 典型石油氣瓶車建造方式	
圖 1.1 - 典型載貨間建造方式	
圖 2 - 典型滅火筒安裝方式	
圖 3 - 典型緊急停車掣告示	
圖 4 - 典型電池總掣告示	
圖 5 - 典型不准吸煙告示	
圖 6 - 典型緊急聯絡人姓名及電話號碼告示	
附件 1 - VE24 樣本 : 車輛檢驗報告及車輛修理令	
附件 2 - TD89 樣本 : 檢驗汽車機械合格證書	
附件 3 - FS 251 樣本 : 消防裝置及設備證書	

1. 適用範圍

- 1.1 本工作守則是根據氣體安全條例(第 51 章)第 9 條的規定而發出。本守則旨在說明石油氣瓶車須符合氣體安全(氣體供應)規例(第 51 章)附表 2 第 2 部詳載的條件。此外，本守則亦就有關要求的釋義提供實務指引。
- 1.2 由於本守則是有關規例附表 2 第 2 部的指引大綱，因此氣體標準事務處保留修訂本守則全部或部分內容的權利。

2. 車輛

- 2.1 有關車輛必須具備註明其最少在 9 個月內適宜在道路上行駛的「檢驗汽車機械合格證書」(表格 TD89)。至於換領石油氣瓶車許可證時，有關車輛必須在「車輛檢驗報告及車輛修理令」(表格 VE24)所訂明的「整體測試評估」項下取得合格。表格 TD89 及表格 VE24 的樣本載於附件 1 及 2。
- 2.2 石油氣瓶車及其裝備須保持良好及高效率的性能。

3. 引擎

- 3.1 引擎須為壓燃式(例如柴油引擎)，並須符合道路交通(車輛構造及保養)規例(第 374 章附屬法例)所載定義。
- 3.2 引擎須結構完善，並須安裝在適當位置(例如：在駕駛室之下)或受到適當保護，以免對石油氣瓶車運載的石油氣瓶構成危險。
- 3.3 引擎的進氣系統須可防止引擎逆火以致火焰傳播。宜採用金屬鮮風隔代替紙風隔。
- 3.4 必須將整個排氣系統安裝在防火擋板之前，並安排將廢氣排放至不影響車輛載貨間及油箱的一面。
- 3.5 排氣系統須裝防火花障。
- 3.6 排氣喉的末端不得超越車身及防火擋板。

4. 油箱

- 4.1 油箱須為雙層包箱。

- 4.2 油箱的注油孔蓋或外層包箱須配鎖。
- 4.3 外層包箱底部四角須有 10 毫米(3/8 吋)的孔口，以便油箱發生漏油時，燃油亦祇會流到地上。
- 4.4 油箱須與瓶車駕駛室分隔，並在油箱的頂部、左方、右方及後方裝設防火擋板，以保護油箱免被火燒。油箱尾後的木製底盤不可用作防火擋板。如使用金屬底盤作防火擋板，橫槓上的孔口須予以密封。
- 4.5 油箱必須配置鋼架，以保護油箱免受碰撞。鋼架必須結構堅固，並與油箱分隔最少 25 毫米(1 吋)。(見圖 1)

5. 防火擋板

- 5.1 必須提供防火擋板，以便將載貨間與駕駛室的內部、油箱、發電機、引擎、電池、開關裝置、保險絲、空氣調節系統及排氣系統予以分隔。防火擋板須為具備最少 30 分鐘耐火能力的鋼板(3 毫米厚)。
- 5.2 用以分隔載貨間與駕駛室的防火擋板，必須最少與駕駛室距離 150 毫米(6 吋)，而其上端必須超越載貨間頂點的高度，下端則不得離地超過 300 毫米(12 吋)。除裝設玻璃窗口及孔口部分外，擋板必須整塊連貫，沒有任何破裂。
- 5.3 防火擋板如設有玻璃窗口，全部窗口須選用嵌絲玻璃(6 毫米或 1/4 吋厚)，並裝於固定金屬框內，且不能開啓。
- 5.4 防火擋板上供喉管(引擎軸承，氣動剎車喉管等)通過的孔口，要盡量修飾到最小，以防止可燃蒸汽通過。孔口的縫隙須用適當的填縫料密封。

6. 載貨間

- 6.1 載貨間須用金屬板及金屬架等不可燃材料建造。
- 6.2 如使用木材建造載貨間，木材須以金屬板包裹。木材建造載貨間只適用於續牌的石油氣瓶車。
- 6.3 載貨間的地台必須結構堅固，地台須以金屬柱支承，並鋪上 3 毫米(1/8 吋)厚的網紋鋼板。
- 6.4 載貨間須有一個用耐火材料造成的固定車頂。

- 6.5 載貨間須通風良好，並須提供高低通風孔。圍欄上的空隙闊度須少於 180 毫米。
- 6.6 低通風孔須是載貨間地台面積的 1/50，並須沿載貨間邊旁平均地分布。載貨間地台與通風孔的底部及最頂部的距離須分別少於 150 毫米±5 毫米及 250 毫米±5 毫米。(例子：沿載貨間左邊、右邊及後邊如共設有 8 至 10 個 100 毫米高 x 200 毫米闊的孔口，可視作足夠，但仍須視乎載貨間的地台面積而定。)
- 6.7 載貨間須能上鎖。
- 6.8 保險門須操作良好，以及並無損壞。
- 6.9 載貨間的金屬面須有防銹保護(防銹油漆)。
- 6.10 載貨間內不得建造獨立的儲存空間。

7. 緊急停車掣

- 7.1 石油氣瓶車須設有用以截斷瓶車燃油供應及關閉該車引擎的緊急停車掣。在驗車時，司機須示範緊急停車掣的操作。
- 7.2 緊急停車掣須設於駕駛室外面容易到達的位置。
- 7.3 必須以顯著及清楚的方式展示中、英文「緊急停車掣」標記，以說明緊急停車掣的位置和操作方法。(見圖 3)。
- 7.4 安裝方式有機械式、連桿式和電控式。機械式須採用有金屬套的「T」型手柄，電控式則須採用防火及防水的開關盒(220 伏特、15 安培)。所有緊急停車掣均須為紅色，以方便辨認。

8. 電力系統

- 8.1 石油氣瓶車所有電氣裝置的構造及安裝，須足以預防短路及火警發生。
- 8.2 所有安裝在石油氣瓶車可能積聚石油氣蒸汽的密封部分(例如載貨間)的電氣裝置，均須設計及建造成適合在 BS EN 60079-10: 1996 所界定的第 1 區範圍內使用。
- 8.3 電路電壓不得超過 24 伏特(直流)。
- 8.4 電池須穩妥地安裝在防火擋板之前，但不得安裝在駕駛室內。

- 電池須加上蓋，以盡量減低出現短路的機會。
- 8.5 電池總線的橫截面面積最少要有 35 平方毫米，而正極須連接到電池總掣上，負極則須接地。
- 8.6 電池總掣須安裝在駕駛室容易到達的位置，而該位置須清楚標明。(見圖 4)。最好是安裝在錶板左上方。此掣須能切斷所有電氣裝置，包括電燈、揚聲器、起動器和尾板起重機等的電源。在驗車時，司機須示範此總掣的操作。
- 8.7 所有電氣裝置須操作性能良好，不必要和非固定的電氣裝置不得裝設，例如流動無線電話、電熱點煙器等。
- 8.8 所有電線接口不得外露，並須絕緣良好。裝在防火擋板後的電線要套上金屬線管。

9. 標記

- 9.1 石油氣瓶車須在其兩側及車尾顯著和清楚地展示中、英文「不准吸煙」及「高度易燃物品」告示，告示上中文字和英文字母的高度不得少於 120 毫米。載貨間內亦須展示類似的「不准吸煙」告示。(見圖 5)。
- 9.2 須將石油氣瓶車遇有緊急情況時可聯絡的人的姓名及電話號碼，以中、英文顯著及清楚地展示在瓶車駕駛室的每扇門上，所用中文字和英文字母的高度不得少於 10 毫米。(見圖 6)。

10. 附加設備(尾板起重機及滅火筒)

- 10.1 石油氣瓶車如用作運載容水量 50 升或以上的石油氣瓶，須裝設尾板起重機。為保護載貨間，應在裝設起重機的尾門附近安裝避震防撞膠。尾板起重機在不使用時應固定在適當位置，不可當作載貨間的尾門。電池總掣須能切斷尾板起重機的電源。尾板起重機須採用故障保險式設計。如有需要，應提交由供應商發出的證書，以證明尾板起重機的設計和標準符合規定。
- 10.2 石油氣瓶車須在駕駛室外容易到達及隨時可取用的位置，放置 2 千克乾粉式滅火筒。滅火筒應穩妥地安放在固定支架上。滅火筒頂部須離地約 1.5 米至 2.0 米，並距離駕駛室/載貨間外緣不多於 300 毫米(見圖 1 及圖 2)。瓶車須備有「消防裝置及設備證書」表格 FS 251，以供檢查。表格 FS 251 內應載有瓶車號碼、客戶姓名及地址、裝置類別、編號等資料，以確保滅火筒經常保持良好及高效率的性能。滅火筒須貼上載有消防處註冊承辦商號碼、表格 FS 251 編號、保養和屆滿日期等資料的標籤。表格 FS

251 和標籤的樣本載於附件 3。

10.3 石油氣瓶車上須備有後備輪胎、修理工具和油壓千斤頂。

10.4 所有設備均須保持良好及高效率的性能。

11. 材料

11.1 車身、底盤、油缸和車上所有設備均須以不可燃物料製造。

11.2 所有可燃物料最少須有 30 分鐘的耐火能力。

11.3 載貨間地台應鋪設 3 毫米(1/8 吋)厚的網紋鋼。

典型石油氣瓶車 (Typical Cylinder Wagon)



圖 1
Fig. 1



載貨間 (Cargo Compartment)

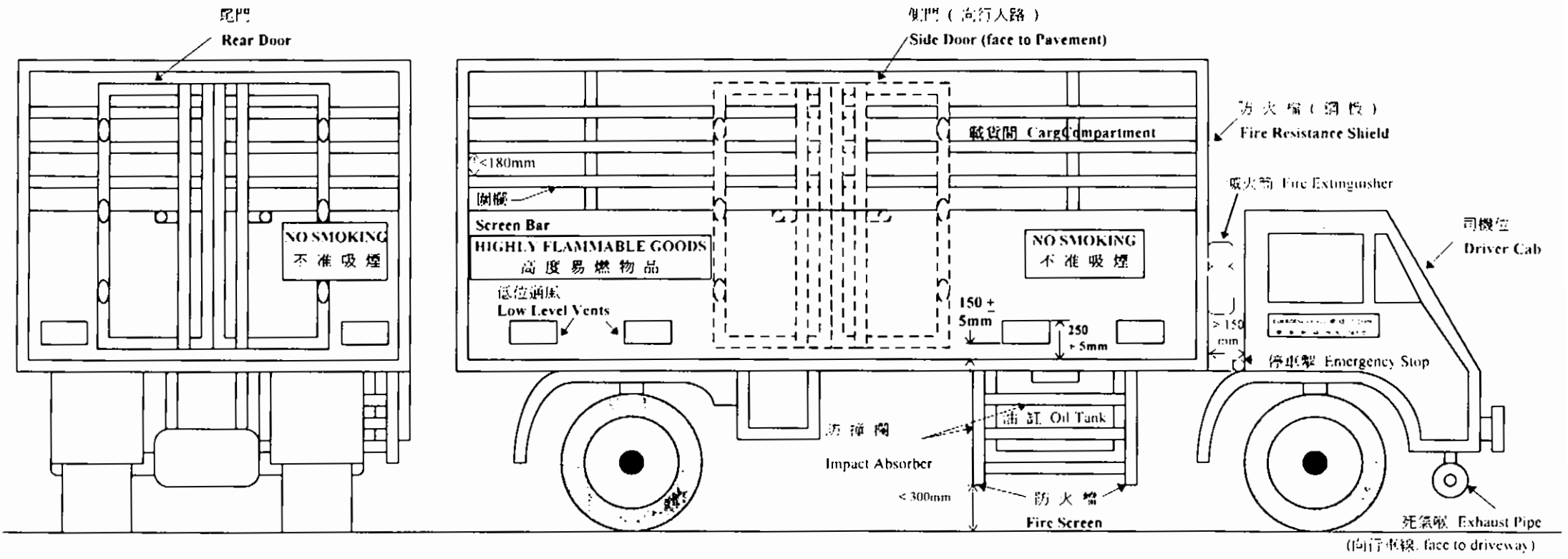
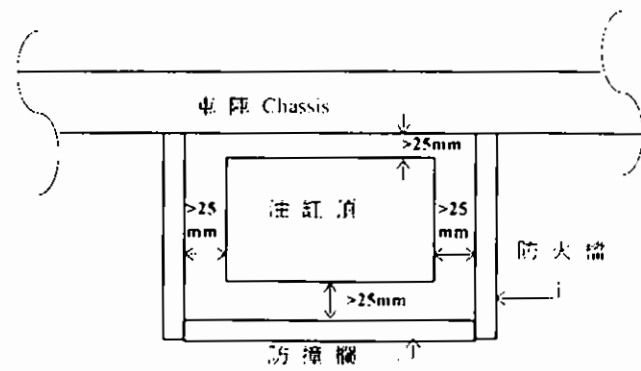

圖 1.1
(Fig. 1.1)

滅火筒乘載架 (FIRE EXTINGUISHER MOUNTING)

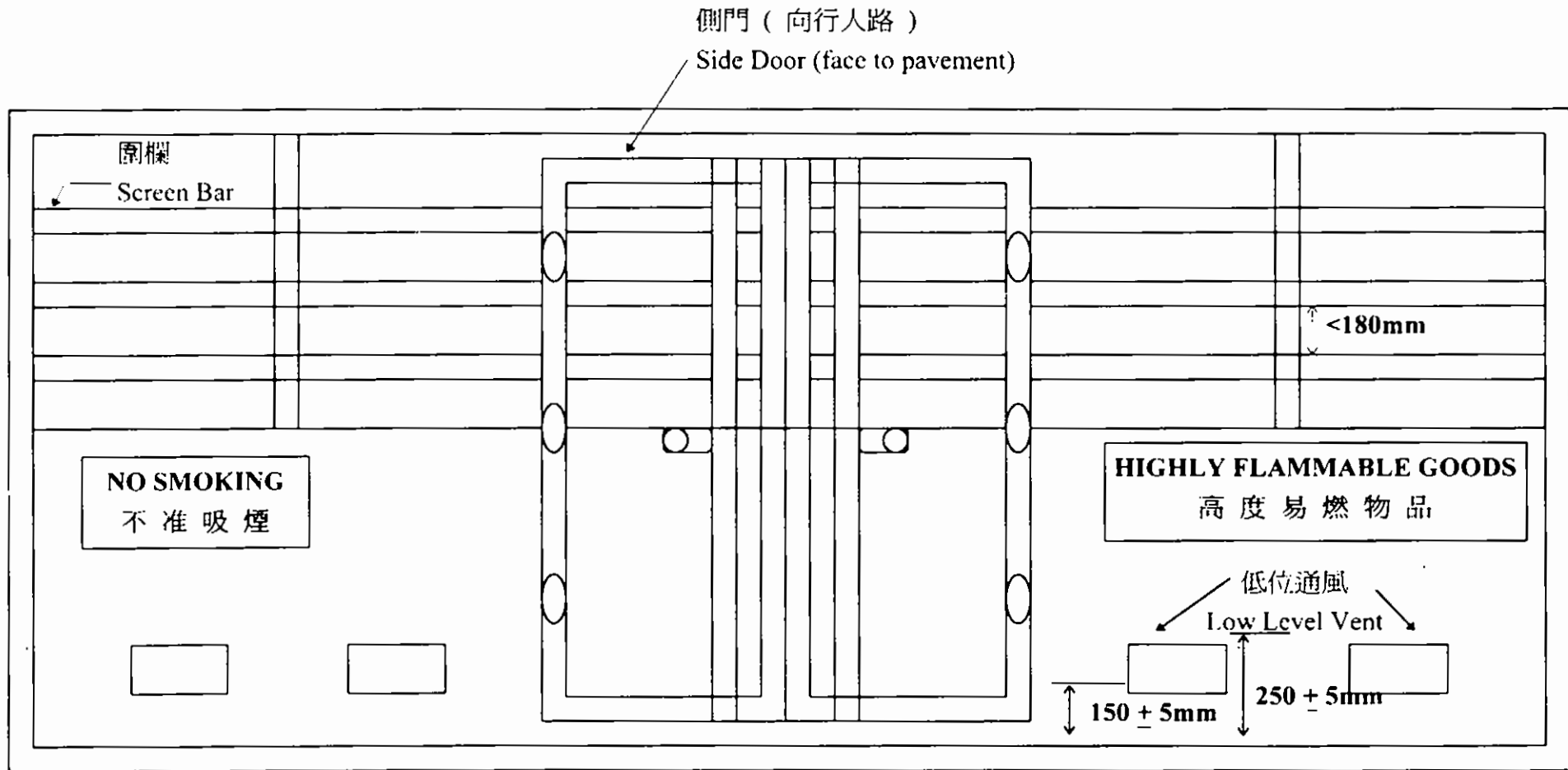
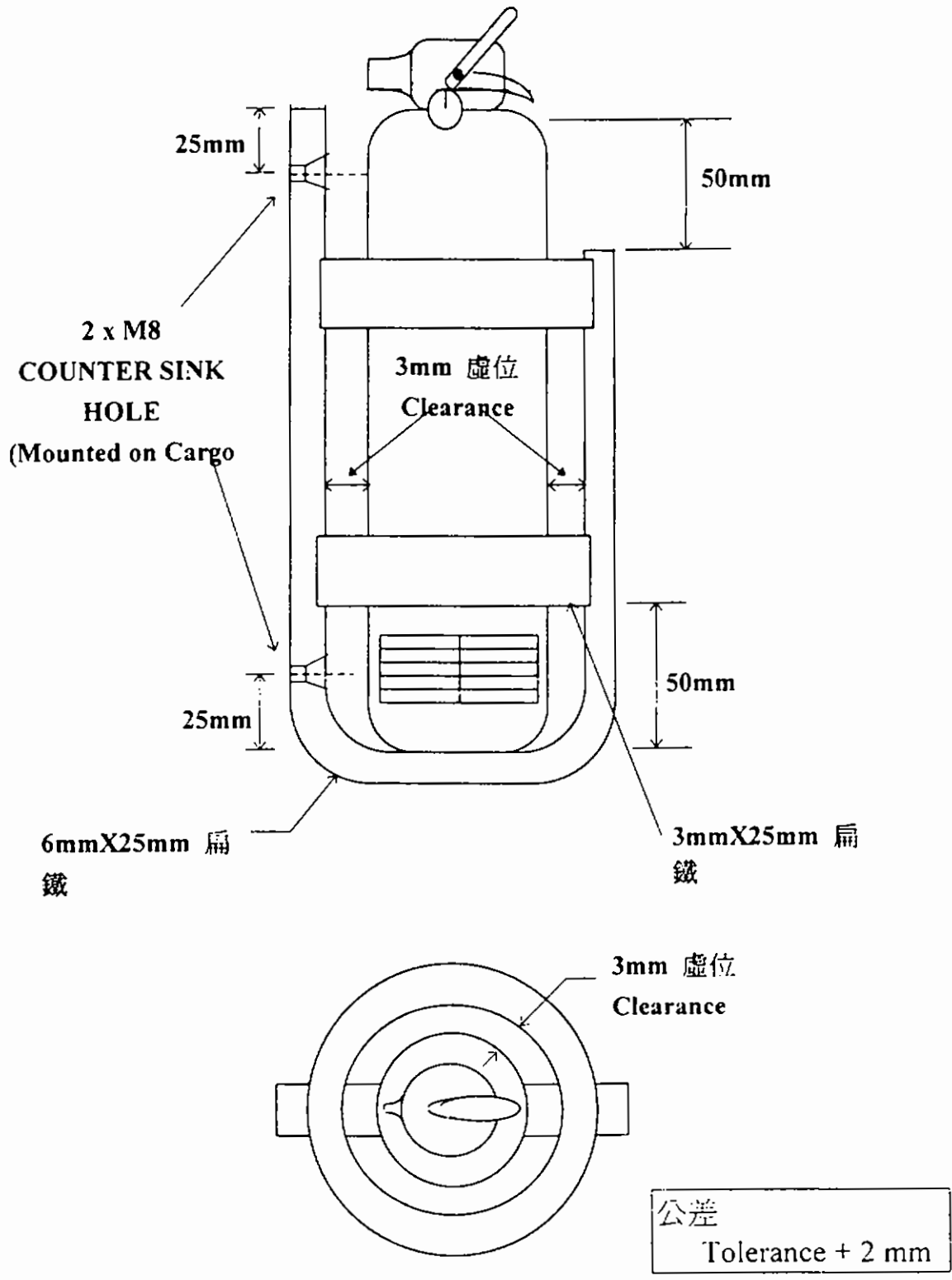

(圖 2)
Fig. 2

告示牌 (NOTICE)

1

緊急停車掣
拉
Emergency Engine Stop

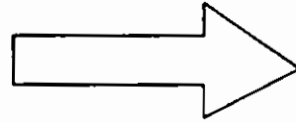

2

緊急停車掣
按
Emergency Engine Stop



圖 3
(Fig. 3)

電池總掣標籤

(BATTERY MAIN SWITCH LABEL)

1

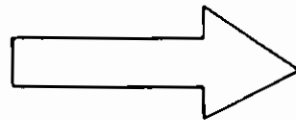
BATTERY MAIN SWITCH

電 池 總 掣

2

開
OPEN

關
CLOSE



圖 4

(Fig. 4)

告示牌 (NOTICE)

反光紅底白字

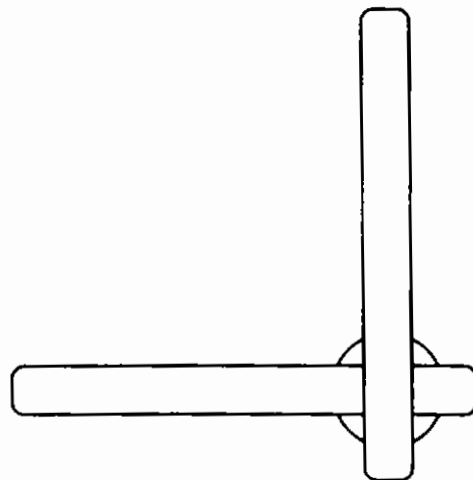

圖 5
(Fig. 5)

緊急聯絡告示

(Emergency Contact Notice)

EMERGENCY CONTACT NUMBER. : XXXX XXXX

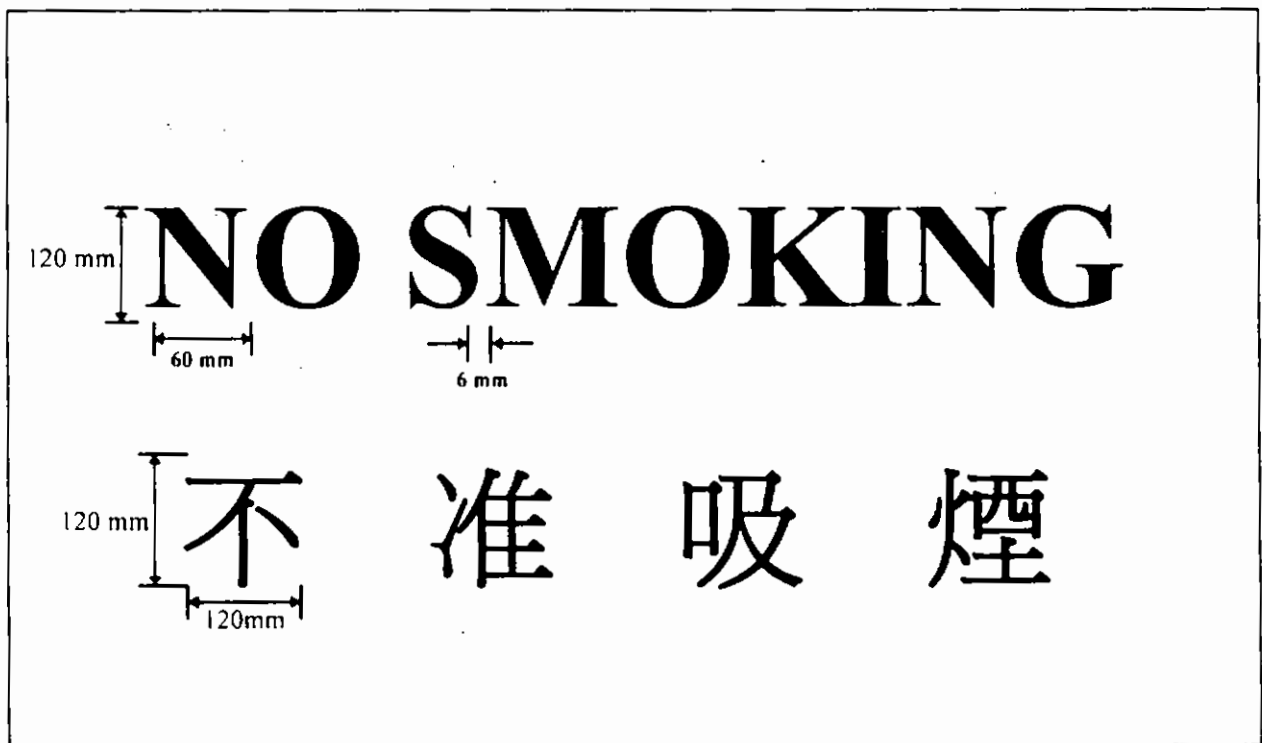
緊急聯絡電話

EMERGENCY CONTACT PERSON : XXX XXX XXX

緊急聯絡人姓名

圖 6

(Fig. 6)

附件 1

VE 24 樣本：

車輛檢驗報告及車輛修理令

SAMPLE

NEW KOWLOON BAY VEHICLE EXAMINATION CENTRE

新九龍灣驗車中心

8 TSUI HING STREET, KOWLOON BAY, KOWLOON 九龍灣翠興街八號

Telephone 電話: 2751-8862

Exam. Report No.
檢驗報告編號

XX

VEHICLE EXAMINATION REPORT AND REPAIR ORDER

車輛檢驗報告表及修理通知令

Vehicle Reg. Mark

車輛登記號碼

Class

類別

Chassis No VIN

底盤/車輛識別號碼

Exam. Date

驗車日期

Make

廠名

Time

時間

Appointment No.

預約編號

Model

型號

Year of Manufacture

製造年份

Lane No

驗車線號

ITEM	項目	RESULTS																				
		結果																				
1) VISUAL INSPECTION	表面檢驗																					
Unsatisfactory Items 不滿意項目 Skipped Items 無須檢驗項目																						
2) SIDE SLIP TEST	側滑測試																					
3) BRAKE TEST	制動測試																					
<table border="1"> <thead> <tr> <th>Brake Force (Kg)</th> <th>制動力</th> <th>Left Wheel 左輪</th> <th>Right Wheel 右輪</th> </tr> </thead> <tbody> <tr> <td>Front Axle</td> <td>前軸</td> <td></td> <td></td> </tr> <tr> <td>Rear Axle</td> <td>後軸</td> <td></td> <td></td> </tr> <tr> <td>Park Brake Axle</td> <td>泊車制動軸</td> <td></td> <td></td> </tr> <tr> <td>Total Axle Weight</td> <td>總軸重量</td> <td></td> <td></td> </tr> </tbody> </table>		Brake Force (Kg)	制動力	Left Wheel 左輪	Right Wheel 右輪	Front Axle	前軸			Rear Axle	後軸			Park Brake Axle	泊車制動軸			Total Axle Weight	總軸重量			
Brake Force (Kg)	制動力	Left Wheel 左輪	Right Wheel 右輪																			
Front Axle	前軸																					
Rear Axle	後軸																					
Park Brake Axle	泊車制動軸																					
Total Axle Weight	總軸重量																					
4) SPEEDOMETER TEST	車速錶測試																					
5) TAXIMETER TEST	的士計程器測試																					
6) HEAD LAMP TEST	車頭燈測試																					
7) EXHAUST SMOKE TEST	排煙測試																					
8) UNDER CARRIAGE INSPECTION	底盤檢驗																					
Unsatisfactory Items 不滿意項目 Skipped Items 無須檢驗項目																						
9) OVERALL EXAMINATION EVALUATION	整體測試評估																					

Upon passing the Overall Examination Evaluation, this report is required for vehicle relicensing and is only valid for this purpose within 4 months from the date of issue.

當整體測試評估合格後,車輛續牌時須出示此報告表,以更換車輛牌照,此報告表在簽發日起計四個月內有效。

The above vehicle having been examined in accordance with the Road Traffic Ordinance Cap. 374 (Section 83 & 85) was found to have the defects listed above.

You are hereby required to rectify these defects and produce the vehicle for a further inspection within one month of the date given above.

本署根據香港法例第374章(道路交通條例)第八十三及八十五條之規定,檢驗上述車輛後,發現有上述故障,請諸台鑒將故障修妥,然後在以上指定日期一個月內將該車交來覆驗。

For descriptions of items numbers to Visual Inspection & Under Carriage Inspection, please refer to overleaf for details.

附註車身表面及底盤檢驗的數字代號註解,請轉看後頁。

Axle Weights (t) 1. (

) 2. (

)

VE 24

Lane Supervisor

驗車線主管

附件 2

TD 89 樣本：

檢驗汽車機械合格證書

SAMPLE

TRANSPORT DEPARTMENT
運 輸 署
Motor Vehicle Certificate of Roadworthiness
檢 驗 汽 車 機 械 合 格 證 書

Registration Mark 車輛號碼	Make 廠名	Model 類型
Chassis Number/V.I.N. 車身底盤號碼/車輛識辨號碼		
Class of Vehicle 車輛類別	New or Used 新車或舊車	Vehicle Examination Centre 驗車中心

The above vehicle having been examined under Section 78 of the Road Traffic Ordinance Cap. 374. I hereby certify that on the day of examination the requirements prescribed by the Road Traffic (Construction and Maintenance of Vehicles) Regulations, Cap. 374 have been complied with in relation to the said vehicle.

上述車輛經已依照香港法例第三百七十四章道路交通條例第七十八條接受檢驗。本人謹此證明此車輛於接受檢驗之日期已符合香港法例第三百七十四章道路交通(車輛構造及保養)規例所列出之條件。

Date

日期

.....

M.V.E. 驗車主任

For the purpose of licensing, this certificate must be presented within 4 months from the date of issue.

此證書須於簽發之日起計四個月內向本署提交作為領牌之用。

Serial No. :

編號

附件 3

FS 251 樣本:

消防裝置及設備證書

SAMPLE

X XXXXXXXX

FSD Ref. :
消防處編號

FIRE SERVICE (INSTALLATIONS AND EQUIPMENT) REGULATIONS
消防(裝置及設備)規例
(Regulation 9(1))
(第九條(1)款)
CERTIFICATE OF FOR SERVICE INSTALLATIONS AND EQUIPMENT
消防裝置及設備證書

Name of Client :

顧客姓名

Address Name of Building 樓宇名稱

地址

St. No. 門牌號數 Street/Road Name 街道名稱 Town Lot & No. 市地段及號碼

Flat/Room 室 Block 座 Floor 樓 District/Area 區分

PART 1

Item No. 項目編號	Type of Installation 裝置類型	Nature of Work Carried out 完成之工作內容	Comment on Condition 狀況評述

PART 2

Item No. 項目編號	Outstanding Defects 未修缺點	Comment on Defects 缺點評述

The works listed in Part 1 above were completed on 第一部所列的工程已於 年
月 日完成
..... and the above installations/equipment have 並經試驗, 證明性能良好, 符合消防處處長不時公布的最低限度
tested and found to be in efficient working order in accordance with th 消防裝置及設備守則的規格. 未修妥項目列於第一部.
Code of Practice for Minimum Fire Service Installations and Equipme
published from time to time by the Director of Fire Services. Exceptio
listed in Part 2.

Signature 簽名

Name 姓名

FSD/RC No. 消防處註冊號碼

Date 日期

for

(Firm's Name) (公司名稱)

F.S. 251

Registration Number 註冊編號	XXXXXXXX
Maintenance Date 保養日期	XX-XX-XX
Valid Until 有效日期至	XX-XX-XX
FS 251 Serial Number	XXXXXXXX
用戶稱或車牌號碼	XXXXXXXX

滅火筒標籤
Fire Extinguisher Label